

## Introduction

I found these books to be very helpful for specific problems and troubles as found and documented by the TV manufacturers themselves during the 50's. I decided they would be helpful to others in the hobby of fixing up and obsessing over old TV's like myself. Please let me know if you see any issues with the scans or need clarification on something that is not clear/visible in a scan.

From the general preface:

*This is a series of volumes which deal with specific TV receiver troubles and their cures. These trouble cures are the TV manufacturers' answers to some of the problems that may arise in their particular receivers.*

*After a certain model or chassis has been in the field for a while, certain troubles may occur which are peculiar to that receiver. In an effort to maintain his own good reputation, the manufacturer is interested in keeping his receiver in tip-top working order. Therefore, his service or engineering department evolves a cure for the particular trouble.*

*The question may be asked, "Why doesn't the manufacturer incorporate the cure into future production runs on his own receiver? The answer is that he frequently does. However, it is certainly not possible, with such a complex device as a TV receiver, to hold off on production until every single "bug" has been removed. The fact remains that many receivers are in the field and do develop certain peculiarities of operation for which the manufacturer has a definite tried-and-tested cure. Many of these cures will be found in these volumes.*

*In addition, the development of new ideas and circuitry is unending. These new ideas are conceived by TV receiver manufacturers and many of the circuits can be incorporated into receivers already in the field. Such changes will improve the operation of the receiver, especially under unusual or difficult operating conditions. What is more, in areas of high humidity, in fringe areas, in strong-signal areas, etc., certain troubles are apt to occur. Many of the manufacturers' trouble cures given in this volume will alleviate these troubles when properly applied to the receiver in question.*

*You will note that these volumes contain valuable information relating to trouble cures and circuit changes which will actually improve the operation of the TV receiver. You will not be given generalized instructions to "check this capacitor" or "check that tube" if a certain trouble appears. Instead, you will be given exact directions as to the specific operation to be performed in affecting the cure. In all cases where components are identified, the manufacturers own circuit symbol is used. This makes it easy to utilize the information given in these pages along with Rider Manuals and Tek-File. A complete index in which trouble cures are listed by brand and chassis or model number appears at the end of this volume.*

## Volumes

There are seven volumes available (that I know about). Volumes 1-5 cover most sets and were published between 1953 and 1954. Volumes 6 and 7 cover newer sets in 1954 and 1955 and include some updates for brands covers in earlier volumes.

Volume 1			
Cat. No. 143-1, 115 Pages, Published January, 1953			
Admiral	Air King	Andrea	Arvin
Belmont-Raytheon	Bendix	Calbest	Caphart-Farnsworth
CBS-Columbia	Certified	Crosley	DuMont

<b>Volume 2</b>			
Cat. No. 143-2, 117 Pages, Published February, 1953			
Emerson	Fada	Firestone	Freed
Gamble-Skogmo	General Electric	Hallicrafters	Hoffman
Industrial TV	International TV	Jackson	
<b>Volume 3</b>			
Cat. No. 143-3, 119 Pages, Published April, 1953			
Kaye-Halbert	Kent	Magnavox	Majestic
Meck	Mercury	Midwest	Montgomery Ward
Motorola	Muntz	National	North American Philips
Olympic	Pacific Mercury	Packard-Bell	Philco

<b>Volume 4</b>			
Cat. No. 143-4, 120 Pages, Published July, 1953			
Philharmonic	Pilot	Radio and Television (Brunswick)	RCA Victor
Remington (Rembrandt)	Scott	Sears Roebuck	Sentinel
Setchell Carlson	Shaw TV		

<b>Volume 5</b>			
Cat. No. 143-5, 119 Pages, Published March, 1954			
Sparton	Stewart-Warner	Stromberg-Carlson	Sylvania
Tele King	Trad TV	Transvision	Trav-ler
Wells-Gardner	Western Auto (Truetone)	Westinghouse	Zenith

<b>Volume 6</b>			
Cat. No. 143-6, 120 Pages, Published November, 1954			
Admiral	Aimcee (AMC)	Arvin	Bendix
Cadillac TV	Capehart	CBS-Columbia	Conrac
Crosley	DuMont	Emerson	Firestone

<b>Volume 7</b>			
Cat. No. 143-7, 112 Pages, Published June, 1955			
General Electric	Hallicrafters	Hoffman	Jackson
Kaye-Halbert	Magnavox	Majestic	Mars TV
Mattison TV	Meck	Montgomery Ward	Motorola
Muntz	Pacific Mercury	Packard-Bell	Philco
Philharmonic	Radio Craftsmen	Raytheon	

# TV

## MANUFACTURERS' RECEIVER TROUBLE CURES

### **VOLUME 1**

(Cat. No. 143)

**Admiral  
Air King  
Andrea  
Arvin  
Belmont-Raytheon  
Bendix  
Calbest  
Capehart-Farnsworth  
CBS-Columbia  
Certified  
Crosley  
DuMont**

*A RIDER Publication*

\$1.80

*Copyright 1953 by*

**JOHN F. RIDER PUBLISHER, INC.**

*All rights reserved including that of translation into  
the Scandinavian and other foreign languages.*

**Printed in the United States of America**

## PREFACE

This is the first in a series of volumes which deals with specific tv receiver troubles and their cures. These trouble cures are the tv manufacturers' answers to some of the problems that may arise in their particular receivers.

After a certain model or chassis has been in the field for a while, certain troubles may occur which are peculiar to that receiver. In an effort to maintain his own good reputation, the manufacturer is interested in keeping his receiver in tip-top working order. Therefore, his service or engineering department evolves a cure for the particular trouble.

The question may be asked, "Why doesn't the manufacturer incorporate the cure into future production runs of his own receiver? The answer is that he frequently does. However, it is certainly not possible, with such a complex device as a tv receiver, to hold off on production until every single "bug" has been removed. The fact remains that many receivers are in the field and do develop certain peculiarities of operation for which the manufacturer has a definite tried-and-tested cure. Many of these cures will be found in this volume.

In addition, the development of new ideas and circuitry is unending. These new ideas are conceived by tv receiver manufacturers and many of the circuits can be incorporated into receivers already in the field. Such changes will improve the operation of the receiver, especially under unusual or difficult operating conditions. What is more, in areas of high humidity, in fringe areas, in strong-signal areas, etc., certain troubles are apt to occur. Many of the manufacturers' trouble cures given in this volume will alleviate these troubles when properly applied to the receiver in question.

You will note that this volume contains valuable information relating to trouble cures and circuit changes which will actually improve the operation of the tv receiver. You will not be given generalized instructions to "check this capacitor" or "check that tube" if a certain trouble appears. Instead, you will be given exact directions as to the specific operation to be performed in affecting the cure. In all cases where components are identified, the manufacturer's own circuit symbol is used. This makes it easy to utilize the information given in these pages along with *Rider Manuals* and *Tek-File*. A complete index in which trouble cures are listed by brand and chassis or model number appears at the end of this volume.

The editor wishes to acknowledge the cooperation of the following tv receiver manufacturers who furnished the information contained in this volume:

ADMIRAL

AIR KING

ANDREA

ARVIN

BELMONT-RAYTHEON

BENDIX

CALBEST

CAPEHART-FARNSWORTH

CBS-COLUMBIA

CERTIFIED

CROSLEY

DUMONT

*January, 1953*

Milton S. Snitzer

# CONTENTS

MANUFACTURER	CHASSIS OR MODEL	PAGE
<b>ADMIRAL</b>		<b>1-23</b>
	20A1	1-2
	20B1	1-3
	20T1	1, 3-8
	20V1	1, 3-8
	20X1	1, 8-10
	20Y1	1, 8-10
	20Z1	1, 8-10
	21-series chassis	11
	21A1	1-3
	21B1	1, 3-6, 10-14
	21C1	3-6, 10-14
	21D1	3-6, 11-12, 16
	21E1	3-6, 11-12
	21F1	3, 14
	21G1	3, 4
	21H1	3-6, 11-12
	21J1	3-6, 11-12, 16
	21K1	3
	21L1	3
	21P1	3
	21Q1	3
	24D1	1, 7, 16-21
	24E1	1, 7, 16-21
	24F1	1, 7, 16-21
	24G1	1, 7, 16-21
	24H1	1, 7, 16-21
	30A1	1, 22-23
	30B1	1, 22-23
	30C1	1, 22-23
	30D1	1, 22-23
	Chassis with metal picture tubes	23

MANUFACTURER	CHASSIS OR MODEL	PAGE
<b>AIR KING</b>		<b>24-26</b>
	700-series	24
	700-10 or later	24
	700-10	25-26
	700-20	25-26
	700-30	25-26
	700-40	25-26
	700-50	25-26
	700-90	26
	700-91	26
	700-92	26
	700-93	26
	700-94	26
	700-95	26
	700-96	26
	All 16-inch chassis	26
<b>ANDREA</b>		<b>27-28</b>
	VL-series chassis	27
	VL-12	27
	VL-16	27-28
	VL-19	27
	All chassis	27
<b>ARVIN</b>		<b>29-38</b>
	TE-272	29
	TE-272-1	29-30
	TE-272-2	29-30
	TE-276	29-30
	TE-286	30-31
	TE-289-2	31
	TE-289-3	31-33
	TE-290	32-34
	TE-290-2	31-32, 34
	TE-290-3	31-32
	TE-300	34-35
	TE-302	34
	TE-302-2	35
	TE-302-3	36
	TE-302-4	36
	TE-302-5	36



MANUFACTURER	CHASSIS OR MODEL	PAGE
<b>ARVIN</b>		<b>29-38</b>
	TE-315	34-35
	TE-315-1	35
	TE-315-2	36
	TE-315-3	36
	TE-315-4	36
	TE-389	36-37
	12½-inch chassis	37-38
<b>BELMONT-RAYTHEON</b>		<b>38-45</b>
	7DX22-B	38-39
	10AXF43	39-41
	10DX21	39-41
	10DX22	39-41
	10DX24	39-41
	14AX21	41-42
	16AY28	42-43
	16AY211	42-43
	17AY21	42-43
	17AY24	42-43
	17AY27	42-44
	20AY21	42, 44-45
	Series A (No-Code or Code B)	39-41
	Series A (Code C or D)	41
	Series B (No-Code and Code 5)	41
	All chassis	45
<b>BENDIX</b>		<b>45-46</b>
	2025	45
	3033	45
	6002	45
	All chassis	45-46
<b>CALBEST</b>		<b>46</b>
	16-inch rectangular picture tube models	46
	17-inch rectangular picture tube models	46
	20-inch rectangular picture tube models	46
	19-inch round picture tube models	46
<b>CAPEHART-FARNSWORTH</b>		<b>47-66</b>
	A-2 series	47-48

MANUFACTURER	CHASSIS OR MODEL	PAGE
<b>CAPEHART-FARNSWORTH</b>		<b>47-66</b>
	A-3 series	47-48
	CX-30	47-50
	CX-31	50-51
	CX-33	51-63
	CX-33 with 19-inch picture tubes	63
	CX-33 with 20-inch picture tubes	63
	CX-33DX	63-66
<b>CBS-COLUMBIA</b>		<b>66-68</b>
	All chassis below 700-100 series	66
	700 series chassis	67
	All chassis	67-68
<b>CERTIFIED</b>		<b>68-69</b>
	49-10	68-69
<b>CROSLEY</b>		<b>69-78</b>
	1949 Models, LD series	69-70
	1950 Models	70
	1951 Models	70-71
	1952 Models	71
	1952 Models with 20- and 21" picture tubes	71-72
	1953 Models	71
	321	74
	321-1	74
	321-2	74
	321-4	75
	331	74
	331-1	74
	331-2	74
	331-4	75
	10-401	72-73
	10-402	73
	10-404	72-73
	10-404-MU	73
	10-404-MIU	73
	10-412	72-73
	10-412-MU	73
	10-414	72-73
	10-414-MU	73-74

MANUFACTURER	CHASSIS OR MODEL	PAGE
<b>CROSLLEY</b> .....		<b>69-78</b>
	10-416 .....	72-73
	10-416-MU .....	73
	10-416-MIU .....	73-74
	10-418 .....	72-73
	10-418-MU .....	73
	10-419-MU .....	74
	10-420-MU .....	73
	10-427-MU .....	74
	10-429-MU .....	73
	All Models .....	76-77
	Glass picture tube models .....	75-76
	Metal picture tube models .....	76
	Models with external agc adjustment .....	75
	DU-UHFP (UHF Converter) .....	77-78
 <b>DUMONT</b> .....		 <b>78-102</b>
	RA-101 .....	78-79
	RA-102 .....	78-79
	RA-103 .....	78-81
	RA-103C .....	79-81
	RA-103D .....	81-83
	RA-104A .....	81-84
	RA-105 .....	81, 84-86
	RA-105B .....	81, 86-87
	RA-106 .....	84-86
	RA-108A .....	81, 86-87
	RA-109 series .....	88-89
	RA-109A .....	89-93
	RA-110A .....	81-84, 87
	RA-111 series .....	88-89, 93
	RA-111A .....	89-90, 93-95
	RA-112 series .....	95-97
	RA-113 series .....	95-97
	RA-116A .....	97-98
	RA-117 series .....	95, 98-100
	RA-119A .....	88, 100-101
	All metal picture tube models .....	101
	All models .....	101-102



## ADMIRAL

Chassis 20A1,  
20B1, 20T1, 20V1, 20X1,  
through 20Z1, 21A1, 21B1,  
24D1 through 24H1, 30A1  
through 30D1

### Removing retrace lines.

In some areas, where the signal strength is low, it is often desirable to operate a receiver with the contrast reduced and the brightness turned up. Under these conditions, the picture may have several bright retrace lines. If the following changes are made to each type of chassis, the brightness control may be turned fully on without retrace lines appearing. The best way to apply these changes is to check the schematic diagram of the chassis and pencil in the changes before actually making them. For 20T1, 20V1, and 21B1 series of chassis:

1. Connect a 270,000-ohm,  $\frac{1}{2}$ -watt resistor (part No. 60B-274) in series with the wire going from pin 2 (grid) of the picture tube to the junction of C310 and R327.

2. Connect a .05- $\mu$ f capacitor (part No. 64B5-22) from pin 2 (grid) of the picture tube to the junction of the vertical wave shaping capacitor (C405 in 20T1 series and C406 in 21B1 series) and R407.

For 24D1, 24E1, 24F1, 24G1, and 24H1 chassis:

1. Connect a 270,000-ohm,  $\frac{1}{2}$ -watt resistor (part No. 60B8-274) in series with the wire going from pin 2 (grid) of the picture tube to the junction of C312 and R323.

2. Reverse the connections of the vertical wave shaping network (R410 and C406) by connecting the capacitor to the grid of V402 and the resistor to ground.

3. Connect a .05- $\mu$ f capacitor (part No. 64B5-22) from pin 2 (grid) of the picture tube to the junction of R410 and C406.

For 20A1, 20B1, and 21A1 chassis:

1. Insert a 270,000-ohm,  $\frac{1}{2}$ -watt resistor (part No. 60B8-274) in series with the wire connected from pin 2 (grid) of the picture tube to the junction of R325A and C313.

2. Connect a .05- $\mu$ f capacitor (part No. 64B5-22) from pin 2 (grid) of the picture tube to the junction of C405 and R408.

For 20X1, 20Y1, and 20Z1 chassis:

1. Insert a 270,000-ohm,  $\frac{1}{2}$ -watt resistor (part No. 60B8-274) in series with the wire connected from pin 2 (grid) of the picture tube to the junction of R317B and C320.

2. Replace R447 (3,900 ohms) with an 8,200-ohm,  $\frac{1}{2}$ -watt resistor (part No. 60B8-822) and readjust the height and vertical-linearity controls.

3. Connect a .05- $\mu$ f capacitor (part No. 64B5-22) from pin 2 (grid) of the picture tube to the junction of C408 and R447.

For 30A1, 30B1, 30C1, and 30D1 chassis:

1. Insert a 47,000-ohm,  $\frac{1}{2}$ -watt resistor (part No. 60B8-473) in series with the wire connected from pin 11 (cathode) of the picture tube, to the junction of R306B and C325.

2. Connect a .05- $\mu$ f capacitor (part No. 64B5-22) between the green wire of the vertical-output transformer and pin 11 (cathode) of the picture tube.

**ADMIRAL**Chassis 20A1,  
20B1, 21A1**Eliminating adjacent sound channel interference.**

In areas where any two adjacent channels may be received, the sound transmission from the lower channel may cause interference on the picture of the higher channel. This type of interference may be reduced to a minimum or eliminated by means of an adjacent channel trap fitted to the second video i-f amplifier transformer (*T302*).

The trap is constructed by using another sound trap, *L302*, part No. 72A88-1, which should be modified and installed in the receiver in the following manner:

1. Procure this sound trap (part No. 72A88-1) and remove two turns from the coil at the end farthest from the slug screw and resolder the coil to the lug on the form (do not remove the capacitor).

2. Clip the white lead and the bare tinned lead from the coil.

3. Remove the cover from the video i-f strip and locate *T302*.

4. Procure a short length (about 3 inches) of insulated 24- or 26-gauge wire and wind approximately  $1\frac{1}{2}$  turns in a clockwise direction on *T302*. These turns should be positioned on the small diameter portion of *T302* at the end farthest from the slug screw, with one end of the wire looped under itself, to hold the coil in position in a manner similar to the coupling coil of *T301*.

5. Connect one end of the  $1\frac{1}{2}$ -turn coil to the ground connection of *T302*.

6. In a large number of these chassis, an unused  $\frac{1}{4}$  inch hole will be found between *V302* and *V303*, but if the hole has not been punched, one should be drilled and the new trap inserted.

7. Connect the black lead from the new trap to the ground lug of *T302* and connect the loose end of the  $1\frac{1}{2}$ -turn coupling coil to the other lug on the new trap.

8. Realign the video i-f stages. Due to the slope of the video i-f curve, it is difficult to align the new trap to 27.25 mc with a signal generator, so the slug should be adjusted for minimum interference on the picture. However, care must be used when making this adjustment since it is possible to affect the video i-f bandpass if the adjustment is incorrectly made.

9. Use a sweep generator and scope to check the video i-f bandpass after adjustment to be sure the trap has not affected the i-f bandpass.

**ADMIRAL**Chassis 20B1,  
21A1**Interference due to harmonics of sound i.f.**

Harmonics from the sound i-f channel can cause herringbone patterns to appear on channels 3, 6, and 9. Check by removing the second sound i-f tube (*V-202*, 6AU6). If the interference persists, this is not the cause. If the pattern disappears, proceed as follows:

1. Replace the wire lead between the screen of this tube (pin 6 of *V-202*, 6AU6) and the 6,000-ohm resistor, *R-330* (*R-213* in revised

chassis), with a 1,000-ohm,  $\frac{1}{2}$ -watt resistor. Make the lead to the tube as short as possible.

2. Connect a 1500- $\mu\text{mf}$  ceramic capacitor from the junction of *R-330* with the focus control (*R-212B*) to the ground lug next to the socket of *V-202*.

3. Mount a terminal board under the mounting nut of the sound i-f transformer (*T-202*) near the video i-f shield.

4. Locate the lead between pin 7 of *V-306* (6AC7) and pin 3 of *V-202*. Remove it from *V-202* and connect it to an insulated lug on the terminal board.

5. Connect a filament r-f choke (part No. 73A2-1) from this lug to pin 3 of *V-202*.

6. Locate the ground lead from the socket of *V-203*, 6AL5, to a terminal board. Disconnect it from the terminal board and solder to the chassis beside the tube socket, making the lead as short as possible.

Note: Late production chassis incorporate this change.

**ADMIRAL** Chassis 20T1,  
20V1, 21B1 through 21H1,  
21J1 through 21L1, 21P1,  
21Q1

#### **Distorted sound due to misalignment.**

Distorted sound can be caused by misalignment of the ratio-detector transformer *T201*. This misalignment is sometimes due to frequency drift of the ratio-detector transformer. Realignment of the transformer may correct this trouble for a period of time, after which realignment may again be required.

A permanent remedy for this trouble is to connect a 20  $\mu\text{mf}$ , -750 temperature coefficient, ceramic capacitor (part No. 65B6-26) in parallel with capacitor *C204* (180  $\mu\text{mf}$ , ceramic, connected across the secondary of the ratio-detector transformer *T201*). Realign ratio-detector transformer after adding the 20  $\mu\text{mf}$  capacitor.

**ADMIRAL** Chassis 20T1,  
20V1, 21B1 through 21E1,  
21H1, 21J1

#### **Increasing sensitivity for fringe-area operation.**

The following hints may be helpful for improving sensitivity in fringe areas. These hints should be followed in the sequence given. The balance of the procedure can be omitted if satisfactory results are obtained at any point in the procedure.

1. Make sure that the proper antenna is used and that it is correctly installed.

2. Check the rectifier tube (5W4G) by substitution as the voltage output will vary slightly with tubes. An increase in B+ voltage will increase sensitivity.

3. Check the video-amplifier tube by substitution. Increased contrast is sometimes obtained with tube replacement.

4. Check the power-line voltage. If the voltage is known to vary greatly, it is recommended that the set be operated from a constant-voltage transformer with a power rating of at least 300 watts.

5. Carefully realign the receiver following the instructions given in the service notes. Checking tubes (by

substitution) in the r-f amplifier, oscillator-mixer, i-f stages, or video detector while aligning will often give considerable increase in gain. The increase in gain may be observed by an increase in amplitude of the response curve. Realignment of the particular stage should always be made after each tube replacement, in order to realize the maximum gain possible.

**ADMIRAL** Chassis 20T1,  
20V1, 21B1 through 21E1,  
21H1, 21J1

#### **Long warm-up time.**

A poor connection between the plate-cap lead and the plate cap connecting to the horizontal-output tube (6BQ6GT) may cause an excessively long warm-up period before the raster appears. This is sometimes caused by a poor solder connection. Touching a hot soldering iron to the solder joint inside the plate cap will often correct the trouble.

**ADMIRAL** Chassis 20T1,  
20V1, 21B1 through 21E1,  
21H1, 21J1

#### **Minimizing vertical bars.**

A filter may be added to eliminate or reduce to a minimum the brightness of shadow-type vertical bars which may appear at the left side of the picture.

This filter consists of resistor *R446* (680 ohms, 2 watts, part No. 60B20-68), capacitor *C432* (.0022  $\mu$ f, 600 volts, paper, part No. 64B9-17), and r-f choke *L405* (part No. 73B8-3). These components are all connected in parallel and are wired in the set between terminal 8 of the horizontal-

output transformer and pin 5 of the damper tube (6W4GT).

Before deciding that a filter is required in early sets giving this trouble, be certain that the horizontal drive and width controls have been adjusted according to the manufacturer's instructions. Also check to see that the picture-tube cathode lead (from pin 11) is not too close to the horizontal-output tube (6BQ6GT). This lead should be dressed as far away as possible from the horizontal-output tube.

If vertical bars are still present after picture-tube socket lead dress has been checked, install the filter. A pre-assembled filter complete with instructions is available from the Admiral distributor under part No. A3459S.

The filter must be placed inside the high voltage housing and *not* under the chassis.

**ADMIRAL** Chassis 20T1,  
20V1, 21B1 through 21E1,  
21H1, 21J1

#### **Horizontal tearing or bending.**

Horizontal tearing or bending may be caused by an excessively strong tv signal or by improper age action.

A strong signal can cause overloading of the video amplifier with resulting loss of sync pulses due to clipping. This overloading condition can be eliminated in chassis 20T1 and 20V1 by increasing the age voltage. To do this, remove *R302* (at test point *T*) from the circuit.

High-resistance leakage, between the control grid and other tube ele-

ments, in the r-f and i-f amplifier circuits may also cause clipping of the sync pulses. The tubes should be checked by replacement.

**ADMIRAL** Chassis 20T1,  
20V1, 21B1 through 21E1,  
21H1, 21J1

#### **Intermittent operation.**

Intermittent sound, picture, or sync in sets with a color-converter plug and socket may be caused by poor contact between the plug *M510* and the socket *M509*.

If poor socket contact is suspected as being the cause of trouble, remove the plug and tighten the socket contacts with a pair of long-nose pliers. Also, clean contact surfaces with carbon tetrachloride.

**ADMIRAL** Chassis 20T1,  
20V1, 21B1 through 21E1,  
21H1, 21J1

#### **Vertical foldover.**

Vertical foldover appears as a bright horizontal bar at the bottom of the picture, after the height and linearity controls are adjusted for correct picture size and linearity. Low line voltage (below 105 volts) can often be the cause of foldover in a set which is otherwise normal. Always check the line voltage first if this trouble appears. However, if foldover occurs at normal line voltage, it may be corrected by making one or more of the following changes in the order shown below (for chassis 20T1, 20V1):

1. *Tubes.* A weak vertical-output tube (*V402*) can be the cause of foldover; a number of new tubes should

be tried. This has been a source of trouble in sets using a 6S4 tube for a vertical-output tube. Some brands of 6S4 give a greater output, thus making it possible to obtain sufficient height without causing foldover. Low B+ voltage caused by a weak 5U4G rectifier tube (*V501*) will also cause foldover; try other rectifier tubes.

2. *Resistor change.* Change grid resistor *R410* from 1 megohm to 3.3 megohms, and decoupling resistor *R439* from 1000 ohms to 560 ohms, 1 watt.

3. *Additional capacitor across width control.* An additional capacitor (.01 to .05  $\mu\text{f}$ ) connected across width control *L402* will increase the sweep width and also provide increased vertical sweep without causing foldover. The second anode supply voltage will be decreased by several hundred volts after making this change. The decrease in brightness is not noticeable.

4. *Deflection yoke.* The cores of the deflection yokes used in these sets consist of two pieces of powdered iron, each semicircular in shape. For maximum efficiency, these two core pieces should fit closely together with the air gaps as small as possible. Inspect the iron cores in the yoke to see if the air gap is at a minimum. If the air gap is greater than 1/32 inch, tighten the collar. If this does not reduce the gap, remove the collar and the iron cores, and smooth over the insulation between the cores so that the gap will be at a minimum.

Some yokes are made so that the fibre sleeve must be clipped away with a pair of diagonal cutters before the collar and iron cores can be removed.





**ADMIRAL** Chassis 20T1,  
20V1, 24D1 through 24H1

### **Cleaning picture-tube window.**

For best results, wash the window with luke warm, soapy water, rinse with clear water, and dry with a soft, lint-free cloth with as little rubbing as possible.

If necessary, use *Dust-Ded* (part No. 98A11-2: 1/2 oz. bottle), or commercially available *Glim*, as a plastic cleaner and dust repellent.

Do not use other cleaners or solvents. Cleaners and solvents such as kerosene, carbon tetrachloride, and most of the kitchen-type cleaners may be injurious.

**ADMIRAL** Chassis 20T1,  
20V1, 24D1 through 24H1

### **Removing scratches on plastic parts.**

Most scratches on plastic parts can be removed satisfactorily. If the scratch or mar is slight, follow steps 3, 4, and 5 below. If scratch is deep, follow all steps below.

1. Sand the scratch with wet #400 (wet or dry type) sandpaper. Use plenty of water. Rub with free, easy, straight strokes and finish with light featherlike strokes.

2. Clean sanded area thoroughly by swabbing with wet cotton or a very soft cotton cloth, then dry thoroughly.

3. Apply a commercial household polishing agent to the plastic parts. Although many commercial polishing agents may be satisfactory, *Parka-Polish*, *Simoniz Kleener*, *Johnson's Carnu* and *Wright's Silver Cream* have been tried on Admiral plastic

parts and found suitable. Rub in with rapid, vigorous, straight strokes. It may take several minutes of this rubbing to produce satisfactory results.

4. Remove all trace of polishing agent by swabbing with damp cotton. Inspect results carefully.

5. Dry completely, and buff entire escutcheon with clean, dry cotton.

**ADMIRAL** Chassis 20T1,  
20V1

### **Horizontal picture jitter.**

Picture jitter may be caused by improper resistance value of *R420*, plate-load resistor of V401B (sync clipper). Check *R420* to see that it is 22,000 ohms.

**ADMIRAL** Chassis 20T1,  
20V1

### **Overloading in strong-signal areas.**

Resistor *R302* should be increased to 1.2 megohms to prevent overloading in strong-signal areas. When this change is made, the amount of negative a-gc voltage applied to the grid of the r-f amplifier is increased. This reduces the gain of this stage so that overloading does not occur.

**ADMIRAL** Chassis 20T1,  
20V1

### **Excessive picture height.**

Excessive picture height (which cannot be reduced by adjustment of the height control) can be due to tolerances of parts such as the deflection yoke and power transformer.

This condition may be corrected by removing capacitor *C431* (across

width coil) or replacing resistor *R408* (1-megohm plate resistor of vertical oscillator) with a 2.2-megohm resistor, part No. 60B8-225.

**ADMIRAL** Chassis 20T1,  
20V1

**Increasing sensitivity by reduction of agc voltage.**

Receiver sensitivity may be increased by connecting a 120,000-ohm resistor (part No. 60B8-124) between test point *T* and chassis ground. This resistor should *not* be used in an area where strong signals can be received, as overloading (bending or poor-quality picture) will result. Oscillation of the r-f stage may also occur if the set is used with an r-f booster. To prevent overloading, a switch may be installed in the ground end of the resistor to remove it from the circuit when a strong station is received.

A further increase in sensitivity may be produced by completely removing the agc voltage from the r-f tuner. This is done by removing the agc lead (white) of the tuner from the agc connecting lug and then grounding the lead to the chassis. As above, to prevent overloading, a switch (SPDT) should be installed so that the connection to ground is restored to its original connection for the reception of strong signals.

**ADMIRAL** Chassis 20V1  
**Picture-tube replacement causes excessive brightness.**

Due to the difference in manufacturing tolerance between various brands of picture tubes, it may be

found that replacing one brand with another will result in too much brightness, even with the brightness control turned fully off.

This may be corrected by connecting a 470,000-ohm, 1/2-watt resistor (part No. 60B8-474) across capacitor *C308* (0.1  $\mu$ f).

The resistor places a negative bias on the video-amplifier tube *V305* and decreases the current through this tube. By connecting the resistor across *C308* instead of between the grid of the video amplifier and ground, the d-c reinsertion is also improved.

The resistor is included in later runs of this chassis.

**ADMIRAL** Chassis 20V1  
**Increasing sweep width.**

A capacitor rated at .02  $\mu$ f, 400 volts (part No. 64B5-24) may be added across width control *L402* to increase sweep width in some sets. This change has already been made in later runs of this chassis.

**ADMIRAL** Chassis 20V1  
**Reducing sync buzz.**

Resistor *R213* should be changed from 270 ohms, 1 watt to 330 ohms, 1 watt (part No. 60B14-331). This change is made to reduce sync buzz and to reduce plate dissipation in the sound-output tube.

**ADMIRAL** Chassis 20X1  
through 20Z1  
**Reduction of intercarrier buzz due to misalignment.**

Where sync buzz is due to misalignment, it may be corrected with-

out the use of a sweep generator as follows:

1. Tune in the station with the loudest sync buzz.

2. Connect a vacuum-tube voltmeter between test point *Y* and ground. Test point *Y* is one plate of the ratio detector (pin 2 of *V-202*, 6AL5).

3. Adjust the primary slug of the ratio-detector transformer (*A5* of *T-201*) for maximum reading.

4. Adjust the slug of the sound i-f transformer (*A6* of *L-201*) for maximum reading.

5. Connect the meter between test point *Z* and ground, setting it for zero center reading. (Test point *Z* is the junction of the 4- $\mu$ f capacitor, *C-204*, and the 33,000-ohm resistor, *R-206*, located in the detector network.)

6. Adjust the secondary slug of the ratio detector transformer (*A7* of *T-201*) for center zero reading.

7. With the fine-tuning control centered, adjust the channel oscillator slug for minimum buzz. Rock it back and forth over a wide range to make sure the minimum position has been found.

8. Repeat step 7 for all other channels. The fine-tuning control can now always be used to adjust for minimum buzz with best picture.

## **ADMIRAL**

Chassis 20X1  
through 20Z1

### ***Intercarrier buzz due to stray capacitive coupling.***

Sometimes a properly aligned intercarrier receiver manifests residual sync buzz when tuned to a properly modulated television signal.

This is caused by stray capacitive coupling and is rarely at an objectional level. If it is excessive, proceed as follows:

1. With a station properly tuned in, disconnect the .01- $\mu$ f coupling capacitor (*C-208*) from the grid of the sound-output stage (pin 5 of *V-204*, 6AS5).

2. Connect approximately 1 inch of insulated wire to this pin.

3. Connect approximately 3½ inches of insulated wire to the terminal connected to the plate of the sync separator (pin 6 of *V-401B*, 12AU7).

4. Twist these leads together, a turn at a time, until the buzz is reduced to a minimum.

5. Reconnect the .01- $\mu$ f coupling capacitor (*C-208*) to its grid (pin 5 of *V-204*, 6AS5). If further reduction is necessary, proceed with the remaining steps:

6. Connect approximately 1 inch of insulated wire to the grid of the sound amplifier (pin 4 of *V-203A*, 6SN7).

7. Connect approximately 3 inches of insulated wire to the terminal board connected to the plate of the sync separator (pin 6 of *V-401B*, 12AU7). This is the same point referred to in step 3.

8. Twist these leads together, a turn at a time, for a further minimum in buzz.

## **ADMIRAL**

Chassis 20X1  
through 20Z1

### ***Intercarrier buzz due to improper transmitter modulation.***

Buzz frequently occurs in a properly aligned intercarrier receiver because of improper video modula-

tion at the transmitter. This type may be recognized by the fact that it increases when there is a large amount of white in the picture. It may be reduced or eliminated as follows:

1. Remove the 120- $\mu$ f capacitor (C-202) connected between the grid of the sound i-f amplifier (pin 1 of V-201, 6AU6) and the sound i-f transformer (L-201).
2. Replace it with a short length of wire.
3. Remove the 1-megohm resistor (R-201), connected between the grid of this stage (pin 1 of V-201, 6AU6) and ground.
4. Disconnect the cathode of this stage (pin 7) from ground.
5. Add an 82-ohm,  $\frac{1}{2}$ -watt resistor (part No. 60B28-31) between pin 7 and ground.
6. Realign the sound strip.

#### ADMIRAL

Chassis 20X1  
through 20Z1

#### Vertical foldover.

Replace vertical oscillator and output tube (V-402, 12AU7). If the condition is not remedied, try several tubes of various brands before suspecting the vertical-output transformer.

Note: Field reports and laboratory checks indicate that 80 percent of all complaints of this type can be traced to defective 12AU7's.

#### ADMIRAL

Chassis 20Z1,  
21B1, 21C1

#### Removing adjacent-channel interference (see Fig. 2).

The picture may have a herringbone interference pattern produced

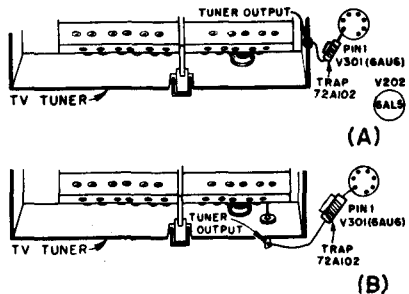

Fig. 2 — Admiral

by the adjacent lower channel sound carrier. Close examination will often reveal the fine lines of herringbone pattern varying in accordance with the speech or music on the adjacent lower channel. Since f-m interference from other sources also produces a herringbone pattern, the presence of a station on the adjacent lower channel should be definitely determined.

For chassis 20Z1, a trap, part No. 72A102, is available for removing such interference. This trap is fixed-tuned and consists of a coil and fixed capacitor resonant at 27.25 mc. The trap is connected by removing the lead between the r-f tuner and the grid (pin 1) of the first video amplifier V301 (6AU6) and connecting the trap in place of the lead. See part (A) of the figure for location. This trap may be installed in the field without realignment. Later production runs of the 20Z1 chassis will have the trap incorporated in production.

For chassis 21B1 and 21C1, a similar arrangement is used. See part (B) of the figure for location.



**ADMIRAL** Chassis 21B1  
through 21E1, 21H1, 21J1  
**Increasing sensitivity of tuner.**

In later production, resistor *R303* was changed from 1,000 ohms to 470 ohms, 1/2 watt, part No. 60B8-471. Changing this resistor to a lower value increases the B+ voltage applied to the r-f tuner, thereby providing an increase in sensitivity. This increased sensitivity will be apparent in fringe or weak-signal areas. This resistor change should be made only in sets having less than 105 volts at the r-f tuner B+ lead.

**ADMIRAL** Chassis 21B1  
through 21E1, 21H1, 21J1  
**Increasing sensitivity by reduction of agc voltage.**

Sensitivity may be increased by connecting a resistor between test jack *T* and chassis ground. Starting with a 1 megohm resistor, try lower resistance values until the correct size resistor is determined which will give satisfactory results for the particular location. Solder one end of the resistor to a banana plug and insert this banana plug into test point *T* jack; ground the other end of the resistor. Removal of the chassis from the cabinet is not required for installation of this resistor. Test jack *T* is the socket hole nearest the front of the chassis.

This change should not be made in an area where strong signals can be received, or overloading (bending or poor-quality picture) will result. Oscillation of the r-f stage may also occur if the set is used with an r-f booster. To prevent overloading, a

switch may be installed in the ground end of the resistor so as to remove the resistor from the circuit when a strong station is being received.

For a further increase in sensitivity, the agc voltage may be completely removed from the tuner. To do this, lift the agc lead (white) of the r-f tuner from its lug and connect to chassis ground. As above, this change should *not* be made where strong signals may be received since overloading will result. A changeover switch (SPDT) can be installed to apply agc bias to the r-f tuner when strong signals are to be received.

**ADMIRAL** Chassis 21B1  
through 21D1, 21J1  
**Replacing 12H6 with 6H6.**

If a 12H6 is not available for replacement, a type 6H6 tube may be used in place of the 12H6, providing that the following changes to the heater circuit are made:

1. Remove the transformer lead from pin 7 of the *V404* (12H6) socket. Tape the lead to prevent it shorting to chassis.

2. Connect a lead from pin 7 of *V404* socket to pin 7 of *V401* (6SN7) socket.

**ADMIRAL** Chassis 21B1  
through 21D1  
**Reduction of audio hum.**

Make sure a tube shield (part No. 87A8) is used when *V203* sound amplifier is a 6SQ7-GT (glass tube). Also, *C211* (plate circuit of sound amplifier *V203*) may be changed from .047  $\mu$ f to .47  $\mu$ f, 400 volts, part No. 64B9-72, to reduce audio hum.

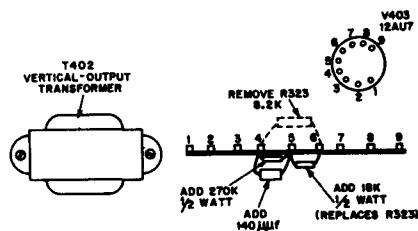
**ADMIRAL****Chassis 21B1,  
21C1****Improved noise immunity for  
horizontal sync (see Fig. 3).****Fig. 3 — Admiral**

In some areas where the noise level is high, the noise peaks may affect the sync circuit and cause the picture to shake horizontally or lose horizontal sync.

A change in resistor value and an additional filter in the sync circuit may be incorporated to reduce this trouble. The circuit change may be found already made in late runs of the chassis.

Early production receivers may be modified by following the procedure given below:

1. Locate a 9-lug terminal strip adjacent to the vertical-output transformer.

2. Remove *R323* (8,200 ohms) from lugs 4 and 6.

3. Connect an 18,000-ohm, 1/2-watt resistor (part No. 60B8-183) between lugs 5 and 6.

4. Connect a 140- $\mu\mu\text{f}$  capacitor (part No. 65B1-26) with a 270,000-ohm, 1/2-watt resistor (part No. 60B8-274) in parallel between lugs 4 and 5.

**ADMIRAL****Chassis 21B1,  
21C1****Second-anode lead arcing.**

A wire-lead support, part No. 19A66, is used to hold the picture tube second-anode lead on *21B1* and *21C1* chassis (16-inch rectangular tube). The wire-lead support used in early sets was 3-7/16 inches long; this placed the end of the support close to the picture tube second-anode connector to cause corona and arcing. The lead support has been shortened in later sets and is now 3-3/16 inches in length. The early (longer) type should be removed entirely or replaced with the later (shorter) type supplied under the same part number.

**ADMIRAL****Chassis 21B1,  
21C1****Adjacent lower channel sound  
interference.**

Later production sets have an adjacent lower channel sound trap (*L307*, *C314*) added between the connector lug (terminal of *C113*) on the tuner and pin 1 of the first i-f amplifier tube *V301*. This trap (part No. 72A102) is pre-tuned to 27.25 mc.

This trap will eliminate the herringbone interference pattern produced by the sound carrier of the adjacent lower channel in the same locality, especially when the wanted station is weaker than the interfering station. Close examination of this type of interference will reveal that the fine lines of the herringbone will vary in accordance with the speech or music on the adjacent lower channel. This can be checked by



quickly turning the channel selector to the lower channel.

Since f-m interference from other sources will also produce a herringbone pattern, it should definitely be determined that the interference is caused by the adjacent lower channel before installing the trap. After installing the trap, realign slug *A4*, (mixer plate coil *L103*).

**ADMIRAL** Chassis 21B1,  
21C1

**Improving sync stability.**

An R-C filter consisting of a parallel combination of a 270,000-ohm, 1/2-watt resistor (part No. 60B8-274) and a 150- $\mu$ mf, mica capacitor (part No. 65B21-151) is connected between resistor *R323* and capacitor *C308*. Resistor *R323* was changed from 8,200 ohms to 18,000 ohms, 1/2-watt (part No. 60B8-183). These changes will improve sync stability (immunity to noise) in areas having low signal strength and a high noise level.

**ADMIRAL** Chassis 21B1,  
21F1

**Preventing picture cut-off**  
(see Fig. 4).

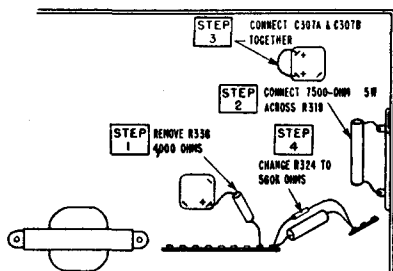

Fig. 4 — Admiral

Blocking may occur if the tv set is tuned to a very strong tv signal which could drive the video amplifier to cut-off. With the video amplifier at cut-off, B+ voltage applied to the cathode of the picture tube will increase, thereby making the grid voltage more negative with respect to cathode, and driving the picture tube to cut-off. Also, since the gated agc tube is dependent upon voltage from the video amplifier for its operation, blocking of the video amplifier will prevent agc voltage from developing and the system will remain blocked.

The following changes may be made to prevent possible picture cut-off due to blocking of the video amplifier.

1. Remove resistor *R336* (4,000 ohms).
2. Connect a 7,500-ohm, 5-watt resistor *R338* (part No. 61A1-18) across *R319*.
3. Connect together the positive terminals of filter capacitors *C307A* and *C307B*.
4. Change resistor *R324* from 180,000 ohms to 560,000 ohms, 1/2 watt (part No. 60B8-564).

**ADMIRAL** Chassis 21B1  
**Reducing picture smear**  
(see Fig. 5).

Picture smear or poor picture definition may be caused by improper receiver tuning to avoid receiving 4.5-mc beat interference. The natural tendency is to tune the set to eliminate the 4.5-mc interference in the picture, but this results in incorrect setting of the fine-tuning control for best picture.

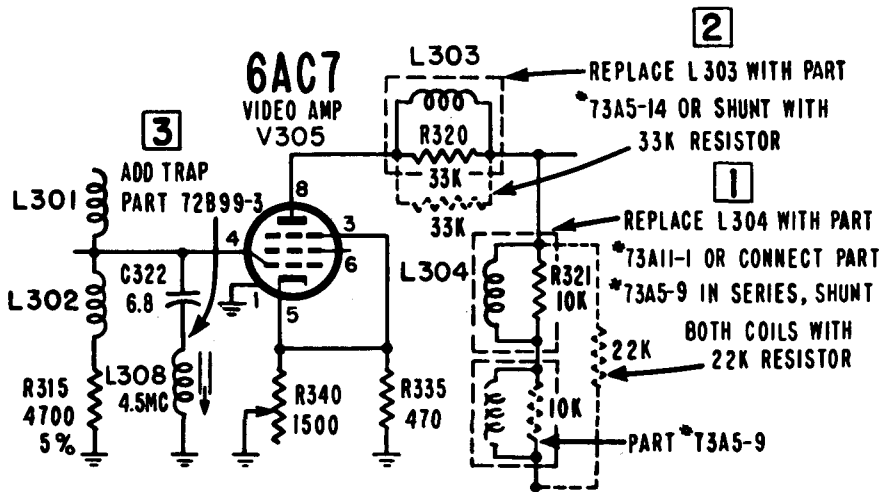

Fig. 5 — Admiral

To reduce or eliminate 4.5-mc interference in the picture, the following is recommended. Note: Some later production sets may have this change incorporated.

1. Remove peaking coil *L304* (part No. 73A5-9) and replace it with peaking coil, part No. 73A11-1. Peaking coil 73A11-1 has a three pi winding. If part No. 73A11-1 is not available, use two 73A5-9 peaking coils connected in series, with short leads, so that the coils are not more than  $\frac{3}{4}$  inch apart. Connect a 22,000-ohm,  $\frac{1}{2}$ -watt resistor (part No. 60B8-223) across this two-coil assembly.

2. Remove peaking coil *L303* (part No. 73A5-13) and replace it with peaking coil, part No. 73A5-14. Peaking coil 73A5-14 is coded with a blue dot. If part No. 73A5-14 is not available, part No. 73A5-13 should be left in the receiver and a 33,000-ohm,  $\frac{1}{2}$ -watt resistor (part No. 60B8-333) should be wired across it.

3. Connect a series resonant trap *L308*, part No. 72B99-3 (used in 20T1 receivers), between pin 4 of *V305* (6AC7) and chassis ground. Mount the trap in the chassis hole located between tubes *V305* (6AC7) and *V403* (12AU7), with the 6.8- $\mu$ mf capacitor *C322* connected to pin 4 of *V305*.

4. The trap should be tuned by watching the picture and adjusting the slug for minimum 4.5-mc interference. If greater accuracy is required, the trap should be adjusted in the following manner:

Using clip leads, short circuit pin 1 of *V201* (6AU6) to chassis ground and connect a 50- $\mu$ mf capacitor between pin 8 of *V305* and pin 7 of *V201*. Set the channel selector to the tv station having the strongest signal. Tune the fine-tuning control for loudest sound. Using a nonmetallic alignment screwdriver, carefully adjust the trap slug for minimum sound. Warning: Do not attempt to adjust

the 4.5-mc trap by using a grid dip meter since the reading will not be correct.

**ADMIRAL** Chassis 21D1,  
21J1

**Obtaining sufficient width.**

*C433* (shunted across width coil) is .002  $\mu\text{f}$ , .0047  $\mu\text{f}$ , or .01  $\mu\text{f}$ , 600 volts, as required to obtain sufficient width. Increasing the size of capacitor *C433* provides greater sweep width with slight reduction in picture brightness. When adding or replacing *C433*, use the smallest capacitance possible which will produce sufficient sweep width.

**ADMIRAL** Chassis 21D1

**Increasing range of vertical-linearity control.**

*R411* (cathode circuit of vertical-output tube) may be changed from 820 ohms,  $\frac{1}{2}$  watt to 680 ohms, 1 watt (part No. 60B14-681) to increase range of the vertical-linearity control *R410*.

**ADMIRAL** Chassis 21D1

**Poor vertical linearity or foldover.**

Poor vertical linearity or vertical foldover may be eliminated by replacing *R411* (820 ohms) with a 680-ohm, 1-watt resistor, part No. 60B14-681. All later production 21D1 sets have this change incorporated. Before making this change it is suggested that another vertical-output tube (*V402*) be tried since this may be the cause of the trouble.

**ADMIRAL** Chassis 21D1

**Vertical roll.**

In some sets enough 60-cycle ripple from the vertical-output stage may be present in the B+ supply to appear in the sync circuits. This ripple voltage will occasionally be strong enough to trigger the vertical oscillator. If this 60-cycle ripple has shifted in phase with respect to the original vertical-output signal, it will cause vertical roll (loss of vertical sync).

This condition can be corrected by changing the B+ connections of the vertical-output tube *V402* (6W6GT) as follows:

1. Locate the red lead from vertical-output transformer *T402* which connects to the terminal strip directly below the transformer. Also locate the white lead with black tracer (from the deflection yoke) which connects to same terminal. Disconnect both leads from terminal strip.

2. Connect both leads to the junction of *C427* and *L403*, through a 5,000-ohm, 5-watt decoupling resistor (part No. 61A1-8). The decoupling resistor may be three 15,000-ohm, 2-watt resistors (part No. 60B20-153) connected in parallel.

3. Connect a 20- $\mu\text{f}$ , 450-volt electrolytic capacitor (part No. 67A21-1) from the junction of the two leads and the decoupling resistor to chassis ground. Connect the negative terminal of the capacitor to chassis ground.

**ADMIRAL** Chassis 24D1  
through 24H1

**Easier alignment of 4.5-mc trap.**

Test-jack connector for injection of the 4.5-mc signal should be

changed from junction of L302 and L303 to plate (pin 7) of the video detector V304. This results in a more definite dip at 4.5 mc when aligning the 4.5-mc trap (L303 and C307).

**ADMIRAL** Chassis 24D1  
through 24H1

**Increasing brightness-control range.**

Picture tube brightness range may be increased by changing resistor R322 from 100,000 ohms, 1/2 watt to 33,000 ohms, 1/2 watt (part No. 60B8-333). With this change, the brightness control will completely cut off the picture tube beam current when the picture control is advanced all the way.

**ADMIRAL** Chassis 24D1  
through 24H1

**Reducing parasitics in horizontal-output tube.**

A 100-ohm, 1/2-watt resistor R448 (part No. 60B8-101) may be added to the 6CD6 screen-grid circuit to reduce parasitic oscillations in this circuit. These oscillations will generally cause a double image with a wavy effect.

**ADMIRAL** Chassis 24D1  
through 24H1

**Preventing static charge on chassis.**

A 270,000-ohm, 1/2-watt resistor R503 (part No. 60B8-274) may be added from one side of the 117-volt a-c line to ground to provide a dc

return for any static charge that might build up on the chassis.

**ADMIRAL** Chassis 24D1  
through 24H1

**Eliminating picture ripple due to hum pick-up.**

To reduce 60-cycle pick-up, which produces a continual, very slowly moving wiggle or ripple in the picture, a 2-inch copper band may be added to each side of the power transformer T501. This condition is only possible in areas where the power source for the station is different than for the receiver. All service replacement transformers will have the 2-inch copper band already installed on each side.

Note: The power transformer is mounted on top of the chassis in early production sets, and is mounted underneath on later production sets.

**ADMIRAL** Chassis 24D1  
through 24H1

**Static charges on picture-tube window.**

A ground wire and spring clip are used in all but early production sets, with round picture tubes, to eliminate any static charge that might be present on the picture window, cabinet, or control escutcheon. These static charges might also result in corona effects.

These early picture windows (part No. 23D61 for 16-inch sets and part No. 23D62 for 19-inch sets) can be grounded by connecting ordinary braided shield from the mounting screw on the lower right-hand corner of the picture window to chassis.

**ADMIRAL**Chassis 24D1  
through 24H1**Horizontal linearity affected by  
horizontal-hold control.**

Resistor *R430*, which is used for feedback from one section of the horizontal oscillator to the other, was changed in some sets from 1,500 ohms to 1,600 ohms. It is preferable to have a resistance of 1,600 ohms in this circuit. However, in most chassis a resistance of near 1,600 ohms was obtained by using 1,500-ohm resistors with a positive tolerance. If this resistance is lower than specified, the horizontal linearity will change to a large degree with different *horizontal hold* settings.

**ADMIRAL**Chassis 24D1  
through 24H1**Arcing from 6S4 socket to chassis.**

In early sets, arcing might occur between pin 9 of the 6S4 vertical-output tube socket and ground. This will cause damage to the socket and to the 2,200-ohm, 2-watt dropping resistor *R417*. If this happens, replace the socket with later production socket, part No. 87A25-3. Also replace resistor *R417*, part No. 60B14-222, even though it might check OK with an ohmmeter.

**ADMIRAL**Chassis 24D1  
through 24H1**Short-circuit hazard caused by  
mounting bolts.**

In early production "television only" models, the chassis is mounted on a mounting board with  $1\frac{1}{4}$ -inch mounting bolts. The mounting bolt near the *horizontal width* control

might short circuit the width control, resulting in insufficient width, horizontal nonlinearity, and loss of picture brightness, or no raster at all.

To correct, pull the mounting board four or five inches out of the cabinet to remove the mounting bolt, then place four or five washers under the bolt head. Late production sets use a shorter bolt.

When installing chassis, do not use a sharp pointed tool for locating this mounting hole, as the width-control winding might be damaged.

**ADMIRAL**Chassis 24D1  
through 24H1**Eliminating adjacent-channel  
interference (see Fig. 6).**

Fig. 6 — Admiral

Two adjacent-channel traps *L309* (27.25 mc) and *L310* (19.75 mc) may be added between the output of the tv tuner and the input of the first video i-f amplifier *V301* (6AU6). This is done to eliminate the possibility of interference from the video carrier of the adjacent channel above, and the sound carrier of the adjacent channel below, the desired channel.

This interference might be evident if two stations are operating on adjacent channels in the same locality,

especially when the wanted station is weaker than the interfering station.

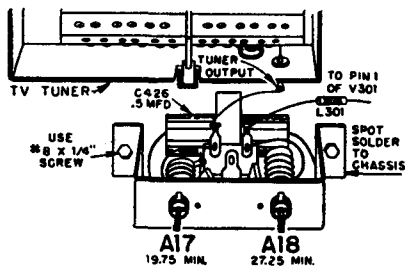
Adjacent channel interference may take either of these two forms:

1. *Adjacent-channel video interference.* The picture has an interference pattern produced by the video carrier of the adjacent *higher* channel. Sometimes the interference will appear as a superimposed picture (stationary or moving slowly); at other times it may appear as a number of diagonal lines or as a vertical moving bar.

2. *Adjacent-channel sound interference.* The picture has a herringbone interference pattern produced by the sound carrier of the adjacent *lower* channel. Close examination will often reveal that the fine lines of the herringbone pattern vary in accordance with the speech or music on the adjacent lower channel. This can be checked by quickly turning the channel selector to this station.

Since these types of interference effects can also be produced by other sources of interference, and also by misalignment of the video i-f amplifiers and traps, trouble from these sources should be checked before deciding traps are required.

The 19.75-mc trap will remove adjacent-channel video interference, and the 27.25-mc trap will remove adjacent-channel sound interference.

A complete Adjacent Channel Trap Assembly (includes *L309*, *L310*, *C313*, *C314* and mounting bracket) is supplied under part No. A3320.

To install the adjacent channel trap assembly, proceed as follows:

Fit the legs of the bracket over capacitor *C426* so that the left mount-

ing foot lines up with the unused hole in the chassis (to the left of *C426*). Secure the left mounting foot to the chassis with a #8— $\frac{1}{4}$  inch self-tapping screw. Spot solder the other mounting foot to the chassis to save drilling a new hole.

Unsolder *L301* from the tv tuner output and solder it to the empty lug on the assembly. It may be necessary to extend the lead on *L301* with a small piece of wire. Connect the base lead from the other lug to the tuner-output lug.

After installation, the traps should be aligned so that minimum interference is produced.

## ADMIRAL

Chassis 24D1  
through 24H1

### *Arcing or corona discharge.*

Arcing or corona in the second anode supply circuit of the picture tube will generally produce a sharp crackling noise in the sound of the receiver, a faint hissing sound, noise pulses in the picture, and/or an odor of ozone. It can also cause the raster to vary in brightness. Arcing or corona is generally aggravated in high humidity areas.

In general, the exact spot of arcing or corona can be located by close observation under subdued light. However, if arcing or corona is not visible, it might be located by listening through a length of fibre or bakelite tubing (approximately 1" diameter, at least 18" long). Hold the tubing close to the ear with the other end directed at the suspected point of arcing or corona.

Check for arcing or corona from the front of the picture tube to the

picture window, or between control escutcheon and the control shafts, by removing the chassis from the cabinet.

If the arcing or corona stops when the chassis is removed, follow the steps below.

1. If arcing or corona is in sets with 16-inch round or 19-inch picture tubes, check to see if the picture window is grounded to chassis with a braided shield and spring.

If trouble persists after re-installing chassis with grounding spring, or if trouble is in a set using 16-inch rectangular tube, proceed with steps below.

2. Clean the picture tube.

3. Clean the picture window.

4. Check the polyethylene sheet which is mounted to the cabinet from behind the picture window. Remove the polyethylene sheet and clean it with carbon tetrachloride. If the insulating sheet is deteriorated, torn, or has deep scratches or holes, replace it. When replacing, it is important to use short mounting staples placed as far to the top or sides of the cabinet as possible. Do not place the tacks too near the edge of the sheet.

If the place of arcing or corona cannot be located by using the above methods, disconnect the second-anode lead from the picture tube. To remove the second-anode lead in sets with 16-inch rectangular and 19-inch round tubes, it is only necessary to disconnect the second-anode lead plug from its socket. In sets with 16-inch round tubes, loosen the left side of the picture tube mounting rod, open the polyethylene ring at the top of the picture tube, and lift the second anode contact spring from the metal edge of the tube.

If the corona or arcing stops when the second-anode lead is disconnected, the arcing or corona is around the picture tube. Proceed as follows:

1. If trouble is with 16-inch round or 19-inch picture tubes, check the cone-shaped polyethylene sheet which fits over the picture tube. Be sure that it is free of moisture. If sheet is deteriorated, torn, or has deep scratches or holes, replace it. Note that some sets do not use this polyethylene cone.

2. Check to see that the polyethylene ring at the front of the tube and rubber collar around the neck of the tube are free from moisture, clean, and in good insulating condition.

3. If trouble is in a 19-inch picture tube assembly, check the second-anode lead connector. Push the connector together for good contact. If the connector does not fit together tightly, tape it together. If it is too tight, trim the excess material off with a file or sharp knife.

If the arcing or corona does not stop when the second-anode lead has been disconnected, the trouble lies in the second-anode supply in the chassis. Isolate and repair as follows:

1. Check for arcing or corona across high-voltage capacitor (*C435*). Clean surface of capacitor and capacitor-mounting strip with carbon tetrachloride. If necessary, replace capacitor.

2. Check to see that resistor *R445* is equally spaced between the sides of the socket bottom cover (corona ring). To remove the socket and components from the corona ring cover,

it is only necessary to insert a screwdriver between the socket and cover and twist the screwdriver.

3. Check for arcing or corona between terminals, leads, or windings (connections 1, 2, and 3) of the horizontal-output transformer. If arcing occurs across terminals, check for protruding edges of solder or strands of wire. If arcing occurs between wire leads, separate leads. If insulation is not burned badly, the surface of wire and terminal may be cleaned with carbon tetrachloride and the part might still be usable.

#### **ADMIRAL**

**Chassis 24D1  
through 24G1**

#### **Reducing audio buzz from vertical oscillator.**

A shield added between the vertical-oscillator tube and audio-output tube prevents possibility of 60-cycle (vertical repetition rate) pick-up in the audio amplifier and audio-output section. This shield (part No. 15B625) is in all 24H1 chassis, and holes are available on early 24D1, 24E1, 24F1, 24G1 chassis. Use two #8-32 self-tapping screws for mounting the shield.

#### **ADMIRAL**

**Chassis 24D1  
through 24G1**

#### **Breakdown of capacitor C214.**

To prevent breakdown, change C214 (plate bypass in audio-output stage) from .0022  $\mu\text{f}$  at 600 volts to a .0022  $\mu\text{f}$  at 1,000 volts (part No. 64A2-11). This change may be found already made in some runs of this chassis.

#### **ADMIRAL**

**Chassis 24D1  
through 24G1**

#### **Improving focus-control operation.**

Due to variations in tube characteristics of short-neck picture tubes, it was necessary to add R328 (22,000 ohms, 2 watt) to some receivers in early production runs. Other receivers did not have this resistor. In a few sets, a compromise resistor of 15,000 ohms was used.

If focusing difficulty is encountered in any chassis, determine if resistor R328 is necessary by checking as follows:

1. Picture will focus only with focus control all the way to the right (clockwise). Add R328 (22,000 ohms, 5 watt, part No. 60B20-223).

2. Picture will focus with focus control all the way to the left (counterclockwise). Remove R328.

If adding or removing R328 does not help, try changing the 6V6GT audio output tube (V205).

#### **ADMIRAL**

**Chassis 24D1**

#### **Horizontal jitter.**

There are some receivers in which horizontal instability or jitter may be caused by some of the horizontal-oscillator signal being fed to the grids of the first and second i-f stages along with the agc voltage. This signal, which has naturally shifted in phase with respect to that at the horizontal oscillator itself, will modulate the video signal and cause horizontal instability when fed back through the sync circuits.

This condition can be corrected as follows: Connect a .1- $\mu\text{f}$  capacitor from the junction of resistor R434 and R435 to ground.



**ADMIRAL**Chassis 30A1  
through 30D1**Pulling at top of picture.**

Complaints have been reported concerning pulling at the top of the picture. This pulling shows up across the top of the picture and extends approximately 1 inch down from the top of the picture. It can be noticed when there are vertical lines running to the top of the picture or pattern. These lines will pull to the right or left for a distance of 1 inch from the top of the picture.

This trouble is caused by a portion of the vertical-sync pulses riding through the horizontal-sync discriminator circuit and upsetting the horizontal oscillator momentarily. As the vertical-sync pulses occur 60 times per second this out-of-phase condition would exist immediately after the vertical-blanking pulses and therefore show up in the top portion of the picture only. The low-frequency response of the horizontal-sync discriminator can be reduced to overcome this problem. It is recommended that resistors *R413* and *R414* be changed from 470,000 ohms each to 180,000 ohms each. It will then be necessary to readjust the horizontal oscillator as described in the service notes.

**ADMIRAL**Chassis 30A1  
through 30D1**Increasing audio output.**

To increase the audio output for fringe-area operation, the following changes can be made:

1. Remove *R620* (150,000 ohms) in the 4H1 tuner chassis.
2. Increase the values of *R219* and *R220* (15,000 ohms) ratio-detector

load resistors to 27,000 ohms (part No. 60B7-273).

3. Remove the *6AG5* r-f amplifier (*V101*) grid return from the center arm of *R306A* control and connect to junction of *R305* and *R307*. This fixes the grid bias on *V101* at about 1.25 volts, resulting in more r-f gain. However, if the receiver is located in an area where strong signals may be received as well as weak signals, this change may cause improper operation of the contrast control on the strong signals. If this happens, fix the bias at a higher negative value by reversing the grid return from the video i.f. and *V101* from the original wiring as shown in the schematic. Change the i-f grid return from junction of *R304* to *R305* to the center arm of the contrast control. The grid return of *V101* should then be changed from the contrast control arm to junction of *R304* and *R305*.

4. Realign the ratio-detector transformer.

5. Check the *6AU6* tubes (*V201* and *V202*) in the audio i.f. Be sure these are good tubes.

6. Change the *6K6GT* audio-output tubes to *6V6GT* (*V512* and *V513*). No circuit change is required.

The above changes will improve audio sensitivity and output, but it is recommended primarily for receivers where the complaint is low volume on tv in fringe operation. It will be found that in some areas the tv transmitter is only deviating its audio transmission 7 to 10 kc instead of the allowable 25 kc; this will result in low audio at the receiver.

If the station is found to be the cause of low tv audio, these changes

will improve, but may not completely cure, the condition.

### **ADMIRAL** Chassis 30A1 **Unsealing slug adjustment.**

Since transformer 72B58 (first audio r-f transformer) can be detuned by vibration during shipment, the slug in these units was sealed with glyptal. In the event that alignment adjustment is necessary, a few drops of solvent should be applied to the glyptal around the slug. The slug will be free a short time after the application of a solvent. Alignment adjustment can then be made in the usual manner.

Several types of solvent can be used on glyptal. Lacquer thinner or amyl acetate (banana oil) are commonly used types.

### **ADMIRAL** Chassis 30D1 **Excessive oscillator drift.**

High ambient temperatures encountered under certain operating conditions may result in excessive oscillator frequency drift in some 94C8-2 tuners. Under such conditions, frequency readjustment of the fine-tuning control will be necessary. In some cases, oscillator drift may even go beyond the normal tuning range of the fine-tuning control.

This condition is most probable in the above chassis due to higher operating temperatures in this model.

When excessive oscillator frequency drift is encountered in a 94C8-2 tuner, the following part change will correct this condition: Replace old part *C109* (part No. 98A45-28), which is a 10- $\mu\text{mf}$ , -300

temp. coefficient ceramic capacitor with a 10- $\mu\text{mf}$ , -750 temp. coefficient ceramic capacitor (part No. 65B6-33).

Capacitor *C109* is accessible by removing the cover plate located on the side of the chassis pan, next to the tuner. Capacitor *C109* is connected between the second turret contact block terminal (from front of chassis) and ground.

After replacement of *C109*, the oscillator must be realigned by means of trimmer *C110*. Realignment should be made either with a tv signal on the highest available channel in your area or on channel 13 with a signal generator.

### **ADMIRAL** Chassis with metal picture tubes **Horizontal-oscillator radiation.**

Whistles throughout the broadcast band can be caused by radiation from the horizontal-sweep circuit of a television receiver using a metal cone picture tube. These tubes do not have an aquadag coating on the inner and outer surfaces of the cone as glass tubes do. These coatings act as an additional filter for the second anode supply and reduce radiation.

The addition of a 500- $\mu\text{mf}$ , 20-kv capacitor from the second-anode lead to ground (after the filter capacitor in the h-v housing) will reduce the radiation appreciably on receivers using metal-cone tubes. Connections between the second-anode lead and the bypass capacitor should be made carefully to avoid corona.

Additional attenuation of the radiation can be obtained in some cases by installing a .1- $\mu\text{f}$ , 600-volt capacitor from each side of the a-c line to ground.



**AIR KING** 700-series Chassis  
**Increasing vertical sync stability**  
(see Fig. 7).

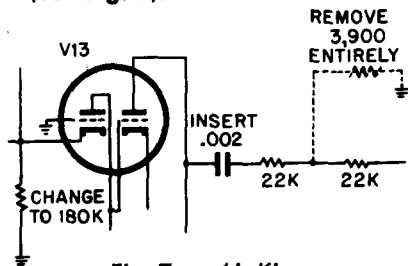

Fig. 7 — Air King

To increase vertical sync stability a .002- $\mu$ f capacitor should be inserted between the 22,000-ohm resistor and plate (pin 1) of the sync amplifier and phase splitting tube (V-13) as shown in the drawing. In conjunction with this change the 3,900-ohm resistor from the junction of the 22,000-ohm resistor to ground should be removed.

To further improve vertical sync stability in strong signal areas, change the 270,000-ohm cathode resistor of V-13 to 180,000 ohms. These changes are now being incorporated in later production runs.

**AIR KING** 700-series Chassis  
**Audio buzz.**

An audio buzz or hum in some chassis of the 700 series may be due to poor contact of the aquadag coating of the Hytron 16RP4 tubes with the grounding strap. It has been found that under certain conditions of humidity, the binder used in the aquadag will form a chalky coating

which prevents proper contact between the aquadag and the grounding strap.

This can be corrected by carefully washing the area around and under the contact spring, using a cloth moistened with water. After the area around the grounding spring has been washed and dried, it should be blackened by the application of graphite from a very soft pencil. Caution: The set must be shut off and the high-voltage supply discharged when this is done. No other type picture tube should be washed in this manner because most standard aquadag coatings are water soluble and would be removed if washed.

**AIR KING** Chassis 700-10 or later

**Horizontal foldover.**

When the afc control is correctly adjusted in the Air King chassis 700-10 or later series, the picture will fall into horizontal sync instantly when changing from station to station and it should be stable.

Sometimes this cannot be done without causing a foldover on either the right or left side of the picture. When this condition is present, it is an indication of unstable horizontal hold due to incorrect phasing from the transmitter. At certain adjustments of the afc control, the picture will jitter violently. To correct this condition, the 2,700-ohm phasing resistor (R52) will have to be increased to approximately 5,000 ohms if the foldover is on the left side of the picture or decreased to about 1,000 ohms if the foldover is on the right side of the picture.

**AIR KING** Chassis 700-10,  
-20, -30, -40, -50

**Reducing decoupling resistor failure.**

To reduce failure of *R48* (plate decoupling resistor of vertical-output stage), this resistor may be changed from a 1-watt type to a 3,300-ohm, 2-watt 10% resistor.

**AIR KING** Chassis 700-10,  
-20, -30, -40, -50

**Improving agc stability.**

To improve agc stability, the following changes may be made:

1. *C6* is changed from .1  $\mu\text{f}$ , 200 volts to .25  $\mu\text{f}$ , 200 volts.

2. *C9* is changed from .005  $\mu\text{f}$ , 600 volts to a ceramic capacitor rated at 22  $\mu\text{f}$ , 600 volts,  $\pm 20\%$ .

3. A resistor, *R77* (270,000 ohms,  $\frac{1}{2}$  watt,  $\pm 10\%$ ) is added between the cathode of the picture tube and the arm of the brightness control.

**AIR KING** Chassis 700-10,  
-20, -30, -40, -50

**Improving vertical linearity.**

To improve vertical-sweep linearity and the operating point of the vertical-output tube, the following changes are made:

1. *R49* (fixed cathode resistor in vertical-output tube) is changed from 330 ohms to 1,000 ohms.

2. *R43* (grid resistor of vertical-output tube) is changed from 3.3 megohms to 1.5 megohms.

3. *R86* (3,300 ohms, 2 watts) is added in series with the low end of the vertical-output transformer primary.

4. *C35* (coupling capacitor to vertical-output tube) is changed from .01  $\mu\text{f}$  to .02  $\mu\text{f}$ , 600 volts.

**AIR KING** Chassis 700-10,  
-20, -30, -40, -50

**Increasing audio sensitivity.**

Audio sensitivity may be increased as follows:

1. *R20* (screen-grid bleeder for ratio-detector driver) is removed.

2. *C16* (coupling capacitor between video amplifiers) connection to junction of *R69* and *L11* (plate circuit of first video stage) is changed to pin 1 of the 12BH7 video amplifier.

**AIR KING** Chassis 700-10,  
-20, -30, -40, -50

**Improving immunity to noise of vertical triggering.**

More stable vertical triggering in the presence of noise is achieved as follows:

1. *C16*, coupling capacitor between video amplifiers, is changed from .01  $\mu\text{f}$  to .05  $\mu\text{f}$ , 600 volts on all 16-inch and 19-inch chassis.

2. *R26* (3,900 ohms,  $\frac{1}{2}$  watt,  $\pm 10\%$ ) is added in the integrating circuit between *R38* and *R39*.

**AIR KING** Chassis 700-10,  
-20, -30, -40, -50

**Improving horizontal linearity.**

The following changes may be made in order to improve horizontal linearity:

1. *C62*, in the cathode circuit of the damper, is changed from .1  $\mu\text{f}$  at 600 volts to .05  $\mu\text{f}$  at 600 volts.

2. *C50*, connected between one side of the horizontal-deflection coils and the horizontal-output transformer, is changed from .25  $\mu\text{f}$  to a 25- $\mu\text{f}$ , 12-volt electrolytic capacitor.

**AIR KING** Chassis 700-90  
**Improving vertical sync stability.**

The following changes will improve the vertical sync stability:

1. Add a 27,000-ohm resistor from pin 1 to pin 3 of *V13* (12BH7).

2. Change *R36*, the cathode resistor of the sync splitter, from 2,700 ohms to 3,300 ohms.

3. Change *R37*, the plate resistor of the sync splitter, from 3,900 ohms to 8,200 ohms.

**AIR KING** Chassis 700-90  
through 700-96

**Improving sync stability.**

The following changes may be made to improve sync stability:

1. *R33*, cathode resistor of the d-c restorer is changed from 270,000 ohms to 180,000 ohms.

2. *R36*, cathode resistor of the sync splitter, is changed from 2,700 ohms to 3,300 ohms.

3. *R82* (27,000 ohms), an additional resistor, is connected between pins 1 and 3 of *V13* (12BH7).

4. *C69* (.002  $\mu\text{f}$ ), an additional capacitor, is inserted between *R38* and pin 1 of *V13*.

**AIR KING** Chassis 700-90  
through 700-96

**Eliminating horizontal foldover.**

Horizontal foldover may be eliminated by changing *C61*, connected between *C38* and *C39*, from .005  $\mu\text{f}$  at 600 volts to .01  $\mu\text{f}$  at 600 volts.

**AIR KING** Chassis 700-93

**Audio buzz.**

A small number of 700-93 chassis have been shipped which were found to have a considerable amount of hum or buzz. This can be corrected by putting a shield over the glass 6SQ7 tube, providing the 6SQ7 is of the metal ring base type. Substitution of a metal 6SQ7 will have the same effect.

**AIR KING** All 16-inch Chassis  
**Increasing range of contrast control.**

1. *R10*, in agc filter network, is changed from 2.2 megohms to 1 megohm.

2. *R76*, in the grid circuit of the first-video amplifier, is changed from 1 megohm to 3.3 megohms.

**AIR KING** All 16-inch Chassis  
**Improving sync stability.**

An improvement in sync stability may be produced as follows:

1. *R32*, in the picture-tube grid circuit, is changed from 3,900 ohms to 1,800 ohms.

2. *R34*, grid resistor of the sync clipper, is changed from 3.3 megohms to 1 megohm.

3. *R52*, connected between terminal 6 of the horizontal-output transformer and the horizontal-phase detector, is changed from 6,800 ohms to 2,700 ohms.

4. *R83* (1,000 ohms,  $\frac{1}{2}$  watt,  $\pm 20\%$ ) is added between side of *C14* and ground.

5. *R17*, cathode bias resistor of first-video amplifier, is changed from 560 ohms to 330 ohms.



## **ANDREA**

## **All Chassis**

### **Intermittent picture-tube operation.**

In many cases, intermittent operation of picture tubes has been traced to an intermittent contact at the picture-tube socket or a poor soldering contact on the tube pins.

Before removing picture tubes from sets, check for intermittent connections at the tube socket. It is also advisable to apply a hot soldering iron to each of the tube pins to be sure of good soldering connections within the tubes themselves.

## **ANDREA**

## **VL-series Chassis**

### **Precise dial calibration.**

If it is found that precise calibration of the dial cannot be had due to the position in which the gears engage, remove the tuning dial, loosen the set screw, and turn the shaft slightly so that the gear of the dial engages the gear of the tuning unit at a position that will give more accurate dial calibration.

## **ANDREA**

## **Chassis VL-12, VL-16, VL-19**

### **Improper antenna-transformer connections.**

When the 300-ohm antenna matching transformer is used, the transmission line should be connected to the 300-ohm post connections. Besides this connection, the 72-ohm posts must be connected to the receiver terminals marked *AA*. This latter connection is necessary in order to complete the circuit.

The 300-ohm to 72-ohm antenna matching transformer, part No. S-13, does not come equipped on chassis VL-12, but can be obtained from the manufacturer to be used with this model.

## **ANDREA**

## **Chassis VL-16**

### **Addition of simple agc circuit.**

A simple agc circuit may be added to the VL-16 chassis without agc by following the procedure given below:

1. Re-dress the .1- $\mu$ f, 600-volt audio decoupling capacitor (*C93*).

2. Re-dress the .05- $\mu$ f, 400-volt video coupling capacitor (*C35*).

3. Mount a 4-terminal strip in fifth ventilating hole from rear apron over video-detector socket.

4. Remove one end of the 4,700-ohms, 1/2-watt video-detector load resistor (*R23*) from ground and connect to No. 1 terminal of terminal strip.

5. Remove black wire of *T5* (*SA-334* transformer) from ground and connect to terminal No. 1 of terminal strip. Splice additional length of wire, if necessary.

6. Connect .005- $\mu$ f disc capacitor (*HCC-1926*) from terminal 1 on terminal strip to the ground terminal from which video detector diode load resistor was removed above.

7. Remove 100,000-ohm, 1/2-watt resistor (*R64*) and 33,000-ohm resistor (*R93*) from arm of contrast control. Remove other ends of these resistors from their tie points, leaving other components and wires attached to the tie points.

8. Connect wire from arm of contrast control, routing this wire along

same path as white wire going to *Metro-Fringe* switch on rear apron. Follow rear apron of chassis. Continue and connect to terminal No. 1 of terminal strip which was installed as above.

9. Connect a jumper from the junction of video-detector load resistor and peaking coil *L8* to terminal No. 2 on terminal strip installed. (*L8* is a green-dot peaking coil.)

10. Connect 33,000-ohm resistor (*R93*) removed in step 7 between pin 7 on delay diode *6AL5* and terminal No. 2 on terminal strip installed previously.

11. Connect 100,000-ohm resistor (*R64*) removed in step 7 between terminals No. 2 and No. 4 on terminal strip.

12. Connect a 1-foot piece of wire from video i-f bias point (terminal No. 3 of terminal strip located directly below *V4* and *V5*, first and second video i-f tubes) to terminal No. 4 on terminal strip installed previously. This wire is to be dressed against chassis following route of brown and orange wires to rear apron.

**ANDREA** Chassis VL-16  
**Line fuse insertion.**

Early VL-16 chassis do not have a line fuse. It is advisable to insert a line fuse on all VL-16 chassis that come into the shop.

If it is found difficult to mount a fuse holder on the chassis itself, a fused plug may be used. In all cases, the fuse should not be any larger than a 5-ampere, 250-volt type 3AG.

**ANDREA** Chassis VL-16  
**Preventing arcing and burning**  
(see Fig. 8).

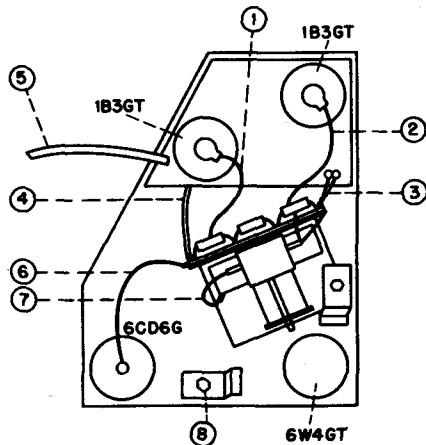

Fig. 8 — Andrea

Whenever any work must be done in the high-voltage compartment or if a tube is replaced in this section, proper lead dress must be maintained. Extreme care must be used to prevent connecting wires to the tube caps from touching any portion of the metal compartment or other components. Failure to observe this precaution may cause arcing and burning.

Wires 1, 2, 5, 6, and 7 shown in the figure must be kept in the clear. They must not rest on other components or on the sides of the compartment. Whenever parts are replaced, make these wires short and direct but do not put a strain on the parts. Wires 3 and 4 must not be pulled too tightly. Be sure to round off soldering connections on any work done. Also, do not turn the width coil slug (part 8 in the figure) out too far, thereby lowering the impedance, as this may cause the coil to overheat or even burn.



## ARVIN

Chassis TE-272

### Poor interlace.

It has been found that horizontal pulses, coupled into the envelope of *V13* by the red horizontal lead from the high-voltage compartment going to socket *S102* being too close to *V13*, prevent good interlace. Dressing the lead down to the chassis as close as possible and wedging it away from *V13* will aid the condition of good interlace. Future production receivers will have a shield on *V13*.

## ARVIN

Chassis TE-272

### Regeneration in sound strip.

In some chassis the blue lead from pin 5 and 6 of *V4* to the junction of *R158* and *R159* runs around the socket and input circuit of *V6*, in some cases causing regeneration. The lead is now being rerouted (down close to the chassis) so that it runs between *V5* and *T109* and between *V8* and *T107* to the junction of *R158* and *R159*.

The shield can of the discriminator transformer, *T102*, should have its mounting nuts holding the can down very tightly. Leakage radiation from the bottom of the can could cause regeneration. Tightening of the mounting nuts in most cases will eliminate this particular cause of regeneration.

## ARVIN

Chassis TE-272-1,  
TE-272-2, TE-276

### Wide vertical black bar.

The condition of one wide vertical black bar dividing the picture in half with the normal right side of the picture appearing on the left, and the left side on the right, can be caused by *C167* developing a high resistance short of 3 to 4 megohms.

The fault could prove to be difficult to find since normally the logical location of such a horizontal-sync trouble would be in the horizontal oscillator and control circuit of *V16*. *C167* connects between pin 2 of *V10A* and pin 2 of *V14A*.

## ARVIN

Chassis TE-272-1,  
TE-272-2, TE-276

### Audio buzz at minimum volume setting (see Fig. 9).

In later models, the vertical-output transformer, *T111*, was changed to an autotransformer having three leads instead of four. If *C178* is left with one side hooked to ground, vertical buzz will be present in the speaker. In those receivers in which this fault exists, *C178* should be connected to the junction of *R200* and *C177C* instead of ground. This is shown in the figure.

Two other possible sources of audio buzz are as follows:

1. The white and orange lead from pin 8 of *V11B*, the video amplifier, being too loose and dressed close to the volume-control terminals. Redress this lead.

2. *C121C*, 80  $\mu$ f, having an undesirable power factor or being leaky. Replace such a capacitor.



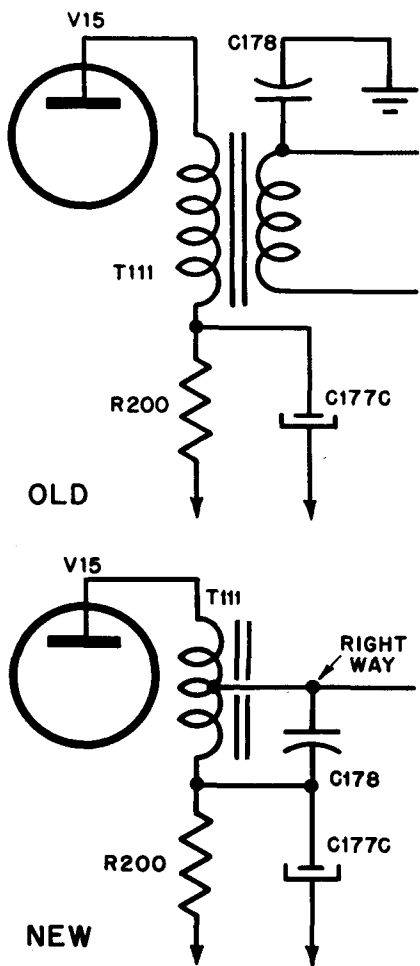

Fig. 9 — Arvin

**ARVIN** Chassis TE-272-1,  
TE-272-2, TE-276

**Audio buzz on strong signals.**

In some locations of strong signal strength, vertical buzz is present in the audio which can be tuned to a minimum by the fine-tuning control when tuned carefully for best sound reception. The follow-

ing change can be made very easily in the field for reducing this buzz in strong signal areas: Change R157 (-2) from 120,000 to 75,000 ohms.

R157(-2) connects to pin 5 of V12 and is accessible when the bottom cabinet cover is removed. Soldering a 200,000-ohm resistor in parallel with the 120,000-ohm unit will be the same as replacing it with a 75,000-ohm resistor, and is probably easier.

**ARVIN** Chassis TE-272-1,  
TE-272-2, TE-276  
**White horizontal bar at top of raster and critical vertical sync.**

It has been noted that some of the T110, vertical-oscillator transformers, used in production since January 1, 1950 develop a parasitic which superimposes an added spike of voltage onto the return sweep part of the vertical-sweep waveform. This results in a bunching of retrace lines about 1-inch from the top of the picture, causing an accentuated white horizontal portion which can be seen readily when the brightness is increased.

A 2.2-megohm damping resistor across the primary of T110 (between the green and yellow leads) is being added in production to forestall any such parasitic developing.

The parasitic in some cases results also in very touchy vertical sync.

**ARVIN** Chassis TE-286  
**Reduction of video ringing and improved noise immunity.**

The following changes may be made to reduce video ringing and to

increase the impulse-type noise immunity of the receiver:

1. *L109* and *R126* connect to pin 8 of *V12*, video-output tube. A 10,000-ohm, 1/2-watt resistor is connected in parallel with *L109* and *R126*. This reduces the high-frequency peaking in the video-output stage and eliminates excessive ringing which appears as white shadow following black in the picture.

2. *R160* (22,000 ohms) connects to pin 2 of *V13*, 6AV6, agc cathode-follower. A .1- $\mu$ f, 200-volt capacitor is connected in parallel with *R160* to effectively increase the time constant to make the circuit more immune to impulse-type noises. With the original shorter time constant, fast impulse-type noises caused white streaks in the picture. The increased time constant is very effective in reducing these white streaks.

#### **ARVIN**                      **Chassis TE-289-2** **Reducing snow.**

Broadly speaking, it can be said that there are three areas of reception: the prime-signal area of metropolitan areas, the secondary-signal area outside metropolitan areas, and the fringe area. In the secondary-signal area, the agc voltage developed on the r-f grid will sometimes prevent the receiver from operating at maximum necessary gain and, therefore, the snow content appearing in the picture may seem excessive. By removing the agc voltage applied to the r-f grid, the snow content in the picture may be reduced.

As indicated on the schematic diagram, a white agc lead comes from the tuner unit and connects to the

junction of *R147* and *C148*. This junction point is made on a terminal strip on the chassis near the socket of *V4*. This junction point supplies the agc voltage to the r-f grid. If this end of the white lead is clipped free from the junction point of *R147* and *C148* and then soldered to a clear spot on the chassis (ground) nearby, the reduction of snow content in the picture will be apparent in many cases.

When the agc voltage is removed from the r-f grid in this manner, it must be remembered that the receiver could overload if taken into a strong-signal area. Therefore, if it would become necessary to operate the receiver on the strong signals, the white lead would again have to be connected to the agc junction point.

For fringe-area reception, no difference will be noticed with the lead grounded or connected to the agc point, because in fringe areas there would be insufficient signal to develop any agc and no agc voltage to remove.

#### **ARVIN**                      **Chassis TE-289-3,** **TE-290-2, TE-290-3**

#### **Increasing sound sensitivity and reducing overmodulation buzz.**

In some areas where signal strength is low or the station sometimes tends to overmodulate, it may be desirable to increase sound sensitivity of the deluxe chassis which have the 4.5-mc trap in the video amplifier plate circuit. This can be done by reversing the connections on the trap. There is a certain amount of inductive coupling between *L101*

(sound take-off) and *L120* (4.5-mc trap). Reversing the connections on the trap will cause the stray field of the trap to be additive with the sound take-off coil. This change under extreme conditions will increase sound and will reduce buzz due to station overmodulation.

The trap should be realigned after the connections are reversed. Connect a 4.5-mc signal (crystal calibrated) to pin 4 of the video amplifier and a VTVM to pin 7 of the ratio detector (*V2*), 6AL5. Adjust the 4.5-mc trap for maximum meter deflection. If a calibrated test signal isn't available, tune in any available television station and adjust both *L120* and *L101* for maximum meter deflection.

#### ARVIN

Chassis TE-289-3,  
TE-290

#### Improving channel 7 sensitivity.

Because of the close proximity of the 300-ohm lead-in to the i-f strip on deluxe chassis, a harmonic of the i.f. is coupled into the lead, causing the picture to appear snowy on channel 7. This situation can be improved as follows:

Use a lead about 8 inches longer and reroute it as far away from the i-f strip as possible, not using the lead-in standoff which is on the chassis. A convenient method is to staple or tack the lead to the side of the cabinet.

#### ARVIN

Chassis TE-289-3

#### Intercarrier buzz reduction (see Fig. 10).

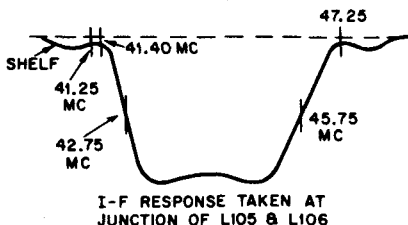

Fig. 10 — Arvin

1. Check buzz due to intermodulation within the sync and audio tube, *V19*, by pulling out *V1*, 6AU6. Change *V19* if buzz is still audible.

2. It is normal to have buzz at maximum contrast control setting due to nonlinear operation of the video amplifier, *V8*, at minimum bias. At normal contrast settings this type of buzz will not occur.

3. Dynamic unbalance of the ratio detector secondary, *T101*, can emphasize buzz due to incomplete amplitude rejection. *R104* should be checked to be 82 ohms, to improve the balance, and not 47 ohms as in early production receivers. On a received test pattern a slight readjustment of *T101* secondary, top, can be made to obtain the buzz dip point. With the contrast-control setting reduced for strong signals, a slight touch-up of *L101* may also reduce buzz amplitude. It is important before touch-up of *L101* and *T101* that the station be tuned in as follows:

Turn the *station tuning control* slowly clockwise until the picture begins to break-up. Then turn the control slowly counter-clockwise — tuning for best picture definition. *T101* and *L101* should be touched-up only for this tuning point.

4. Check video i-f alignment so that the 41.25-mc sound carrier falls

properly on the sound-porch and overall response is correct (see illustration).

5. Check for defective peaking coils in the video-amplifier circuit, mainly *L106* and *L103*.

6. Check *C108*, ratio detector bypass. Also, check B-supply electrolytic filter capacitors which, if defective, could allow vertical pulses from the vertical oscillator to couple into the audio.

7. Check lead and component dress in the sync and audio circuits.

#### **ARVIN** Chassis TE-290 **Intercarrier buzz reduction.**

Slight dynamic unbalance of the ratio detector secondary, *T101*, can emphasize intercarrier buzz due to incomplete amplitude-modulation rejection. Therefore, it is vitally important to obtain an accurate setting of the discriminator secondary slug under actual reception conditions. Disconnect all instruments and then connect an antenna to the receiver to obtain program reception from a local station. If intercarrier buzz is prominent, a slight readjustment of the ratio-detector secondary, top, slug should be made to obtain the buzz dip point. Slight touch-up of *L101*, top, may also affect buzz amplitude. If intercarrier buzz still persists, check the circuit components around *V3B* and *V3A*. Coupling between components in the sync and audio can be reduced by movement of the components. Tube 12AU7, *V3*, sometimes has intermodulation within the tube envelope and should be checked by changing with a new 12AU7.

#### **ARVIN** Chassis TE-290 **Slippage of channel-switch shaft.**

Slippage of the channel-switch shaft where the cam is attached to the shaft results in inability to switch bands.

This has been corrected in production and the new part is available, if needed, by ordering the following part by description from the manufacturer: AC24223-2; tuning shaft, cam and bracket assembly.

#### **ARVIN** Chassis TE-290 **Raster ringing.**

Variations in the capacitance of the upper winding of the horizontal-deflection coils to ground in the AC23816-2 yoke appear as a wiggle-waggle and ringing effect. This effect usually appears as two or three light vertical bars caused by wavy raster lines in the left portion of the picture.

A compensating capacitor, *C162*, is used to correct for these variations. The variations of the AC23816-2 yoke could not be corrected with one value of fixed capacitance, therefore different values have been used in production. Receivers were produced with *C162* equal to 22, 27, 33, 39, and 47  $\mu\mu\text{f}$ .

It may be necessary to change the value of *C162* to one of the above mentioned values if this ringing effect appears objectionable. This capacitor is easily accessible by removing the focalizer unit mounting plate and the plastic cover on the rear of the deflection yoke.

Part No. AC24292 yoke assembly is also used on the TE-290 chassis; one value of *C162*, 47  $\mu\mu\text{f}$ , corrects for this capacitance of the upper windings to ground.

**ARVIN** Chassis TE-290

**Reduction of snow.**

On some 16-inch deluxe chassis the ground lead to the metal shell of the 6AC7 radiates so that pictures appear snowy and are unstable in weak signal areas. Normally, the shield is grounded to a grounding lug with a lead approximately 1 inch long. This lead should be shortened and soldered directly to the chassis below pin 1, making the lead as short as possible. This will reduce the radiation, thus improving the performance of the set in weak signal areas.

**ARVIN** Chassis TE-290-2

**Improving vertical stability.**

Vertical stability may be improved under impulse-noise conditions by adding a 10,000-ohm resistor in series with the lead that connects to the junction of *R117* and *R118* (in plate circuit of video amplifier). This resistor acts as a noise suppressor that is most effective under weak signal conditions in the presence of impulse-type noises.

**ARVIN** Chassis TE-300,  
TE-302, TE-315

**Improving vertical stability.**

Vertical stability can be improved on 17-, 20-, and 21-inch custom sets in low-signal areas by changing the input circuit of the vertical oscillator. Remove *C202* and *R180* and replace them with a 2-megohm resistor. In some cases this will reduce interlace slightly but will possibly improve vertical stability.

In extremely noisy locations, stability can be improved by increasing

the time constant of the agc. This is done by adding a .5- $\mu$ f capacitor in parallel with *C159*, which is located in the grid circuit of *V13* (the agc cathode-follower). This will cause the agc to operate more slowly and thus be affected less by noise. The change will reduce performance during airplane flutter but will improve stability in high noise locations.

**ARVIN** Chassis TE-300,  
TE-315

**Improvement of sound noise rejection.**

The noise-rejection characteristics of the sound section of the custom chassis may be improved in fringe areas by touch-up alignment of the sound i-f strip. This can be done on the station signal. The only equipment necessary is a vacuum-tube voltmeter or a 20,000 ohms-per-volt voltmeter. (Use a 27,000-ohm isolating resistor on the end of voltmeter lead.)

The station should be correctly tuned in and voltmeter connected across *R107*, which is in the grid circuit of the limiter (*V3*). Adjust top of *L101*, top and bottom of *T101*, and *L108* for maximum meter deflection.

With voltmeter connected to the junction of *R111* and *R112* (in the cathode circuit of discriminator, *V4*), adjust bottom of *T102* for maximum. Connect voltmeter to junction of *R112* and *R113* and adjust top of *T102* for zero reading on voltmeter. This adjustment can also be made by adjusting top of *T102* for minimum noise in the sound.

The two adjustments on *T102* are very delicate and will rarely require more than  $\frac{1}{4}$  turn for proper adjustment.

Because of the high sound sensitivity of this set, it can be slightly out of alignment and there still will be ample amount of sound. However, by correct alignment there will be more limiting done by the limiter and consequently better noise rejection.

**ARVIN** Chassis TE-300,  
TE-315

**Improving vertical stability.**

The vertical stability can be improved on custom chassis on which the vertical hold control is near the end of its range. *R181*, which is in series with the *vertical hold control*, should be reduced in value so that the set holds sync with the control near the center of its range. On the 20-inch and 21-inch sets *R181* should be replaced with a resistor value between 1.2 and 1.6 megohms. This will increase the usable range of the vertical hold and thus improve the vertical stability of the set.

**ARVIN** Chassis TE-300,  
TE-315

**Reducing whistle in sound.**

In custom receivers where a high-frequency whistle or tweet (audio hash) is present in the sound, the alignment of the audio section should be checked.

Also, the tweet can be reduced further by putting a  $.1\text{-}\mu\text{f}$  capacitor from pin 3 of the video amplifier

(*V12*) to ground and a  $.005\text{-}\mu\text{f}$  capacitor from pin 7 of AGC tube (*V14*) to ground.

**ARVIN** Chassis TE-302-2,  
TE-315-1

**Increasing range of horizontal-hold control.**

*R210*, a 22,000-ohm resistor which shunts the horizontal-hold control, is changed to 47,000 ohms. This change increases the range of the horizontal-hold control and minimizes the chances of the oscillator drifting beyond the range of the front panel control.

**ARVIN** Chassis TE-302-2,  
TE-315-1

**Greater sound quieting and gain.**

*C204*, a  $5\text{-}\mu\text{f}$  capacitor connected between the grid of the first video i-f stage and ground, is changed to  $8.2\ \mu\text{f}$  resulting in greater sound gain and better quieting at the discriminator. This also changes the tuning of the top slug of *T104*. With the change, the slug position will be higher and decrease the coupling to the trap winding. In making this change, *T104* should be tuned using a television sweep generator, following the instructions given in the service notes on i-f alignment.

**ARVIN** Chassis TE-302-2,  
TE-315-1

**Squeal in sound.**

*C206*, a  $5,000\text{-}\mu\text{f}$  disc capacitor is added from pin 7 of *V14* (AGC tube) to ground to eliminate a tweet or squeal in the sound.

**ARVIN**Chassis TE-302-3,  
TE-315-2**Eliminating i-f interference.**

I-f trap C25255 is added. This trap is mounted just back of the tuner unit on the chassis. The antenna lead is cut about 4 inches from the tuner. The cut ends are connected to the four terminals of the trap. This trap is to eliminate r-f interference below 45 mc. This trap actually is a high-pass filter.

**ARVIN**Chassis TE-302-4,  
TE-315-3**Squeal in sound.**

C206, 5,000- $\mu$ mf disc capacitor from pin 7 of V14 to ground, is removed. R230, 1,500-ohm,  $\frac{1}{2}$ -watt, 20% resistor, is added in series with the -12 volt lead feeding the 6AC7 suppressor grid and control grid. This is done by moving the -12 volt leads from pin 3 of the 6AC7, and tying them to pin 7 (unused) of the 5U4 socket, then connecting the 1,500-ohm resistor from pin 7 of the 5U4 socket to pin 3 of the 6AC7.

A .1- $\mu$ f 200-volt, 20% capacitor is added, across the 50-ohm resistor from ground to -12 volt, from pin 5 of V23 to ground.

The ground lead from the 3,000- $\mu$ f electrolytic capacitor is moved from its present location to a ground lug on the electrolytic mounted on the main chassis front flange.

The -12 volt lead from pin 7 of the 5U4 socket is rerouted away from the rear of the chassis and also tied to the terminal strip from the opposite side, away from the damper-tube wiring.

**ARVIN**Chassis TE-302-5,  
TE-315-4**Vertical retrace blanking.**

The B+ is removed from the red lead of the vertical-output choke and tied to the green lead or center-tap of the output choke (L111, output circuit of V17 vertical-output tube).

C208, .022- $\mu$ f, 200-volt capacitor is connected across the green and red leads (output section) of the vertical-output choke.

R231, 220,000-ohm,  $\frac{1}{2}$ -watt resistor is connected between the grid (pin 2) of the picture tube and the junction of R135 brightness control and C128.

C210, .1- $\mu$ f, 1000-volts and C209, .1- $\mu$ f, 400-volts are connected in series. Then, C209 is connected to the grid of the picture tube and C210 is connected to the red lead of the vertical choke. A resistor, R232, 8,200 ohms,  $\frac{1}{2}$ -watt is connected from the junction of C210 and C209 to ground.

These circuit changes blank the picture tube during the vertical-retrace time. The white diagonal lines normally seen when the picture is dim or completely absent will not be visible.

**ARVIN**

Chassis TE-389

**Increasing life of V12, 6AV5GT***(see Fig. 11).*

The life of V12 can be increased by making this change:

1. R186 850-ohm, 10-watt resistor added between cathode and ground of 6AV5GT tube.
2. Ground side of C166 capacitor rerouted to cathode of 6AV5GT.

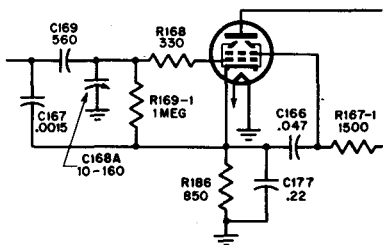

Fig. 11 — Arvin

3. *C177*, .22- $\mu$ f, 400-volt capacitor added to cathode circuit of 6AV5GT tube.

4. *R167* resistor changed to *R167-1*, 1,500-ohm, 10-watt resistor.

5. Ground side of *C167* (.0015  $\mu$ f) capacitor rerouted to 6AV5GT cathode.

6. *R169-1* (1 megohm) resistor ground side rerouted to 6AV5GT cathode.

#### ARVIN 12½-inch Chassis Increasing range of focus control.

Some 12½-inch receivers may exhibit lack of sufficient range of the *focus control* to focus the raster properly. A component change is being executed in production to eliminate this possibility in the future. Any 12½-inch set in the field can have this fault corrected quickly and easily by the following procedure without pulling the chassis from the cabinet:

1. Remove the bottom cabinet cover, exposing a major portion of the chassis wiring.

2. On the front-side flange of the chassis two terminal strips are mounted in line. One of these strips has on its end terminal a 330-ohm, 2-watt, and a 100-ohm, ½-watt re-

sistor tied to it. Also, two red wires join on this terminal.

3. Connect one side of an 1,800-ohm, 2-watt, 10% resistor to this terminal.

4. Viewing the chassis from the bottom, one can see another terminal strip (6 terminals) mounted on the main chassis below the above two which are on the front flange.

5. A green lead coming from the focus coil connects to a terminal beside the ground lug of the terminal strip.

6. Connect the other end of the 1,800-ohm resistor to this point.

This 1,800-ohm, 2-watt, shunt resistor across the focus coil will improve the range of the *focus control* satisfactorily.

#### ARVIN 12½-inch Chassis Breakdown of capacitors shunting width coil.

Early production of the 12½-inch chassis utilized two 270- $\mu$ f capacitors in series across terminals 4 and 6 of *T113*, the horizontal-output transformer. These capacitors allow greater scan and necessary picture width for the 12½-inch picture tube. Breakdown of these capacitors, resulting in a short across terminals 4 and 6, will show up as follows:

1. No high voltage, therefore no raster.

2. More frequently there will still be some high voltage, but no horizontal scan. Only a narrow vertical white trace displaced to the right will appear on the picture tube.

Present production is using a .047- $\mu$ f, 200-volt, molded, oil-filled capacitor across the width control,



L115, instead of the two 270- $\mu\text{f}$  capacitors across terminals 4 and 6 of T113. This change is recommended whenever the above breakdown trouble occurs and also on any early production 12 $\frac{1}{2}$ -inch model brought in for service, to forestall future trouble of this nature. The best connection for the .047- $\mu\text{f}$  capacitor is between terminal 6 of T113 and the switch terminal of SW102, that connects to terminal 5 of T113.



**BELMONT-RAYTHEON**

Chassis 7DX22-P

**Improved horizontal and vertical linearity (see Fig. 12).**

The manufacturer supplies modification kit H which is used to improve the horizontal and vertical

linearity. The wiring instructions used with this kit are as follows:

1. Remove the vertical multivibrator and the output tubes (tubes 14 and 15 both 12SN7).
2. Place the template supplied with the kit over the tube sockets.
3. Center punch and drill two  $\frac{3}{8}$ -inch holes after pushing away the wires under the chassis to prevent damage.
4. Mount the two controls with the hardware provided.
5. Remove resistor R72 and capacitor C95 between pin 8 of tube 13 and B—, and connect pin 8 to B—.
6. Connect capacitor C95 from one end terminal of the vertical-linearity control to pin 5 of tube 14.
7. Connect the other end terminal of the vertical linearity control to B—.
8. Remove the connection of resistor R97 (6.8 megohm) to pin 5 of tube 14. Replace the 6.8-megohm re-

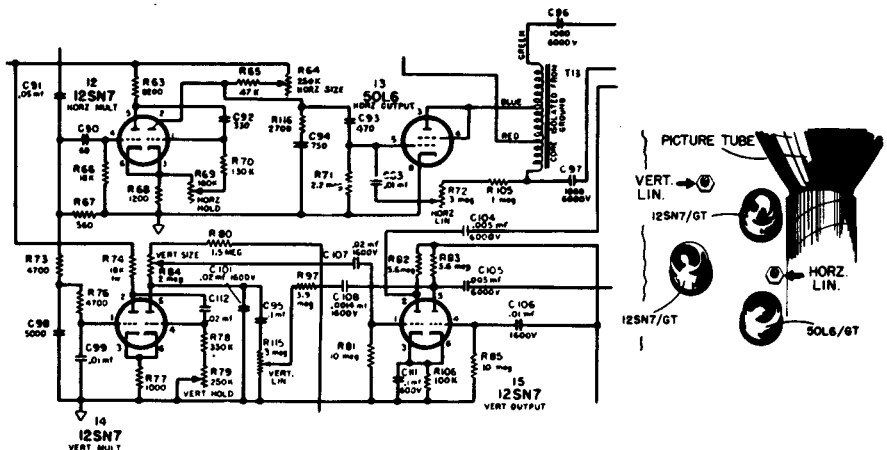

Fig. 12 — Belmont-Raytheon

## PARTS LIST

Ref. No.	Part No.	Description
R70	C-9B1-210	130k ohms, 1/2 watt, 5%
R72	A-10B-17318	Horizontal Linearity, (3 megohms)
R78	C-9B1-92	330k ohms, 1/2 watt, 10%
R97	C-9B1-105	3.9 megohms, 1/2 watt, 10%
R105	C-9B1-98	1 megohm, 1/2 watt, 10%
R115	A-10B-17318	Vertical Linearity, (3 megohms)
R116	C-9B1-67	2,700 ohms, 1/2 watt, 10%

sistor with a 3.9-megohm resistor. Connect the loose end of *R97* to the center-tap of the vertical-linearity control.

9. Remove capacitor *C120* (800- $\mu$ f — 1,600 volts).

10. Change resistor *R78* from 390,000 ohms to 330,000 ohms.

11. Change resistor *R70* from 100,000 to 130,000 ohms.

12. Connect a 2,700-ohm resistor (*R116*) between pin 2 of tube 12 and capacitor *C94* (750  $\mu$ f).

13. Remove the connection between the .01- $\mu$ f capacitor (*C83*) and the 3.3-megohm resistor (*R105*) on the terminal board.

14. Connect capacitor *C83* to the center-tap of the horizontal-linearity control (*R72*).

15. Change resistor *R105* from 3.3 megohms to 1 megohm.

16. Connect a wire from the end of resistor *R105* to one of the two unused terminals on the horizontal-linearity control.

Note: If echoes, (similar to ghosts) are noticed in the picture, a simple wiring change can eliminate this condition. Remove the wire connection from pin 2 of the 12AU6 (video amplifier) to the contrast control. Connect pin 2 directly to B—.

### BELMONT-RAYTHEON

Chassis 10DX21,  
10DX22, 10DX24, and  
10AXF43, Seres A, (No-  
Code or Code B)

#### **Stabilized horizontal multivibrator and reduction of picture shift (see Fig. 13).**

The manufacturer supplies modification kit EF to correct the above effects. Since many television broadcasting stations have the practice of locking their sync directly to the 60-cycle line, any phase shift in the transmitter power source may cause side-to-side picture drift. The changes incorporated in this modification reduce the tendency toward picture drift and improve the picture resolution in low-signal areas by providing a flywheel stabilization effect in the horizontal multivibrator.

The wiring changes are primarily located on the sockets of *V11* and *V12* and on the terminal board between the two sockets. They consist mainly of substituting one value of resistor or capacitor for another. For simplicity follow in sequence the wiring instructions below:

1. Change 1,800-ohm resistor on terminal board supplied with modification kit to 3,300 ohms.

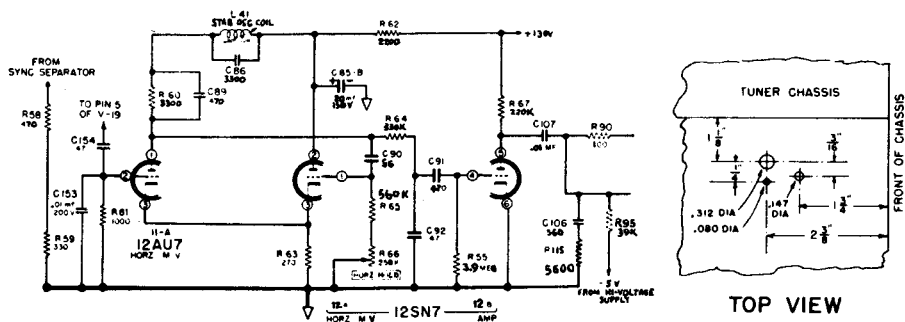

Fig. 13 — Belmont-Raytheon

2. Remove 470  $\mu\text{f}$  ( $C89$ ) (pin 2 of  $V11$ ) from chassis, and rewire across 3,300-ohm resistor on terminal board supplied with kit.
3. Remove 33,000-ohm resistor ( $R60$ ) connected from pin 1 of  $V11$  to pin 2 of  $V12$ .
4. Change  $R64$  (pin 1 of  $V11$ ) to 330,000 ohms.
5. Change  $C92$  (pin 6 of  $V12$ ) to 47  $\mu\text{f}$ .
6. Connect blue wire to pin 1 of  $V11$ .

7. Connect red wire to pin 2 of  $V12$ . (The red and blue wires should be a twisted pair and take the same path as the yellow and green wires already in place.)
8. Change  $R67$  (pin 5 of  $V12$ ) to 220,000 ohms.
9. Change  $R95$  (terminal No. 2 on terminal board adjacent to the center 50B5 socket) to 39,000 ohms.
10. Add 560  $\mu\text{f}$ , ( $C106$ ) from terminal No. 2 on terminal board adjacent to the center 50B5 socket to pin 4 of the ballast tube.

## PARTS LIST

Ref. No.	Part No.	Description
L41	A-13D-16943	Coil
	A-51A-16945	Iron core for coil $L41$
R64	C-9B1-92	Resistor, 330k ohms, $\frac{1}{2}$ watt, $\pm 10\%$
R67	C-9B1-27	Resistor, 220k ohms, $\frac{1}{2}$ watt, $\pm 10\%$
R60	C-9B1-68	Resistor, 3.3k ohms, $\frac{1}{2}$ watt, $\pm 10\%$
R61	C-9B1-13	Resistor, 1000 ohms, $\frac{1}{2}$ watt, $\pm 10\%$
R59	C-9B1-56	Resistor, 330 ohms, $\frac{1}{2}$ watt, $\pm 10\%$
R95	C-9B1-81	39k ohms, $\frac{1}{2}$ watt, $\pm 10\%$
R115	C-9B1-71	5,600 ohms, $\frac{1}{2}$ watt, $\pm 10\%$
C153	C-8D-16669	Capacitor, .01 $\mu\text{f}$ , 200 volts
C86	C-8F8-131	Capacitor, 3,300 $\mu\text{f}$ , $\pm 10\%$
C89	C-8F3-121	Capacitor, 470 $\mu\text{f}$ , $\pm 10\%$
C106	C-8F3-122	560 $\mu\text{f}$ , $\pm 10\%$
C92, 154	C-8F3-109	Capacitor, 47 $\mu\text{f}$ , $\pm 10\%$

11. Add 5,600 ohms (*R115*) from pin 4 of the balist tube to center tap of the vertical-linearity control.

12. Change *R59* (pin 6 of *V12*) to 330 ohms.

13. Change *R61* (pin 2 of *V11*) to 1,000 ohms.

14. Add .01  $\mu\text{f}$  at 200 volts (*C153*) across 1,000 ohm (*R61*).

15. Add 47  $\mu\text{f}$  (*C154*) from pin 2 of *V11* to pin 5 of *V19*.

Some of the first chassis made do not have the mounting holes for the oscillator coil and the terminal board that has to be added. These holes are located at the front of the chassis near the opening for the tuner. It is suggested that the coil and terminal board be mounted before any wiring is done.

## BELMONT-RAYTHEON

Chassis 10DX21,  
10DX22, 10DX24, and  
10AXF43, Series A  
(Code C or D), Series  
B (No-Code and Code  
51)

### Reduction of picture shift.

Due to the practice of many television broadcasting stations of locking their sync directly to the 60-cycle power line, some sets may exhibit a tendency toward side-to-side picture drift. This is caused by phase shift in the transmitter power source.

The manufacturer supplies modification kit F to correct the above effect. The wiring instructions are as follows:

1. Remove *C89* (470  $\mu\text{f}$ ) from pin 2 of *V11* (horizontal multivibrator).

2. Change *R60* from pin 1 of *V11* to 3,300 ohms (C-9B1-68).

3. Add 470  $\mu\text{f}$  (C-8F3-121) across 3,300 ohms or *R60*.

4. Change *R61* from pin 2 of *V11* to 1,000 ohms (C-9B1-13).

5. Add .01  $\mu\text{f}$ , 200 volts (C-8D-16669) across 1,000 ohms or *R61*.

6. Add 47  $\mu\text{f}$  (C-8F3-109) from pin 2 of *V11* to pin 5 of *V19*.

## BELMONT-RAYTHEON

Chassis 14AX21

### Apparent yoke failure.

Apparent yoke failures evidenced by a reduction in over-all width and a trapazoiding effect (width at bottom less than that at top) may be caused by a defective 47- $\mu\text{f}$  capacitor (*C-126*) wired internally in the yoke. The 47- $\mu\text{f}$  capacitor (*C-126*) is of the uninsulated ceramic type; due to incorrect lead dress it may cause a shorting condition. Before the yoke is replaced the 47- $\mu\text{f}$  capacitor should be checked. If the capacitor is shorted it should be replaced and the yoke can be used again.

If this trapazoiding condition is noticed, the yoke can be removed without pulling the chassis from the cabinet. First remove the cabinet back, then the picture-tube socket, ion trap, focus magnet, wing nut, yoke plug and then the yoke.

## BELMONT-RAYTHEON

Chassis 14AX21

### Tuner contact replacement.

As stated in the 14AX21 service notes, the tuner must be removed from the chassis when contact replacement is necessary. A mechanical change was made in the tuner to

permit contact replacement without removing the tuner from the chassis. To replace contacts in the new revised tuner, simply remove the two switch plate tension springs, remove the hex head bolt and switch lever bracket, lift up switch lever and replace contacts.

#### **BELMONT-RAYTHEON**

Chassis 16AY28,  
16AY211, 17AY24, 17AY27,  
20AY21

##### **Replacement of yoke.**

The deflection yoke is a complete assembly and includes capacitor *C-126* (47  $\mu\text{mf}$ ), resistors *R-125*, *R-126* (1,000 ohms,  $\frac{1}{2}$  watt) and the yoke leads and plug. The deflection yoke can be replaced without soldering the necessary component parts and leads.

#### **BELMONT-RAYTHEON**

Chassis 16AY28,  
16AY211, 17AY24, 17AY27,  
20AY21

##### **High-voltage supply lead dress.**

In the process of inspection, repairs, changing of tubes or transformers, or for any other reason when it is necessary to work within the high-voltage power supply, the following should be closely observed.

1. Terminals on the 1X2 socket must be dressed toward the inside of the corona ring and be free of sharp protrusions.

2. The corona ring must be dressed in such a way as to make its presence useful; that is, properly centered and about  $\frac{1}{8}$ -inch below the socket terminals.

3. All leads must be dressed as far away as possible from the transformer winding. Excess lead length should be transferred to the underside of the chassis.

When replacing a horizontal-deflection transformer, be sure to follow the precautions listed above closely. The transformer can be replaced as a complete assembly; that is, with capacitor *C-127* and resistor *R-132*.

#### **BELMONT-RAYTHEON**

Chassis 16AY28,  
16AY211, 17AY21, 17AY24

##### **Horizontal nonlinearity.**

Horizontal nonlinearity, left-hand bulge, stretched or egg-shaped test patterns can in most cases be eliminated by proper adjustment of the rear controls. Refer to service notes and follow the adjustment procedure prescribed.

If the above adjustment procedure does not produce satisfactory results, the following modification should be incorporated to remedy any receiver with horizontal nonlinearity.

1. Replace .05- $\mu\text{f}$  capacitor (*C-106*) across the horizontal-linearity coil with a .02- $\mu\text{f}$  capacitor (8D-17268).

2. Connect a jumper wire across the 10-ohm resistor (*R-95*) on the horizontal-linearity coil.

3. Replace linearity-coil core with the same type core as in the horizontal size coil (51A-16945).

4. Connect a 10,000-ohm, 1-watt resistor (9B2-74) in parallel with the 20- $\mu\text{f}$  x 150-volt, boost electrolytic (*C-115*).

5. Replace 470- $\mu\text{f}$  mica capacitor (C-135) across horizontal-drive trimmer with an 820- $\mu\text{f}$  capacitor (8F6-124).

6. Connect a .15- $\mu\text{f}$  capacitor (8D-15667) in series with the low side of the horizontal-yoke winding.

a. 16AY28 and 17AY21 Chassis: Remove three red leads and 220,000-ohm resistor from pin 1 of yoke socket and connect to pin 4 of damper socket. Connect .15- $\mu\text{f}$  capacitor between pin 1 of yoke socket and pin 4 of damper socket.

b. 16AY211 and 17AY24 Chassis: Remove jumper wire from pin 1 to pin 4 of yoke socket. Connect .15- $\mu\text{f}$  capacitor between pin 1 and pin 4 of yoke socket.

7. Follow adjustment procedure below:

a. Adjustments should be made with a test pattern.

b. Adjust *Horizontal Size* control until entire screen is filled horizontally.

c. Turn *Horizontal Drive* control clockwise until trimmer is tight.

d. Set *Horizontal Linearity* control to left end of slot (toward vertical controls).

e. Turn *Horizontal Drive* control counterclockwise until left-half circle is approximately  $\frac{1}{4}$  inch shorter than right-half circle.

f. Adjust *Horizontal Linearity* control for proper linearity.

g. If adjustment of *Horizontal Linearity* control produces drive bars turn *H. Drive* control slightly clockwise.

## BELMONT-RAYTHEON

Chassis 16AY28,  
17AY21

### **Preventing squegging.**

Squegging is a condition evidenced by white lines or streaks running diagonally across the picture and a singing in the speaker when tuning from one station to another. Squegging may be eliminated in the majority of cases by properly adjusting the horizontal-drive control. If this condition is not eliminated by adjustment of the drive control, two resistors in the afc circuit should be changed in value. Resistor R-82 (470,000 ohms) should be changed to 1 megohm (C-9B1-98) and resistor R-87 (330,000 ohms) changed to 680,000 ohms (C-9B1-96).

## BELMONT-RAYTHEON

Chassis 17AY27

### **Checking and replacing crystal detector (CK-706).**

To check a suspected defective germanium crystal detector, place the selector switch in either the TV or PH position and connect the leads of an ohmmeter across the crystal.

The backward resistance should be 300,000 ohms or more and the forward resistance should be approximately 200 ohms.

Extreme caution should be observed when working with a soldering iron near the crystal. Heat may permanently damage it.

If replacement is necessary, grasp each lead with pliers while soldering into place. The pliers will dissipate the heat and prevent damage to the crystal. The band or ring on the crys-

tal is the ground side. Improper connection will produce a positive avc voltage. The crystal should be dressed outside of the transformer terminal lugs.

### **BELMONT-RAYTHEON**

**Chassis 20AY21**

#### **Increased sweep width in low line voltage areas.**

An additional terminal is provided on the C-201-19999 h-v deflection transformer to give an increase in horizontal scan when the receiver is used in low line voltage areas.

The 20-inch receivers installed in low line voltage areas may in some cases have insufficient horizontal scan or inadequate horizontal-size range. This condition can be remedied by connecting the horizontal-yoke winding to the unused primary terminal of the h-v deflection transformer.

When additional horizontal scan is required, remove the chassis from the cabinet and remove the h-v shield can cover, carefully handling the 6BQ6 plate leads. Unsolder the blue lead from terminal 4 and reconnect to terminal 5. Use extreme care when working around the deflection transformer.

### **BELMONT-RAYTHEON**

**Chassis 20AY21**

#### **Poor sync action.**

Poor vertical sync accompanied by horizontal pulling or improper horizontal operation, may in most cases be caused by age plate pulse pick-up at the grid of the sync separator. To remedy this condition, dress capacitor C-103 (470  $\mu\text{f}$  at pin 1 of sync separator) and its leads close to

the chassis and separate resistor R-82 (1 megohm) as far away from the capacitor as possible.

The above modifications were incorporated in later runs of this chassis.

### **BELMONT-RAYTHEON**

**Chassis 20AY21**

#### **Increasing vertical size.**

Resistor R79 (1,200 ohms) in the cathode circuit of the vertical-output tube is changed to 1,000 ohms. This increases the vertical-scan reserve.

### **BELMONT-RAYTHEON**

**Chassis 20AY21**

#### **Improving afc operation.**

Resistor R87 (470,000 ohms) in the afc discriminator is changed to 1 megohm. This balances the afc output at no signal.

### **BELMONT-RAYTHEON**

**Chassis 20AY21**

#### **Increasing range of brightness control.**

R47 (68,000 ohms) connected to one side of the brightness control is changed to 22,000 ohms. This increases the range of the brightness control in order to accommodate picture tubes requiring a greater cut-off bias.

### **BELMONT-RAYTHEON**

**Chassis 20AY21**

#### **Centering range of vertical-hold control.**

Resistors R73 and R76 (10,000 ohms and 470,000 ohms, respectively),

connected to both sides of the vertical-hold control, are changed to 18,000 ohms and 390,000 ohms respectively. This is done in order to center the range of the vertical-hold control.

## BELMONT-RAYTHEON

Chassis 20AY21

### Breakdown of C142.

Capacitor C142 (.05  $\mu\text{f}$  at 200 volts), connected to the green lead of the vertical-output transformer, is changed to .05  $\mu\text{f}$  at 400 volts. This change prevents breakdown of this capacitor in the field.

## BELMONT-RAYTHEON

All Chassis

### Stiffness in tuning.

If stiffness in tuning is noticed, the following is suggested as a means of obtaining a smooth continuous tuning action.

Apply *Lubriplate* or a similar lubrication to the pulleys, pilot-light bar, switch lever and arm. Also check that the switch-lever arm does not bind to the tuning shaft and does not rub against the escutcheon.

Caution: When applying lubrication, care must be used to keep *Lubriplate* off the dial string or slipping and stretching may result.



## BENDIX

Models 2025,  
3033, and 6002

### Improving centering (see Fig. 14).

In order to improve electrical centering of the raster and to facili-

tate easier mechanical adjustment of the focus coil, a revision of the horizontal oscillator and phase-detector circuit may be made as shown in the figure.

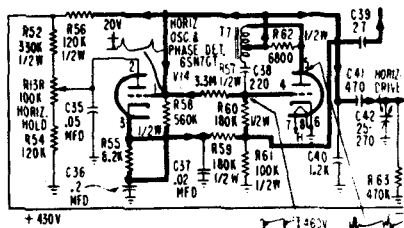

Fig. 14 — Bendix

1. Remove lead of capacitor C39 from the junction of capacitors C40 and C41.

2. Connect this lead of capacitor C39 to the junction of resistors R59, R60, and R61.

3. Remove lead of resistor R58 from pin 3 of V14, 6SN7GT, horizontal oscillator and phase detector.

4. Connect this lead of resistor R58 to the junction of resistor R55 and capacitor C36.

## BENDIX

All Chassis

### Oscillation in i-f amplifiers.

To obtain the i-f bandpass needed for television receivers, stagger-tuned stages are commonly used. Instead of the i-f coils being tuned to the same frequency, they are all tuned to a slightly different frequency, which may cause individual stages to oscillate when not properly aligned. This oscillation may be detected by an exceedingly high output (8 to 15 volts)



at the video test point with no input signal. This high voltage will overload the video amplifier and cause the picture tube to go black.

To locate and tie down oscillation causes, several checks should be made. The most likely cause is misalignment. Traps that are used in any of the i-f stages must be correctly aligned, not only to eliminate sound from the picture, but also to insure that this circuit, in itself, does not become an oscillator. Several other factors may, of course create oscillation, and should be checked. These include:

1. An open screen bypass capacitor in any i-f stage.

2. A decrease in value of any grid resistor, decoupling resistor, or B+ bypass capacitor. Also, but less commonly, a decrease in value of any bias decoupling resistor or capacitor may be the cause.

Less common but possible causes of oscillation may be found to be loose solder joints on ground buss or on components, or even looseness of the cover on the i-f strip.

It must also be remembered that voltmeter probes, screwdrivers, or any metallic material that comes in close contact with the grid or plate circuits will cause the input capacitance to change, and thus cause oscillation. Since the output of the mixer stage is effectively a part of the grid circuit of the 1st i.f., the oscillation may appear to be in the i.f. and actually be due to some component in the mixer circuit.



## CALBEST

16-, 17-, 20-inch  
rectangular and  
19-inch round pic-  
ture tube models

### *Improved vertical circuit (see Fig. 15).*

In later production Calbest television receivers employing 16-, 17-, and 20-inch rectangular, and 19-inch round picture tubes, the 6SN7-GT vertical oscillator-amplifier tube was replaced with a type 6BL7-GT dual-triode. This modification resulted in increased scan and stability, and sustained tube life. To incorporate this change in existing Calbest tv receivers, the vertical oscillator grid and plate resistors are replaced with 250,000 ohm and 2.2-megohm resistors, respectively, a 2,200-ohm cathode resistor is added, and the vertical sync limiting resistor is removed. A schematic diagram of the revised circuit is shown here.

When making these changes, remove the black heater lead of the picture-tube socket from pin 3 of the 6SN7-GT tube socket, and ground to chassis directly.

In the event foldover at the top of the picture is experienced with the 6BL7-GT, add a resistor whose value is from 22,000 to 47,000 ohms to the 250,000 resistor in the grid circuit.

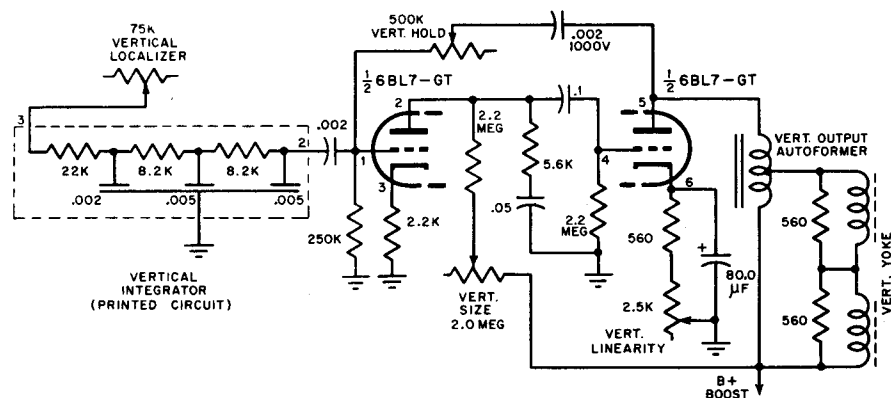

Fig. 15 — Calbest

### CAPEHART-FARNSWORTH

Chassis CX-30,  
A-2 and A-3  
series

#### Horizontal-sync instability.

Horizontal-sync stability is increased as follows:

1. Remove 1-megohm resistor between the picture-tube grid and —B.
2. Reconnect this resistor from pin 3 to pin 4 of the 6H6 tube.
3. Disconnect pin 3 of the 6H6 tube from the —B circuit.
4. Connect a 470,000-ohm resistor from pin 3 of the 6H6 tube to —B.
5. Disconnect the .05- $\mu$ f sync coupling capacitor from the junction of the 3,900-ohm and 1,000-ohm resistors in the 12AU7 second plate-load circuit.
6. Reconnect the capacitor to pin 3 of the 6H6 tube.
7. Change coupling capacitor from pin 2 to pin 4 of the 12SN7 sync amplifier and clipper from 600  $\mu$ mf to 100  $\mu$ mf.

8. Remove the 350- $\mu$ mf by-pass capacitor from pin 6 of the same tube to —B.

9. From the junction of 240- $\mu$ mf and the .002- $\mu$ f capacitors between pin 6 of the same tube and pin 1 of the 12SN7 horizontal oscillator and afc tube, connect a 100- $\mu$ mf capacitor to —B. Note: This 100- $\mu$ mf capacitor may be increased in value to 200  $\mu$ mf if traces of instability persist.

### CAPEHART-FARNSWORTH

Chassis CX-30,  
A-2 and A-3  
series

#### Adding vertical-centering control (see Fig. 16).

A vertical-centering control may be installed by performing the following operations. The control is a 10-ohm, 2-watt center-tapped potentiometer, part No. 450662A-1. It should be installed in some convenient location on the rear chassis apron.

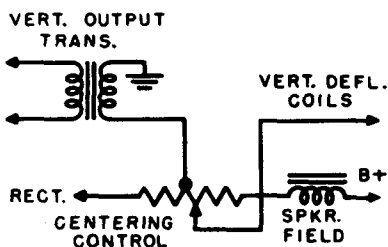

Fig. 16 — Capehart-Farnsworth

1. Connect the control in series with the speaker field coil (filter choke), using the end terminals of the control.
2. Open the vertical output transformer yoke lead.
3. Connect the transformer lead to the fixed center tap on the control.
4. Connect the yoke lead to the variable arm on the control.

## CAPEHART-FARNSWORTH

Chassis CX-30

### Vertical-sync buzz.

The following suggestion will decrease vertical buzz in those CX-30 receivers which have been modified in the field to incorporate the 470-ohm resistor for correction of horizontal centering.

1. Remove the short red wire which connects from the terminal-strip junction of the 220,000-ohm (6T8 plate load) resistor and +B terminal on terminal strip mounted on side wall of chassis (this is the terminal to which is connected the 150,000-ohm, 25L6 screen-grid resistor).
2. Connect a wire from the terminal strip junction of the 220,000-ohm resistor to pin 1 of the speaker socket. This affords a more efficiently filtered

+B supply for the 6T8 audio-amplifier section.

## CAPEHART-FARNSWORTH

Chassis CX-30

### Improving picture detail.

To improve picture detail where proper focus occurs, proceed as follows:

1. Change 10,000-ohm resistor on grid of third i-f tube to 39,000 ohms at  $\frac{1}{2}$  watt.
2. Change 47,000-ohm resistor on grid of fourth i-f tube to 22,000 ohms at  $\frac{1}{2}$  watt.
3. Realign i.f. to same frequencies as originally specified.

## CAPEHART-FARNSWORTH

Chassis CX-30

### Removing picture smear.

The following suggestion has been reported from the field as a corrective method of eliminating picture smear should it occur in certain CX-30 receivers.

Tune the receiver to a channel providing a good signal, turn the contrast control down, and then adjust the fourth picture i-f coil slug while observing the picture. The slug should be turned in (clockwise) approximately  $\frac{1}{2}$  to  $1\frac{1}{2}$  turns. The effect will be noticeable in the received picture as the slug is adjusted. Do not continue to adjust the slug beyond the specified amount or the effect will be detrimental.

Some improvement in picture definition should be noted along with the elimination of any smear. In some cases the definition may be still further improved by also adjusting

L2, the first i-f coil in the same manner.

Smearing may also result from oscillation in the video i-f amplifier.

### **CAPEHART-FARNSWORTH**

**Chassis CX-30**

#### ***Inability to reduce brilliance.***

One instance has been reported where the brilliance of the picture could not be reduced sufficiently by rotation of the brilliance control.

If such a case is encountered in the field, it would probably be wise to check the picture tube by substitution if another tube is available. Also, the two by-pass capacitors in the cathode circuit of the picture tube should be checked or replaced, as well as the brilliance control itself, and the .1- $\mu$ f coupling capacitor to the picture-tube grid.

If it is necessary to further reduce brilliance in a special case, it is possible to do this by replacing the 220,000-ohm resistor in the cathode circuit of the picture tube with a 100,000-ohm resistor.

### **CAPEHART-FARNSWORTH**

**Chassis CX-30**

#### ***Increasing range of focus control.***

To increase the operating range of the focus control, proceed as follows:

1. Reduce current-limiting resistance in series with focus control from 1,000 ohms to 220 ohms,  $\frac{1}{2}$  watt.

2. Remove the two 10,000-ohm, 2-watt resistors which are connected in series between +B and the focus coil, if used.

### **CAPEHART-FARNSWORTH**

**Chassis CX-30**

#### ***Radio interference from horizontal-sync radiation.***

Radio interference may be the result of radiation from the width control and the horizontal-yoke leads. Observe the following steps for correction:

1. Relocate width control under rear apron of chassis, or inside high-voltage power supply compartment.

2. Shorten horizontal-deflection leads (brown) to deflection yoke, and dress leads close to chassis and yoke-support brackets.

3. If further reduction of radiation is required, shield bottom of chassis with small rectangular piece of light metal under width control. Shield must be grounded to chassis.

### **CAPEHART-FARNSWORTH**

**Chassis CX-30**

#### ***Inability to center picture horizontally.***

A fixed d-c bias may be applied to the horizontal-deflection coils of early CX-30 chassis to assist in horizontal centering by the following operations:

1. Remove jumper from pin 1 of the speaker socket to end terminal of the height control.

2. Connect a new wire from terminal of height control where jumper was removed to the free center terminal on the terminal strip mounted on the side of the chassis under the horizontal-scanning circuits.

3. Connect a 470-ohm, 1-watt resistor from this terminal on terminal strip to the adjacent terminal where

the white wire from the deflection yoke connects.

4. Connect a 4- $\mu$ f, 50-volt electrolytic capacitor from the +B terminal of the height control to pin 1 of the speaker socket.

Note: To prevent buzz, remove from the end terminal of the height control, the read lead which passes around the corner of the chassis and carries +B voltage to the audio stages. This lead should be connected directly to pin 1 of the speaker socket.

### CAPEHART-FARNSWORTH

#### Chassis CX-30

#### *Horizontal foldover.*

To prevent horizontal foldover proceed as follows: Remove feedback circuit from terminal 4 of the horizontal-output transformer back to junction of the 6- $\mu$ f capacitor and the 150,000-ohm resistor in the horizontal-oscillator circuit. Remove this feedback circuit completely, including the two 6- $\mu$ f capacitors and the two 560,000-ohm resistors, and the brown lead to the output-transformer terminal. The 150,000-ohm resistor should be left in place.

### CAPEHART-FARNSWORTH

#### Chassis CX-31

#### *Improved horizontal sync.*

Changes in value of components in this circuit may cause the horizontal oscillator to shift frequency, thus making it harder for the control circuit to maintain the oscillator within sync range. It is recommended that when unstable horizontal sync is encountered, the following changes be made:

Change the 180- $\mu$ f capacitor (connected between pin 4 of *V14* and the horizontal-oscillator transformer) and the 390- $\mu$ f capacitor (coupling capacitor between the horizontal-oscillator transformer and *V15*) to silver mica capacitors of the same value.

### CAPEHART-FARNSWORTH

#### Chassis CX-31

#### *Horizontal tearing or "snaking."*

The term "snaking" is usually employed to describe a condition wherein the picture "weaves" from side to side at a steady rate. This usually is caused by a 60- or 120-cycle source on the chassis being coupled into the video circuits. This condition can usually be corrected by replacing defective by-pass or filter capacitors.

The second condition which is sometimes referred to as "snaking" is actually horizontal tearing caused by video signals being coupled into the sync circuits. This condition will be prevalent only during the reception of regular programs; it will not show up in a test pattern. To eliminate this tearing, it is suggested that the 1-megohm resistor between pins 1 and 3 of *V11* be changed to 470,000 ohms and the 100- $\mu$ f capacitor between pins 2 and 4 of *V11* be changed to 1,000  $\mu$ f. As a final step, the alignment of the chassis should be checked and corrected as required.

### CAPEHART-FARNSWORTH

#### Chassis CX-31

#### *Increased horizontal scan.*

To increase horizontal scan on early production models proceed as follows:

1. Replace 6BG6-G screen grid dropping resistor (10,000 ohms at 2 watts) with a 6,800-ohm, 2-watt resistor.

2. Replace the 33,000-ohm, 1-watt plate-supply resistor for the horizontal afc tube with a 15,000-ohm, 1-watt resistor.

3. Remove the negative lead from the 500- $\mu\text{mf}$ , 15-kv filter capacitor from terminal 4 of the horizontal-output transformer and connect it to chassis ground.

### CAPEHART-FARNSWORTH

Chassis CX-31

#### *Elimination of 120-cycle hum.*

To eliminate hum in early production CX-31 chassis, connect a short jumper (use white wire to maintain color code) between the junction of the 18,000-ohm resistor and the 250- $\mu\text{h}$  peaking coil (in the second video amplifier section) and the junction of the 220-ohm, 2-watt and 220,000-ohm resistors in the 6V6 cathode circuit.

### CAPEHART-FARNSWORTH

Chassis CX-31

#### *Horizontal picture foldover.*

To eliminate horizontal picture foldover, proceed as follows:

1. Change the value of the 6BG6-G cathode by-pass capacitor from .2  $\mu\text{f}$  to 4  $\mu\text{f}$  at 100 volts (electrolytic).

2. Remove the feedback circuit consisting of a 5- $\mu\text{mf}$  capacitor and a 560,000-ohm resistor connected in series to pin 5 of the 6W4 damper tube.

3. Change the value of the coupling capacitor between the sync clipper

and the horizontal oscillator from 180  $\mu\text{mf}$  to 100  $\mu\text{mf}$ .

4. Remove the connection from the first anode of the picture tube (pin 10) and connect a 100,000-ohm, 1/2-watt resistor from pin 10 of the picture tube to pin 3 of the damper tube (6W4).

5. Connect one end of a parallel combination of a 100,000-ohm, 1/2-watt resistor and a 33- $\mu\text{mf}$  capacitor to pin 10 of the picture tube and the other end, in series with a .01- $\mu\text{f}$ , 400-volt capacitor, to pin 4 on the deflection-cable socket.

### CAPEHART-FARNSWORTH

Chassis CX-33

#### *Lack of brilliance.*

Most of the above chassis now in the field have a 50,000-ohm shading potentiometer (R235) and a 27,000-ohm series resistor (R236). Another 27,000-ohm resistor may be added in series with the -90 volt side of the shading pot and, at the same time, an anti-blooming circuit (a 100,000-ohm resistor paralleled by a .1- $\mu\text{f}$  capacitor) should be added in series with the picture-tube cathode circuit.

### CAPEHART-FARNSWORTH

Chassis CX-33

#### *Failure of 6BG6.*

CX-33 chassis in which several 6BG6 tubes have either failed prematurely or given intermittent horizontal shrinkage can be corrected with the following change. The 6BG6 cathode resistor is increased to 220 ohms total. This may be accomplished by adding a 110-ohm, 2-watt resistor

or two paralleled 220-ohm, 1-watt resistors in series with the present cathode resistor, (ref. Nos. *R291* and *R292*). The screen resistor should be changed to a total value of 12,000 ohms at 2 watts. These changes make the 6BG6 bias less dependent upon the amount of horizontal drive received from the 6SN7 horizontal oscillator.

### CAPEHART-FARNSWORTH

Chassis CX-33

#### Increased horizontal scan.

*C278*, a 30- $\mu\text{mf}$ , 6,000-volt capacitor may be added between pin 3 of *V220* damper tube and chassis ground. The schematic shows *C278* to be 25  $\mu\text{mf}$ , 5,000 volts; however, its present correct value is 30  $\mu\text{mf}$ , 6,000 volts. The addition of this capacitor provides approximately 1 inch additional horizontal scan (or width). A later production change to increase horizontal scan adds a .1- $\mu\text{f}$  200-volt capacitor across *R291* in the cathode circuit of *V219*, 6BG6 horizontal-output.

### CAPEHART-FARNSWORTH

Chassis CX-33

#### Elimination of sound modulation in sync.

Terminal *B* of *T209*, horizontal-oscillator transformer, is now connected to the junction of *R283* and *R284* rather than directly to +235 volts. This provides the decoupling action of *R284* and *C254* for the plate supply to *V217*. Sound modulation in the horizontal-sync circuit resulted in a wiggle or swaying of the picture horizontally.

### CAPEHART-FARNSWORTH

Chassis CX-33

#### Increased vertical scan.

To increase vertical scan, *R262* may be changed from 2.2 megohms to 3.9 megohms, and *R266* may be connected to +310 volts instead of +295 volts. For an additional increase in vertical scan, *V215*, a 6K6GT tube, may be replaced with a 6V6GT in those sets which require it. No circuit changes are necessary for this replacement.

### CAPEHART-FARNSWORTH

Chassis CX-33

#### Adjacent channel sound trap

(see Fig. 17).

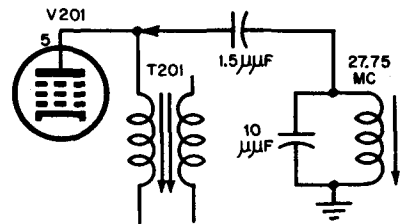

Fig. 17 — Capehart-Farnsworth

An adjacent channel sound trap tuned to 27.75 mc is available for incorporation in the CX-33 chassis in the field, in those localities in which this type of interference is encountered. The trap is such that it can be easily installed in an already drilled chassis hole near the 1st video i-f amplifier tube. The trap is to be connected electrically to the plate of the 1st video i-f tube through a 1.5- $\mu\text{mf}$  capacitor. A sketch showing this trap schematically is shown.

Part No. of the trap is 650299A-1; part No. of the 1.5- $\mu\text{mf}$  capacitor is 650030A-9.

A suggested procedure for tuning this trap after its installation, is to first tune the receiver to the channel on which the interference is obtained (if possible) and then adjust the trap to eliminate the interference. After doing this, check the over-all i-f response curve and make adjustment to the i-f transformers, if necessary. The trap then can be readjusted slightly if any further interference is noted. In no event should this trap be installed without checking the over-all i-f curve.

### **CAPEHART-FARNSWORTH**

**Chassis CX-33**

#### ***Preventing arcing and corona in high-voltage supply.***

The following changes, already incorporated in later production runs, may be incorporated to prevent high-voltage arcing:

The heavy red lead in the h-v supply section may be shortened in order to maintain proper dress. The high-voltage filter capacitor mounting nut may be soldered to the chassis to prevent it, and hence the 1B3 socket, from rotating and causing arcing between the 1B3 filament leads and the high-voltage winding of *T210*.

A high-voltage insulating material may be high-voltage applied to the 1B3 plate-cap lead at its connection to the high-voltage winding; this is to prevent corona between this point and the high-voltage supply shield. The 1B3 and 6W4 socket terminals and wiring may be coated with a high-voltage insulating material to prevent corona.

### **CAPEHART-FARNSWORTH**

**Chassis CX-33**

#### ***Failure of R-258.***

*R-258* is a 2,200-ohm, 1/2-watt plate-load resistor supplying the plate of the *V214A* sync clipper tube in early CX-33 chassis. Some reports have been received stating that this resistor has opened up after a period of operation resulting in a lack of vertical sync. It is suggested, if this resistor is found defective, that it be replaced with a 2,200-ohm, 1-watt resistor for an additional margin of safety.

### **CAPEHART-FARNSWORTH**

**Chassis CX-33**

#### ***Intermittent vertical-sync buzz.***

Most reports of intermittent sync buzz can be attributed to overmodulation at the tv transmitter for which, of course, there can be no simple correction at the receiver end. Always check with the tv transmitter's engineers first upon receiving reports of intermittent sync buzz troubles.

At the receiver, this trouble may be the result of insufficient drive at the ratio detector, resulting in lowered a-m rejection. Increased drive can be obtained by supplementing the coupling of the sound take-off transformer (*T204*) with a 3- $\mu\text{mf}$  capacitor. Connect the capacitor between terminals 2 and 4 of *T204*. After adding this capacitor, the primary and secondary of *T204* must be re-aligned carefully.

In addition to reducing sync buzz, this increased coupling will also provide an increase in sound output. Therefore, on reports of low sound output (where alignment is found to be OK), the addition of this capacitor is recommended.



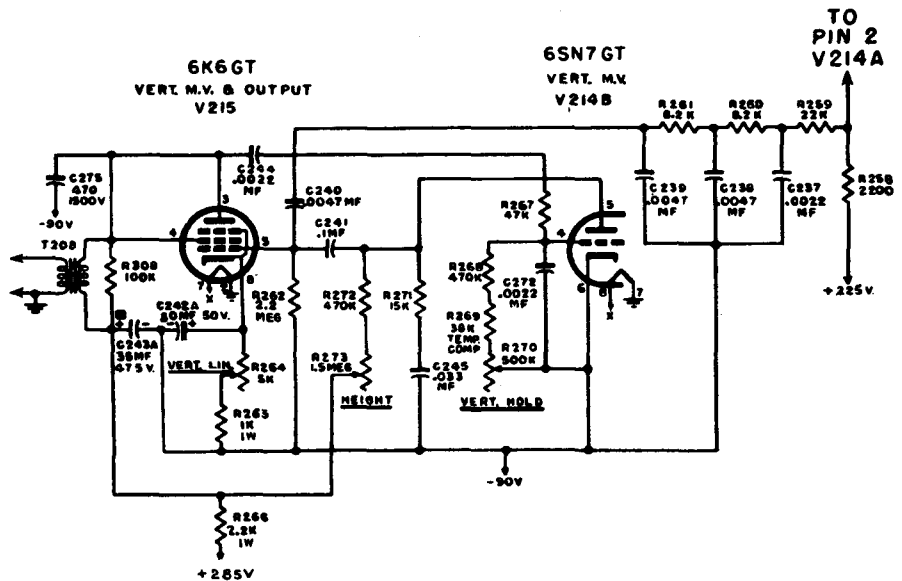

Fig. 18 — Capehart-Farnsworth

### CAPEHART-FARNSWORTH

Chassis CX-33

#### Improved interlace (see Fig. 18).

The vertical sync take-off point is changed from the plate to the cathode of *V214A*. A few other changes were made in the vertical multivibrator to improve interlace. Refer to the schematic diagram for details.

### CAPEHART-FARNSWORTH

Chassis CX-33

#### Increased range of vertical-hold control.

*R270*, Vertical Hold Control, is changed from a 500,000-ohm to a 1.5-megohm potentiometer to increase the hold range of this control.

### CAPEHART-FARNSWORTH

Chassis CX-33

#### Improved sync clipping.

The junction of *R254* and *R253* is changed from chassis ground to -90 volts. *R242*, plate-load resistor for *V212*, is decreased from 47,000 to 33,000 ohms. These changes provide improved sync amplification and clipping. *R255* in the plate circuit of *V213* is changed from 22,000 ohms at 1 watt to 47,000 ohms at 1 watt and *R314* also 47,000 ohms at 1 watt is connected in parallel with it. This change is to provide adequate wattage tolerance.

### CAPEHART-FARNSWORTH

Chassis CX-33

#### Whistle in sound and lines in picture.

A whistle in the sound which may be accompanied by lines in the picture that are similar to the Barkhausen effect may be due to the fact that *C-242D* (electrolytic, between -90 and chassis ground) has a higher than normal impedance at the horizontal-oscillator frequency. To improve by-passing at this frequency, a .1- $\mu$ f, 200-volt capacitor is connected from the -90 volt point (junction of *R-291* and *R-290*, near the 6BG6 tube) and chassis ground.

### CAPEHART-FARNSWORTH

Chassis CX-33

#### Difficulty in adjustment of take-off transformer.

If difficulty is encountered in accurately aligning to 4.5 mc the primary of the sound take-off transformer (*T204*), it is possible that, due to variations in material, the tuning range has deviated. A 5- $\mu$  $\mu$ f capacitor connected from terminals 3 and 4 of *T-204* should correct this condition.

### CAPEHART-FARNSWORTH

Chassis CX-33

#### Improved picture focus.

If picture focus lacks sharpness, it may possibly be improved by connecting a 2,200-ohm, 2-watt resistor in parallel with *R-297* (focus control) and *R-296B*. This connection can be made at the terminals of the filter capacitors *C-243C* and *C-264B*. Above change should be tried only after carefully making normal adjustment to obtain proper focus.

### CAPEHART-FARNSWORTH

Chassis CX-33

#### Excessive snow due to agc action (see Fig. 19).

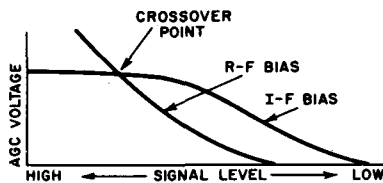

Fig. 19 — Capehart-Farnsworth

The CX-33 chassis employs an agc system wherein differential bias is supplied to the r-f and i-f stages. This means that at low signal levels, more agc voltage is applied to the i-f stages than to the r-f stage, while at high signal levels, more agc is applied to the r-f stage than to the i-f. Therefore, there is a point of cross-over at some value of signal level where the i-f and r-f bias is the same. This is illustrated in the graph showing the r-f and i-f bias curves with variable signal.

Some reports have been received of excessive snow in moderate signal areas. This has been found to be caused, in certain cases, by a variation of resistance in *R-252* and/or *R-248* resulting in the agc cross-over point occurring at too low a signal level. A test is being incorporated in production wherein a 1,000-micro-volt signal must produce a relatively snow-free picture. *R-252* (2.4-meg-ohm), *R-248* (24,000-ohms), and *R-250* (120,000-ohms) must all be held within their 5 percent tolerance. In cases of excessive snow, these resistors should be checked for proper values. Since *R-248* and *R-250* are

fairly low values, it is difficult to ascertain a 5 percent change in their resistance without the use of a bridge. Therefore, it is suggested that where a noticeable resistance change is not found in R-248 or R-250, that R-252 be changed to 2.2 megohms or, if snow is still excessive, to 2.0 megohms. This has been found to remedy the condition in most cases.

### CAPEHART-FARNSWORTH

Chassis CX-33

#### *Intermittent decrease in horizontal scan.*

A chassis developing the above mentioned trouble will have sufficient scan when first turned on. The width will decrease over a ten to fifteen minute period in most cases to about two-thirds original size then, gradually over a period of approximately one hour, the width will increase to normal size.

This trouble has been found to be the result of excessive winding capacitance and insufficient baking of the isolation transformer in the damper tube heater circuit. This transformer (part No. 650243A-1) is supplied by more than one vendor; this difficulty has been found to exist only in those transformers identified by the code letters "BC" following the part number. This transformer should be replaced.

As soon as the vendor in question can correct the above mentioned difficulty this transformer will again be accepted for use. These transformers will bear the code letters "BC", however, they will be identifiable by the code dating which will be 037 or higher.

### CAPEHART-FARNSWORTH

Chassis CX-33

#### *Failure of 6,000-volt capacitor, C-278.*

The original capacitor used in the receiver may have failed due to heat from the 6BC6. A new capacitor, part No. 650310A-2, has a wax coating unaffected by high temperatures. Life tests, and field reports have shown this new capacitor to be entirely satisfactory.

### CAPEHART-FARNSWORTH

Chassis CX-33

#### *Internal arcing in h-v capacitor (see Fig. 20).*

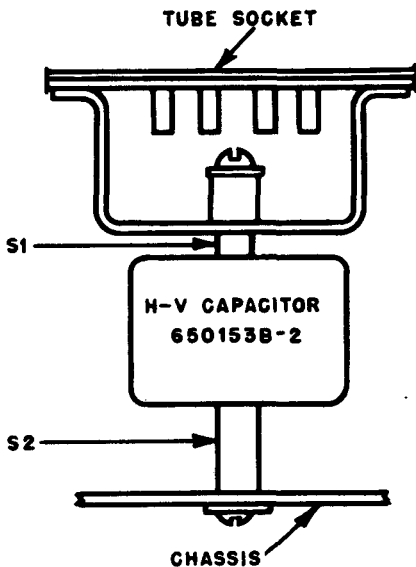

Fig. 20 — Capehart-Farnsworth

This is the 500- $\mu\mu\text{f}$ , 200,000-volt high-voltage filter capacitor, part No. 650153B-2.

It is possible that the Jeffers Electronics capacitor may be subject to

failure, possibly caused by absorption of moisture in the dielectric or to mechanical failure in the event of being abused at time of assembly. This breakdown may not be apparent at once but may possibly show up over a period of several weeks in operation.

The failure of subject capacitors could be the result of a mechanical strain on the solder joint inside the capacitor where the stud is connected to the silver deposit on the ceramic dielectric. Excessive torque applied between the two studs or between the body of the capacitor and a stud during assembly or replacement may break the soldered joint or tear the silver away from the dielectric.

In assembling the capacitor to the bracket, part No 450512B-1, the assembly should be held by the bracket, not by the capacitor, as the screw is tightened. The double-D hole in the bracket prevents rotation between the bracket and stud S1.

In mounting the bracket-capacitor assembly on the chassis, stud S2 should be held by a pair of gas pliers as the mounting screw is tightened, so as not to produce any torque between S2 and the body of the capacitor.

## CAPEHART-FARNSWORTH

Chassis CX-33

### Lead dress in h-v compartment

(see Fig. 21).

If necessary to replace the 1B3 rectifier tube in h-v section of the receiver, it is possible, if care is not exercised, to disarrange the wiring. This might cause high-voltage arcing or a short to develop resulting in a burned-out transformer. Note carefully in the sketch the proper position of the 1B3 socket, so as to avoid drawing the filament-supply leads against the transformer coil. Also note correct position of the heavy red wire between the horizontal-output transformer and the deflection yoke.

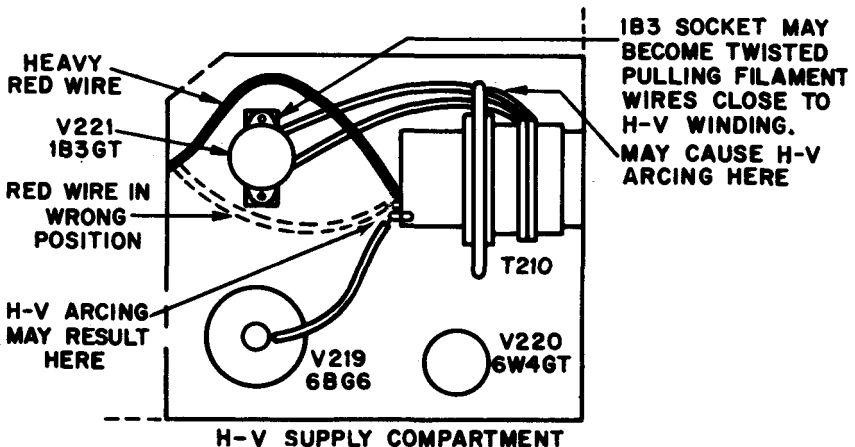

Fig. 21 — Capehart-Farnsworth

It must be between the 1B3 tube and power-supply shield — not between the 1B3 and 6BG6 tubes.

### CAPEHART-FARNSWORTH

Chassis CX-33

#### Preventing blocking on strong signals (see Fig. 22).

Remove the present leads from the positive terminal of *C242B*, connect together and insulate. Connect a 5,000-ohm, 7-watt wire-wound resistor between the positive terminals of *C243C* and *C242B*. This resistor is indicated in the diagram as *R318*. Remove *R236* from the +135-volt

board to which the primary leads of the vertical-output transformer are connected.

### CAPEHART-FARNSWORTH

Chassis CX-33

#### Reducing picture blooming.

Connect in series with the lead to pin 11 (cathode) of the picture tube a parallel combination of a 100,000-ohm resistor and a .1- $\mu$ f 200-volt capacitor. Care should be taken that undue stray capacitance is not introduced between the cathode lead of the picture tube and ground. This change is also shown in the diagram for the previous cure.

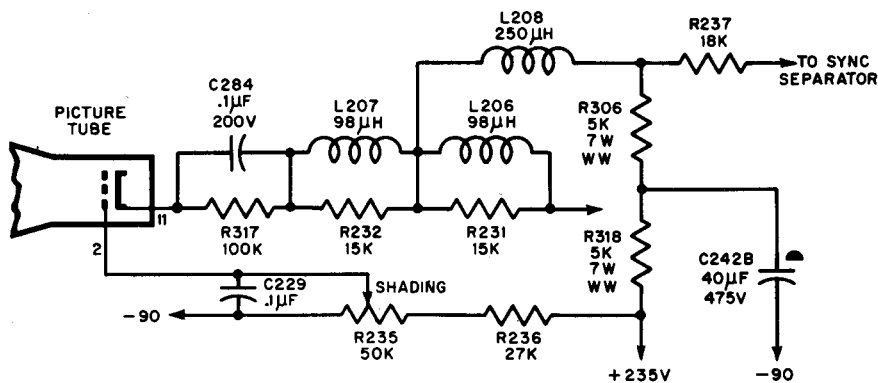

Fig. 22 — Capehart-Farnsworth

circuit and connect to the +235-volt circuit. Remove *R306* from the +135-volt circuit and connect to *C242B*. To provide by-passing at the +135-volt tap, add a 20- $\mu$ f 450-volt tubular capacitor between this point and ground. This capacitor should be connected to the terminal board to the front of the 4.5-mc sound i-f stage and the ground lug of the terminal

### CAPEHART-FARNSWORTH

Chassis CX-33

#### Increasing horizontal scan.

The 30- $\mu$ f, 6,000-volt capacitor, *C278*, part No. 450954A-3, which was previously connected between the cathode of the 6W4 damper tube and ground to increase width should be reconnected between the 6BG6 plate

connection of the high-voltage coil and ground to further increase width.

A soldering lug should be attached to the inside wall of the power-supply housing in line with the present hole through which the yoke lead comes out and approximately  $2\frac{1}{4}$  inches from the rear of the chassis. Care should be taken when installing the capacitor so that it does not come in contact with either the 1B3 or 6BG6 tube. A wire ground should be installed between the terminal lug and the chassis to provide proper grounding. An easy method of connecting

this is to run wire through the vent hole closest to the 6BG6 socket and ground the wire to the saddle of the socket.

## CAPEHART-FARNSWORTH

Chassis CX-33

### Adjacent channel trap

(see Fig. 23).

For the few areas where severe adjacent-channel interference is encountered, a special trap is available. This trap, part No. 750261A, is a combined first i-f transformer and

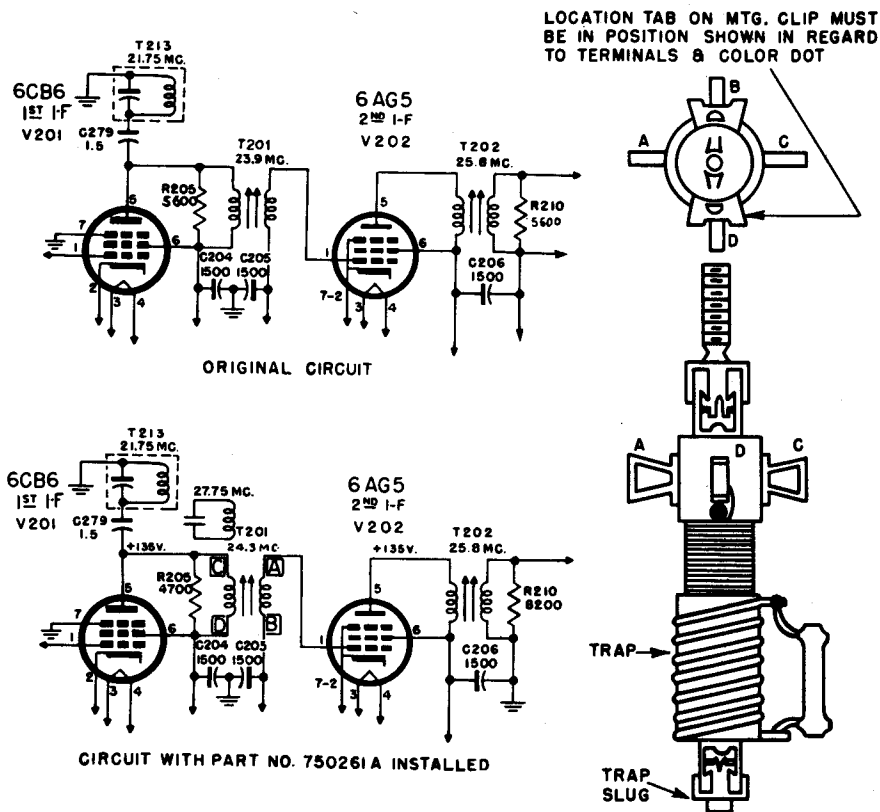

Fig. 23 — Capehart-Farnsworth

trap and replaces the original first i-f transformer.

To install, the following steps are taken in order:

1. Remove original first i-f transformer, also *R205* (5,600-ohms) and *R210* (5,600 ohms).

2. Replace *R205* with a 4,700-ohm resistor and *R210* with an 8,200-ohm resistor; also wire in combined trap and first i-f transformer. Leave 21.75-mc trap in circuit.

3. Adjust trap slug on first i-f to 27.75 mc first, then peak first i-f slug to 24.3 mc. Note: In original circuit the first i.f. was peaked at 23.9 mc.

4. Adjust second i-f slug to 25.8 mc. The over-all response curve should be checked by use of a sweep generator, oscilloscope, and markers to insure proper results.

### CAPEHART-FARNSWORTH

#### Chassis CX-33

#### ***Elimination of sync buzz due to transmitter overmodulation.***

In order to prevent sync buzz in a receiver, it is necessary that the amplitude of the video carrier at the second detector be not less than the amplitude of the sound carrier. In order to provide for this relationship in the transmitted signal, the RTMA has set a standard for maximum video modulation at 90 percent. It is believed that this maximum is exceeded by some tv stations.

Under these conditions then, the only alternative is to provide additional attenuation of the sound carrier in the receiver. To do this in the

CX-33 chassis, the following two suggestions may be tried.

1. Realign the i-f stages for a 3-mc bandwidth. This can be done by tuning *T101* to 23.5 mc instead of 23.0 mc, and leaving the sound trap *T213* in the circuit.

2. If further attenuation is required, the coupling capacitor (*C279*) to the sound trap can be increased to 3  $\mu\text{f}$ . When making this change, the i-f curve should be checked to insure that the high video frequencies are not attenuated too much. In order to insure sufficient sound output after making these changes, a 3- $\mu\text{f}$  capacitor should be connected between terminals 2 and 4 of *T204*, the sound take-off transformer.

### CAPEHART-FARNSWORTH

#### Chassis CX-33

#### ***Critical focus adjustment.***

Following investigation of this condition, it was found that a small quantity of CX-33 chassis may be connected so that the direction of taper of the *Focus Control* is reversed. As a result of this reversal of taper, the focusing point is more critical, although the control will pass through focus.

To check for proper connection of this control, set the *Focus Control* to the center of its rotation and measure the resistance between its center terminal and the unused outer terminal. This should be approximately 3,500 ohms. If the resistance measured is closer to 1,000 ohms, the outer terminal connection should be reversed.

## CAPEHART-FARNSWORTH

Chassis CX-33

### Excessive picture height.

Some deflection yokes (part No. 750155A-4) bearing the *Telectron* name may provide as much as 2½ inches of additional height over the yokes received from other vendors. In those sets using this yoke with which the size cannot be reduced sufficiently, the following changes can be made:

1. Connect the high side of *R-266* (2,200 ohms, 1 watt) to +295 volts buss instead of +310 volts.

2. Change value of *R-268* from 560,000 ohms to 1-megohm. Note: If vertical foldover is encountered in making these changes, connect a .0047- $\mu$ f, 600-volt capacitor (part No. 2248-4720) across *C-245*.

## CAPEHART-FARNSWORTH

Chassis CX-33

### Modification for improved fringe-area operation (see Fig. 24).

It is possible, under particularly severe conditions, that greater range of the contrast control may be required without loss of sync. If so, a

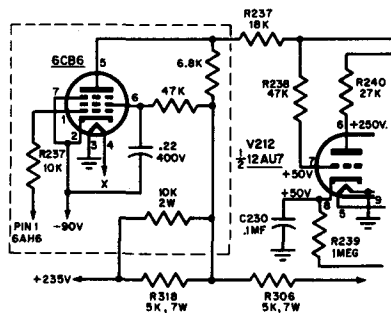

Fig. 24 — Capehart-Farnsworth

6CB6 sync-amplifier tube may be easily installed on the chassis between the 6AL5 (*V204*) and 12AU7 (*V212*). Using a socket punch, cut a 5/8-inch hole in the chassis. Install socket and wire as shown in the figure.

The 10,000-ohm, 2-watt resistor is shunted across *R318* to compensate for the increased current of plate and screen of 6CB6. When 6CB6 sync amplifier tube is added, the 220-ohm shunt should not be used across the contrast control.

This change, while not actually increasing the sensitivity of the standard chassis, does provide a very pleasing picture under very difficult reception conditions.

## CAPEHART-FARNSWORTH

Chassis CX-33

### Increased tube life for 6AH6.

The useful life of the 6AH6 (video amplifier) used in this chassis may be increased by increasing the value of the screen grid dropping resistor from 27,000 ohms to 39,000 ohms.

## CAPEHART-FARNSWORTH

Chassis CX-33

### Blanking of vertical-retrace lines (see Fig. 25).

This change will blank out the vertical-retrace lines which may be objectionable. The following changes may be made as shown in the diagrams.

The original circuit has *R271* connected above the capacitor *C245*, and the shading circuit shown with a 200,000-ohm potentiometer, *R235* and *R236* as a 68,000-ohm resistor.



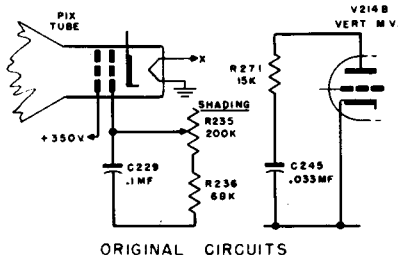

ORIGINAL CIRCUITS

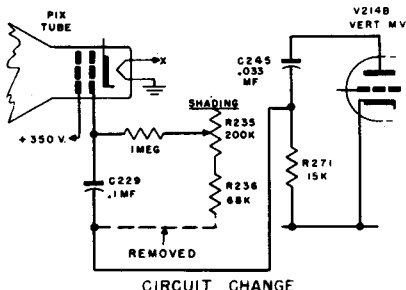

CIRCUIT CHANGE

Fig. 25 — Capehart-Farnsworth

The changes are shown in the circuit where  $R271$  is connected below  $C245$ . Between the junction of the capacitor and resistor ( $C245$  and  $R271$ ) a lead is taken to  $C229$ . The existing connection from  $C229$  to  $R236$  is taken out. The variable leg of the potentiometer  $R235$  is connected in series with a 1-megohm resistor (the only part added in this change).

## CAPEHART-FARNSWORTH

Chassis CX-33

### Improved fringe-area operation (see Fig. 26).

Improved fringe-area operation will result if the changes described below are made. One of the main effects is to eliminate objectionable snowy pictures and noise streaks so common to reception in noisy fringe

areas. The following components are required:

Part No.	Description
750266A-2	Contrast control 1.5k
36230	Palnut
3229-221	200-ohm resistor
2246-2240	.22- $\mu$ f, 200-v capacitor
3229-474	470k resistors (2 required)
450464A-3 or	Knob (mahogany)
450464B-1	Knob (blonde)

1. Remove leads from pin 7 of 6AH6 and connect to pin 2.

2. Break the lead between pin 2 and pin 7 of 6AH6.

3. Install contrast control in hole already provided in front of the chassis. Connect center arm to pin 7, 6AH6 tube. Connect cw end of contrast control to pin 2, 6AH6.

4. Shunt contrast control with 220-ohm resistor between pins 2 and 7 of 6AH6 tube.

5. If chassis does not have anti-bloom circuit, an additional part No. 2246-1040 (.1- $\mu$ f, 200-volts capacitor,  $C284$ ) is required.

6. To maintain blackground brilliance with reduction in contrast, clip out  $R-317$  shunting .1- $\mu$ f capacitor in anti-bloom circuit and replace with 470,000-ohm resistor.

7. Install another 470,000-ohm resistor between pin 11 (cathode of picture tube) and chassis ground.

8. Shunt  $C-250$  (.047- $\mu$ f capacitor in cathode of  $V216$ ) with .22- $\mu$ f capacitor. This is particularly useful where noise tears the picture horizontally.

Note: When setting up, be sure that agc is set so picture will not quite fall out of sync with extreme ccw setting of contrast control.

### CAPEHART-FARNSWORTH

Chassis CX-33 with  
19- or 20-inch picture tubes

#### Picture ringing.

This condition can be easily corrected by adding a 10,000-ohm resistor in series with the 56- $\mu$ f capacitor connected across one-half of the horizontal winding of the deflection yoke. The addition of the resistor will decrease the picture by approximately 1 inch; however, sufficient width will still be available.

### CAPEHART-FARNSWORTH

Chassis CX-33DX

#### Intermittent horizontal picture shift.

A small quantity of bleeder resistors (*R298*) have been found to be defective, in that the +3.5 volt terminal is mechanically loose. Slight vibration will cause a slight change in resistance of the 8,700-ohm section which results in a voltage change on the +3.5 volt line. Since this voltage is applied to the reactance-tube cathode, any variation will have an effect on the horizontal afc, resulting in horizontal phase shift. Any resistors defective in this manner should, of course, be replaced.

### CAPEHART-FARNSWORTH

Chassis CX-33DX

#### Vertical linearity instability.

A condition of vertical linearity instability evidenced by a cyclic, or

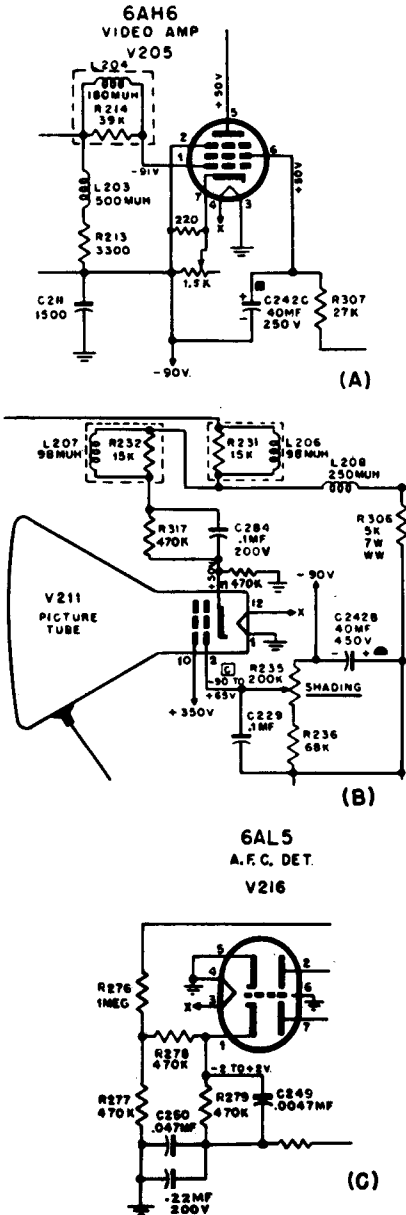

Fig. 26 — Capehart-Farnsworth

repetitive, expansion and contraction in the vertical direction of a portion of the picture can be corrected by the following circuit change. Remove the center arm of the *Height Control* (R273) from +310 volts and connect to the junction of R266 and C243A. Remove R266 from +310 volts and connect to +295 volts. All connections are in a convenient position and it should take only a few seconds to change the two wires involved.

#### CAPEHART-FARNSWORTH

Chassis CX-33DX

##### *Elimination of "tweet" due to i-f harmonic.*

To eliminate the "tweet" due to i-f harmonic feedback in the video detector, proceed as follows:

1. L219 (2.7- $\mu$ h choke) is added between the -90-volt buss and the low side of T203 secondary (previously T203 was returned directly to -90v).

2. The low side of C209 is disconnected from -90 volts and connected instead of the junction of L219 and T203. The high side of C209 remains as connected.

3. C211 (1,500  $\mu$ mf) is deleted.

#### CAPEHART-FARNSWORTH

Chassis CX-33DX

##### *Improved vertical sync.*

The vertical sync may be improved as follows:

1. R259 (plate load for V214A) is changed from 10,000 ohms to 22,000 ohms.

2. R265 (in the cathode of V214B) is changed from 2,700 ohms to 3,300 ohms.

3. C240 (coupling to vertical integrator) is changed from .01  $\mu$ f to .047  $\mu$ f.

#### CAPEHART-FARNSWORTH

Chassis CX-33DX

##### *Overloading at normal agc setting.*

The 1st sync amplifier may be modified as follows to prevent overloading "snaking" at normal agc setting:

1. R351 (100k, 1 watt) is connected from pin 6 of V204 to the +235-volt buss. (Previously pin 6 was grounded.)

2. C302 (.22  $\mu$ f, 450v) is connected across R351.

3. R233 and R234 are changed from 100k each to 47k each.

#### CAPEHART-FARNSWORTH

Chassis CX-33DX

##### *Eliminating bending at top of picture.*

The horizontal afc circuit may be changed as follows to eliminate "flag-waving" or bending of the picture at the top:

Add R350 (10,000 ohms at  $\frac{1}{2}$  watt) and C305 (.22  $\mu$ f at 200 volts) in series across C250.

#### CAPEHART-FARNSWORTH

Chassis CX-33DX

##### *Improved sync stability.*

The following changes may be made in the sync circuits to improve sync stability:

1. R351 is changed from 100k, 1w to 47k,  $\frac{1}{2}$ w and connected to the +135v line instead of +235v line.

2. *C302* is changed from .22  $\mu\text{f}$  to 10  $\mu\text{f}$  and was connected from pin 6 of *V204* to the -90v line instead of across *R351*.

3. *R243* is changed from 1 megohm to 470k.

4. *R255* and *R314* are changed from 47k to 100k each.

## CAPEHART-FARNSWORTH

Chassis CX-33DX

### Improved operation of agc control.

To provide smooth operation of the *AGC Set Control*, the resistor in series with the control (*R243*) may be changed from 330,000 ohms to 1 megohm.

## CAPEHART-FARNSWORTH

Chassis CX-33DX

### Improved vertical stability.

The following change in the vertical multivibrator will improve the stability of this circuit: Change *C244* from .001  $\mu\text{f}$  to .0012  $\mu\text{f}$  at 1,000 volts. As a temporary measure, a .001- $\mu\text{f}$  capacitor in parallel with a 270- $\mu\text{mf}$  capacitor may be employed.

## CAPEHART-FARNSWORTH

Chassis CX-33DX

### Preventing voltage breakdown between yoke windings (see Fig. 27).

Some high-voltage breakdowns between yoke windings have been reported in yokes 750192A and B which are furnished with models 335 and 337 (with the above chassis). To reduce the potential difference between windings, the following change procedure should be followed:

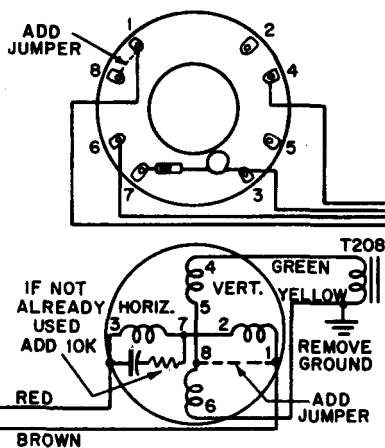

Fig. 27 — Capehart-Farnsworth

1. Remove the chassis.

2. The yellow lead from the yoke was originally connected to the low side of the vertical-output transformer at a terminal which is also grounded to the chassis. Remove these two leads from the ground terminal and connect them to any convenient unused terminal which is *not* connected to chassis ground.

3. Slip the insulating cap-cover from the back of the yoke. The yoke need not be removed. Numbers 1 through 8 are printed adjacent to each terminal on the outer circumference of the yoke cover. Add a jumper between terminals 1 and 8.

4. As a precautionary measure, wrap *Scotch* tape around the green lead from terminal 4 where it crosses terminal 3.

5. Part 750192B yoke has a 10k resistor added in series with the 56- $\mu\text{mf}$  capacitor across terminals 3 and 7. If you are modifying a part 750192A yoke, this 10k resistor

should be added to eliminate bent raster lines on the left edge of the picture.

6. Replace yoke cap and reinstall chassis.

Note: Replacement 750192 yokes supplied by the manufacturer should have this jumper added before installation. Replacement yokes shipped from the factory will be marked 750192C to denote this wiring change. The recommended chassis circuit change must be made before the modified yoke is installed as a replacement.



**CBS-COLUMBIA** All chassis below 700-100 series

**Vertical retrace line elimination**  
(see Fig. 28).

To eliminate the vertical retrace lines, unground capacitor *C28* (connected to cathode of picture tube). Then, add the following parts: *C48*, a .01- $\mu\text{f}$ , 600-volt capacitor; *C49*, a .1- $\mu\text{f}$ , 600-volt capacitor, and *R46*, an 8,200-ohm, 1/2-watt,  $\pm 10\%$  resistor.

1. Connect *C49* (.1  $\mu\text{f}$  at 600 volts) in series with *C28* (.05  $\mu\text{f}$  at 600 volts) and the junction of the green lead of the vertical-output transformer (*T4*) and the brown lead of the deflection yoke (*L8A*).

2. Connect *R46* (8,200 ohms, 1/2 watt,  $\pm 10\%$ ) from the junction of *C28* and *C49* (step 1 above) to ground.

3. Connect *C48* (.01  $\mu\text{f}$  at 600 volts) from the junction of *C49*, *T4*, and *L8A* to ground.

The rewired circuit is shown in the figure.

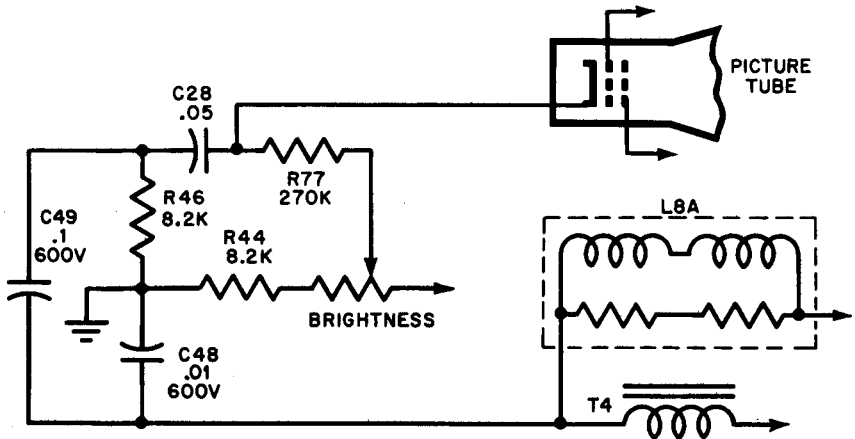

Fig. 28 — CBS-Columbia

**CBS-COLUMBIA 700-series chassis**  
**Double pulsing or moding**  
**of the picture.**

Double pulsing or moding of the picture has been reported on some 700-series chassis. This may be corrected by changing resistor *R60* in the horizontal sweep oscillator circuit from 270,000 ohms to 220,000 ohms.

**CBS-COLUMBIA 700-series chassis**  
**Picture overloading at certain**  
**contrast settings.**

In a few receivers of the 700 series, under certain transmitting conditions, it has been noted that the picture will overload at some settings of the contrast control. This can be corrected by making the following changes in the video-amplifier circuit:

1. Changing resistor *R69* from 2,200 ohms to 3,300 ohms.
2. Changing capacitor *C58* from 390  $\mu\mu\text{f}$  to 180  $\mu\mu\text{f}$ .

**CBS-COLUMBIA 700-series chassis**  
**Increasing range of focus control.**

Adjust the focus control on the rear apron of the chassis for the sharpest picture. If the focus control does not have sufficient range, you may correct this condition by adding or removing magnetic shunts. These shunts are available from the source. Adding shunts decreases the magnetic flux of the focus coil; removing them increases the magnetic flux. They should be adjusted until the focus control will be near the center of its range when the picture is in sharp focus, and centered with respect to the mask.

**CBS-COLUMBIA 700-series chassis**  
**Horizontal jitter.**

In cases of horizontal jitter in the 700 series, it will be found helpful if the following changes are made:

1. Change *R57*, in the plate circuit of the horizontal oscillator, from 3,900 ohms to 5,600 ohms.
2. Change *R58*, cathode resistor of the horizontal oscillator, from 2,700 ohms to 1,800 ohms.
3. Change *R60*, in the plate circuit of the horizontal oscillator, from 270,000 ohms to 220,000 ohms.
4. Change *C41*, connected from grid to ground of the horizontal oscillator, from .1  $\mu\text{f}$  to .05  $\mu\text{f}$ .

**CBS-COLUMBIA All chassis**  
**White coating on aquadag surface**  
**of picture tubes.**

It has been reported that a number of picture tubes in the field have developed a white insulating coating on the aquadag surface of picture tubes. This may be cleaned off by the following method:

1. Thoroughly wash off with plain warm running water.
2. Dry over an infra-red lamp or in warm circulating air, 120 degrees F (not over 140 degrees F).
3. Spray aquadag with clear *Krylon*, being careful to leave clear the spot at which the ground strap contacts the aquadag coating.

**CBS-COLUMBIA All chassis**  
**Arcing at high-voltage anode**  
**suction cup.**

Occasionally arcing may be experienced across the suction cup of

the high-voltage anode connector due to high humidity. The following remedy is suggested.

Remove the suction cup, cutting it off from the anode connector or stripping it back. Wash the glass area around the anode connector of the cathode-ray tube with soap and water, then clean the clear area around the high voltage socket with carbon tetrachloride. Spread the prongs of the anode connector sufficiently and reinsert into the picture tube, but leave off the suction cup. This cup is not required by the Underwriters Laboratories.



**CERTIFIED**                      **Model 49-10**  
**Centering focus-control adjustment.**

If focus control cannot be adjusted to point of best focus, proceed as follows:

Replace 2-meg resistor which is connected between focus and centering controls with a 1-meg resistor. This part is mounted on high-voltage distribution strip and is connected in series with a 1-meg resistor which goes to one side of the focus control.

**CERTIFIED**                      **Model 49-10**  
**Horizontal foldover.**

If the left side of the picture is cut off and seems to fold back on itself, or if, on a test pattern, the left side of the pattern is cut off and appears lighter than the rest of the picture, then proceed as follows:

Increase the value of the resistor which connects from one end of the high-voltage secondary of the high-voltage power transformer to ground. Replace the 250k-ohm resistor with a 500k-ohm or a 1-meg resistor.

This type of trouble may sometimes be eliminated by reducing the value of the grid resistor which connects from pin 1 of 6SN7 horizontal amplifier to ground. Replace the 2-meg resistor in that circuit with a 1-meg or 1.5-meg resistor. When making this change, check the results on a test pattern to make sure that the picture has not been distorted horizontally. See that both horizontal arms of the test pattern have the same length. Use that value of resistor which will reduce the foldover without introducing too much horizontal distortion of the picture.

**CERTIFIED**                      **Model 49-10**  
**Regeneration in sound i-f amplifier.**

If the set breaks into oscillation when sound i.f. and sound-sensitivity trimmer are adjusted for maximum sound, proceed as follows:

First make sure grid and plate leads on sound i-f transformer are as short as possible. Next connect a 22k-ohm resistor across the sound-sensitivity control instead of the 47k-ohm resistor in the original diagram. If the trouble remains after this is done, try a smaller value resistor. A smaller value resistor will improve the stability of the sound section of the receiver but will also decrease the gain. The best compromise should be used to give good stability without sacrificing too much gain.

**CERTIFIED**

**Model 49-10**

### Oscillator "spill over."

The oscillator may "spill over" when a station is tuned in to the resonant point with the fine-tuning control. This is due to the oscillator oscillating too strongly. The indication on the picture-tube screen is jagged vertical lines across the picture, accompanied by a rushing sound in the speaker.

To remedy this, replace the 47k-ohm oscillator grid resistor with a 22k-ohm resistor, or connect a 47k-ohm or 50k-ohm resistor in parallel with the 47k-ohm resistor originally in the circuit.

**CERTIFIED**

**Model 49-10**

### Horizontal tearing.

If picture tears horizontally, especially when contrast control is turned up, this means that the sync pulses are too strong and are overloading the sync amplifiers.

Replace 2k-ohm resistor in horizontal-oscillator grid circuit with a 500-ohm or 1,000-ohm resistor. Choose the resistor value which gives the best results.

Note: Horizontal-hold control should be adjusted on a weak picture with contrast control turned down. The picture should not tear horizontally as the contrast control is turned up to give a picture of average contrast. Turning the contrast control up too far will cause the picture to tear, but this is a normal condition and should not be confused with the trouble being dealt with here.



**CROSLEY**

**1949 Models,  
LD series**

### Improving contrast-control operation (see Fig. 29).

In some cases where these sets are operated in areas where the signals from one or more stations is exceptionally strong it may cause the contrast control to operate very critically. This condition can be corrected without losing sensitivity in the re-

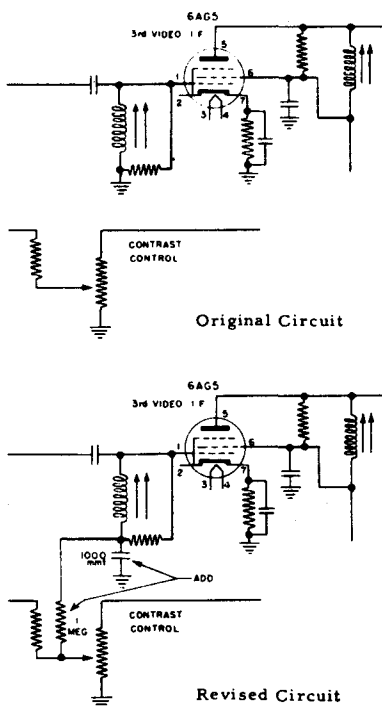

**Fig. 29 — Crosley**



ceiver by adding a variable bias to the third picture i-f stage. This can be accomplished by making the following wiring changes:

1. Disconnect the third i-f grid coil from ground.

2. Connect a 1,000- $\mu$ mf capacitor (part No. 160034) between the low side of the third i-f grid coil and ground.

3. Connect a 1-megohm resistor (part No. 39374-61) between the low side of the third i-f grid coil and center tap of the contrast control.

A schematic for this change is shown in the figure. If picture brightness fluctuation is still encountered due to line-voltage changes, disconnect the 470,000-ohm picture tube grid resistor from the cathode of the d-c restorer tube (6AL5) and connect the chassis.

## CROSLLEY

1950 Models

### Carrier buzz.

To reduce carrier buzz at high contrast settings on some sets, *C122* (in grid circuit of sound-detector driver, *V109*) may be changed from 100  $\mu$ mf, 500 volts (part No. C-137727-108) to 47  $\mu$ mf, 500 volts (part No. 137727-112). Resistor *R134* (also in grid circuit of *V109*) may be changed from 220,000 ohms,  $\frac{1}{2}$  watt (part No. 39373-80) to 47,000 ohms,  $\frac{1}{2}$  watt (part No. 39373-67). Also, *R138* (in plate circuit of *V109*) may be changed from 56,000 ohms, 1 watt, 10% (part No. 39374-134) to 27,000 ohms, 1 watt, 10% (part No. 39374-130).

This change will not show any great effect if the transmitting station is at fault, or the receiver is improperly aligned, or when receiver is operated at normal setting of the contrast control.

## CROSLLEY

1951 Models

### Repair of broken hinge (see Fig. 30).

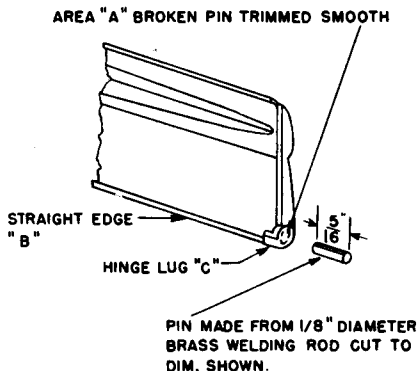

Fig. 30 — Crosley

When a broken hinge pin is encountered on the doors, repairs can easily be made in the following manner:

1. Trim off any remaining portion of the broken pin from area "A" (see sketch).
2. Heat a pin made of  $\frac{1}{8}$ -inch diameter brass welding rod, which is cut to a length of approximately  $\frac{5}{16}$  inch. The pin may be heated sufficiently with an electric soldering iron.
3. Carefully press one end of the heated pin against the center of area

"A" just long enough to permit the pin to melt its way into area "A". The pin must not be so hot that the heat destroys the paint or hinge lug "C".

4. Before the pin has a chance to cool, position it with respect to the straight edge "B" of the door and the length it protrudes from the door. This length should be approximately 3/16 inch.

5. After the pin has cooled and the plastic is hard enough to hold the pin securely, remove all burrs.

### **CROSLEY** 1951 Models **Reducing hum or buzz.**

To reduce hum or buzz, check the following:

1. Make certain that electrolytic capacitor *C120* has a good ground connection by soldering a wire from the chassis to one of the ground lugs on the capacitor. This should be done on all sets contacted in the field to prevent trouble developing as the set ages. Later production sets have the capacitor grounded in this manner.

2. Make certain that the sections of the electrolytic capacitor (*C120*) are properly connected as shown by the schematic.

3. If the shield in back of the contrast control has been removed, be sure to replace it.

4. On sets equipped with a resistor-capacitor unit (part No. W-149881), dress the coupling capacitor (*C122*) as far as possible away from the resistor-capacitor unit.

5. If necessary, remove the resistor *R141*.

6. Adjust the ratio-detector transformer (*T102*) secondary for minimum hum or buzz, while the set is tuned to the station. Only a slight adjustment is required. If the screw is turned too far, the result may be weak or distorted audio output.

7. Check over-all alignment according to the service information bulletin.

### **CROSLEY** 1951 Models **Fuse replacement.**

When it is necessary to replace the fuse in a 1951 television receiver, replace it with a 250-ma slow-blow type fuse (part No. 150431).

### **CROSLEY** 1951, 1952, 1953 Models

#### **Improving sync stability.**

To improve sync stability on the 1951, 1952 television receivers and chassis 380 of the 1953 receivers, change the resistor *R126* in the coupling circuit to the d-c restorer to a 15,000-ohm, 1/2-watt, 10% resistor (part No. 39374-39).

The 1953 line, chassis 380 coded C, is already equipped with the 15,000 ohm resistor.

### **CROSLEY** 1952 Models with 20- and 21-inch picture tubes

#### **Increasing range of focus control (see Fig. 31).**

If it becomes necessary to increase the range of the *Focus Control* on the 20- or 21-inch models of 1952, connect the focus coil (*L119*) as shown in sketch and explained below.

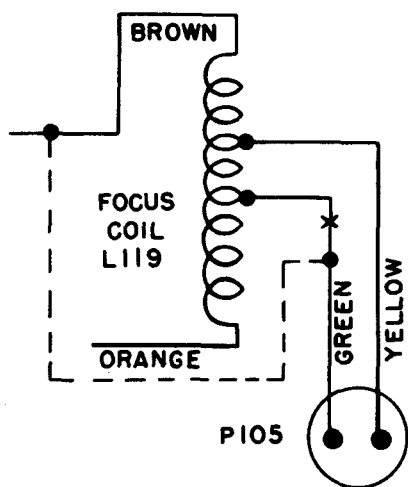

Fig. 31 — Crosley

1. Cut the green wire at X and tape the bare end of the portion of wire that remains on the focus coil. Be sure to allow enough wire to remain on the coil, just in case it is ever necessary to reconnect it in its original manner, if for any reason the picture tube must be replaced at a later date.

2. The portion of green wire that remains on P105 should be spliced to the brown wire of the focus coil as shown by the dotted line.

**CROSLEY** Models 10-401,  
10-404, 10-412, 10-414,  
10-416, 10-418

**Picture and sound separation.**

Picture and sound separation on the above models can be caused by a narrow band-pass of the i-f stages, narrow band-pass of the r-f tuner, or a combination of both. Check the i-f band-pass with a sweep generator, marker, and scope. The response

curve should appear as shown in the Model 10-401 service notes. Check r-f tuner by substituting for it with a unit that is known to be in good alignment.

**CROSLEY** Models 10-401,  
10-404, 10-412, 10-414,  
10-416, 10-418

**Neck shadow due to reversed focus coil.**

If trouble is experienced with the above models in centering the picture and reducing the neck shadow, it may be caused by reversed polarity of the focus coil. If this is suspected, the polarity can be changed by reversing the current through the coil. To do this, interchange the leads to the focus coil at the points where they are soldered under the chassis. Try centering the picture again. If the centering action is easier, the neck shadow diminished, and the angle the focus coil makes with the neck of the picture tube is nearer to a right angle, then this is the correct connection.

The reason for difficulty in centering when the focus coil polarity is incorrect, lies in the fact that the magnet field from the focus coil interacts unfavorably with the field from the ion trap. When the coil is connected correctly, the current flow will produce a north pole on that face of the coil nearest to the tube socket.

**CROSLEY** Models 10-401,  
10-404, 10-412, 10-414,  
10-416, 10-418

**Horizontal-oscillator drift.**

It has been found that on some receivers the horizontal oscillator ex-

hibits a tendency to drift. This causes the receiver to fall out of horizontal sync after operating several hours. If the horizontal-sync adjustment was made after the receiver has been operating for some time, the picture will not fall in sync when the receiver is cold. This trouble may be attributed to the .01- $\mu$ f capacitor *C160*, which is across the ringing coil of the horizontal-oscillator transformer, *T106*. This capacitor, if it is of the older molded type (type 487), may change capacitance, with temperature change, enough to cause the receiver to fall out of horizontal sync. To make correction, replace the .01- $\mu$ f molded capacitor *C160* with a .01- $\mu$ f, 600-volt paper type capacitor (part No. 39001-13). Then realign the trimmer at the bottom of *T106* in accordance with the service notes.

**CROSLEY** Models 10-401,  
10-402, 10-412, 10-418

**Horizontal-sweep sing**  
(see Fig. 32).

Horizontal-sweep sing can be caused by vibration of the mounting bracket on the horizontal-output transformer, *T107*. This mounting

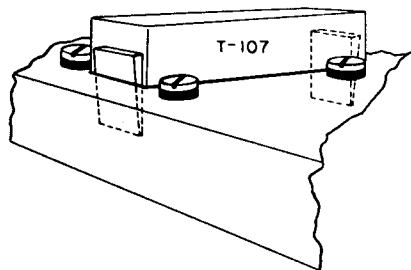

Fig. 32 — Crosley

bracket occasionally vibrates at a subharmonic of the 15,750-cps horizontal-sweep frequency. On later production sets this condition has been corrected by dipping the core and mounting bracket in a high melting point wax.

Receivers in the field that do not have this wax treatment can be corrected by inserting small wedges between each end of the transformer and the chassis as shown in the sketch. It is not necessary to remove the chassis from the cabinet to make this correction.

**CROSLEY** Models 10-401,  
10-404MU, 10-404MIU,  
10-412MU, 10-418MU,  
10-420MU

**Breakdown between leads.**

To prevent breakdown due to arcing between the plate leads of the horizontal-output tube (6BG6) and the damper tube, install 3½ inches of fiberglass sleeving (part No. 39468-14) over the 6BG8 plate lead. This sleeving should be placed toward the terminal on the horizontal-deflection transformer.

**CROSLEY** Models 10-414MU,  
10-416MU, 10-416MIU,  
10-429MU

**Increasing range of horizontal-hold control.**

Resistor *R151*, 150,000 ohms, ½ watt, 10% (part No. 39374-51) in the afc feedback circuit may be changed to 220,000 ohms, ½ watt, 10% (part No. 39374-53) to increase the range of the horizontal-hold control.

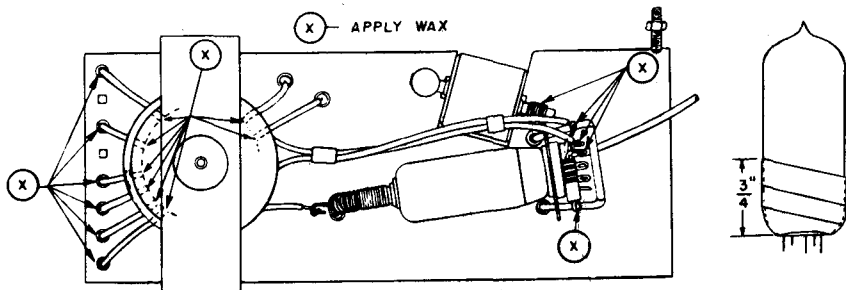

Fig. 33 — Crosley

**CROSLEY** Models 10-414MU,  
10-416MIU

**Preventing corona and arcing on high-voltage assembly (see Fig. 33).**

It is necessary to tape the 1X2 high-voltage rectifier tube in order to prevent corona on the outer surface of the glass. If the 1X2 tube is replaced by a new tube, apply poly-vinyl tape (part No. W-145717-2) as explained below and illustrated in the figure.

Wrap a strip of poly-vinyl electric tape,  $7\frac{1}{4}$  inches long and  $\frac{1}{2}$  inch wide, three times around the glass at the base of the tube. Begin at the point where the pins emerge and wrap spirally upward to a distance of approximately  $\frac{3}{4}$  inch above the base. Be certain the tape surface is smooth and free from wrinkles or sharp edges.

If corona or arcing is noticeable in the high-voltage assembly, do the following:

1. Inspect transformer leads where they leave the windings to be certain there is as much spacing as possible between adjacent leads.

2. Make certain that all the points indicated in the figure are completely covered with a high melting

point wax (part No. W-145727). This wax can be applied freely with a brush when melted. Do not heat above  $350^{\circ}$  F.

**CROSLEY** Models 10-419MU,  
10-427MU

**Increasing range of vertical-linearity control.**

To increase the range of the vertical-linearity control,  $R171$  in plate circuit of the vertical amplifier may be changed from a 4,700-ohm resistor to a 2,700-ohm, 1-watt, 10% resistor (part No. 39374-118), and resistor  $R169$  in the cathode circuit of the vertical amplifier may be changed from 2,700 ohms to 1,800 ohms.

**CROSLEY** Chassis 321, 321-1,  
-2, 331, 331-1, -2

**Increasing picture width.**

If it is necessary to increase the width of the picture beyond the range of the width control, remove the 15,000-ohm resistor ( $R214$ ) and connect a wire from lug 2 to lug 3 of the horizontal-output transformer ( $T107$ ). Also connect a 220- $\mu$ mf, 2,000-volt capacitor (part No. 137498-62) from lug 6 to lug 8 of the transformer.

**CROSLEY**Chassis 321-4,  
331-4**Correcting overloading of agc amplifier.**

To correct overloading of the agc amplifier in strong signal areas, the following changes are made: The 8,200-ohm resistor (*R218*) in the screen-grid circuit of the agc amplifier is deleted. The 155-volt +B is then connected directly to lug 6 of the agc amplifier socket (*V112*). The .002- $\mu$ f capacitor (*C181*) which was connected from ground to lug 6 of the *V112* socket is deleted.

**CROSLEY**Models with  
external agc adjustment**External agc adjustment.**

The agc adjustment, located at the rear of the receiver chassis, determines the voltage level at which the second detector operates. The set is adjusted to a strong signal. Therefore it should be reset, at the time of installation of the receiver, to the stations in the area in which the receiver will be used.

To set the agc adjustment properly, tune in the weakest station in the area and set the adjustment, by turning counterclockwise or clockwise, to a point where the picture just begins to overload with the contrast control set at maximum. When the adjustment is turned too far counterclockwise, the result may be low sensitivity (weak picture); if turned too far clockwise, the second detector may become overloaded. The result then may be an unstable picture on medium to strong signals.

If an overloaded picture is experienced on a strong-signal station after

the agc adjustment has been properly set, turn the contrast control toward minimum until the overload is eliminated. If the overload of the strong signal station cannot be controlled with the contrast control, it may be necessary to make a compromise adjustment between the weakest station and strong signal station with the agc adjustment.

**CROSLEY**Glass picture-tube  
models**Grounding picture tube.**

When replacing the picture tube, make certain that the grounding springs (attached to the deflection bracket) are long enough to make contact with the aquadag (external conductive coating on picture tube). If grounding springs are not long enough to make proper contact, fasten a new type grounding spring (part No. W-149671) to the side of the deflection bracket opposite the anode connector. This may be done with a self-threading screw, or by soldering.

**CROSLEY**Glass picture-tube  
models**Correcting arcing at second-anode terminal (see Fig. 34).**

It has been found that certain types of rubber anode caps gradually become conductive due to a chemical decomposition of the rubber, which is caused by the relatively high electrostatic stress present at the anode button. This produces a leakage path across the insulated area of the glass around the anode button and often results in corona or arcing problems.

Ordinarily, wiping the glass under the rubber cap does not remove the deposit that results from the breaking down of the rubber.

The suggested cure for this condition is to trim off the flange portion of the rubber cap to a point where no rubber touches the glass. This will leave only the sleeve portion of the cap which serves as a support for the lead into the connector.



ORIGINAL ANODE LEAD  
AND RUBBER CAP

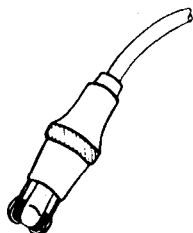

ANODE LEAD AFTER TRIMMING  
FLANGE PORTION OF RUBBER  
CAP.

Fig. 34 — Crosley

The cleaning of the glass around the anode button can be accomplished quite easily if ordinary water and a scouring compound such as *Bon Ami* are used. The area around the anode button should be scoured and then

thoroughly dried and polished with a clean dry cloth so that no residue remains. If the above instructions are carried out, no further trouble of this nature should be experienced.

#### CROSLEY Metal picture-tube models

##### Preventing arcing or corona on picture tube.

To retard the accumulation of dust collecting on the glass area behind the metal bell of the picture tube, this area was sprayed with silicon lacquer. In some cases this lacquer was hygroscopic, permitting moisture to be absorbed which resulted in corona or arcing. When this condition is experienced, thoroughly clean all the silicon lacquer from the tube with acetone.

#### CROSLEY All models Cleaning tuner unit.

It has been found that most r-f tuners which are weak, intermittent, or do not oscillate on the low channels, can be readily repaired by cleaning the *Inductuner* unit. In many cases the performance of the tuner can be restored to normal operation in the customer's home without removing the tuner from the chassis. Proceed as follows:

1. Remove the three *Inductuner* locknuts.
2. Remove the *Inductuner* cover.
3. Clean the spiral windings and the rotor contacts with clean carbon tetrachloride.
4. After thoroughly cleaning the unit, cover the contact surface of the spiral winding, rotor shaft and

swivel joint with a thin film of *Lub-Rex 100*.

5. Replace cover and locknuts.

Caution: Cleanliness is very important. Make sure the carbon tet and the lubricant is clean and free of all foreign substance. Use only a soft, clean nonmetallic applicator.

## **CROSLEY**

All models

### **Replacement of picture-tube base.**

When it is necessary to replace a broken base on the picture tube proceed as follows:

1. Remove the broken base by unsoldering all the pins, being careful not to damage the wires.

2. Straighten and form the wires so the new base (part No. 152026) can easily be placed on the wires.

3. Apply a coat of *General* speaker cement or equivalent to the glass neck of the tube and to the inside of the new base.

4. Place the new base on the tube, making certain that each wire is inside its proper pin. Hold the socket in place until the cement has dried sufficiently to permit soldering of the pins.

Note: A loose base can also be repaired in the field by applying cement between the glass and base.

## **CROSLEY**

All models

### **Reducing sweep radiation.**

To reduce sweep radiation which may interfere with radio reception proceed as follows:

1. With glass-type picture tubes, make sure that the tube has a good coating of aquadag. If the tube has

no coating, it may be necessary to replace the tube. If the aquadag is peeling or is missing from some portion where it is required, repair the aquadag with *Television Tube Coat No. 49-2*, manufactured by General Cement Mfg. Co. Also, be sure the aquadag is grounded to yoke with ground clip.

2. With *Scotch* tape, fasten one end of a sheet of aluminum foil (approximately 10" x 10") to the aquadag on the top area of the picture tube. Ground the other end of the foil under the tube strap.

3. Line the inside of the cabinet (area surrounding chassis) by cementing foil to the cabinet and grounding it to the sides of the chassis. Be sure to cut the foil away from any ventilation opening in the cabinet. In some cases it also may be necessary to place the foil completely across the chassis mounting shelf, underneath the chassis. After the cabinet is lined with foil the built-in antenna is no longer effective and should be grounded to the chassis. Therefore, it will be necessary to use either an external indoor or outdoor-type antenna.

4. Sometimes it may be necessary to make a shield out of copper screen, to fit over the horizontal-output and damper tubes.

## **CROSLEY**

Model DU-UHFP  
(UHF Converter)

### **Increasing sensitivity (see Fig. 35).**

Early production sets were wired according to schematic (A) shown in the figure. To increase the sensitivity on later production sets the



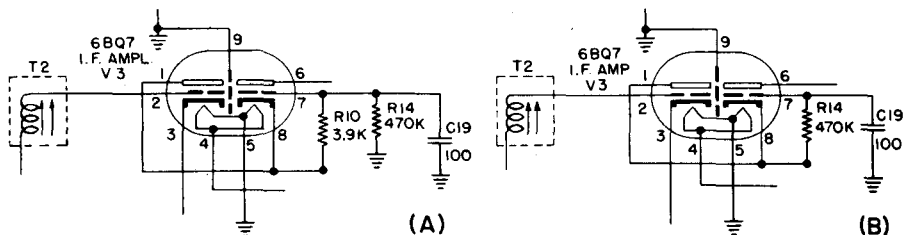

Fig. 35 — Crosley

resistor *R10* was deleted, and resistor *R14* was removed from chassis ground and wired between pins 7 and 8 of *V3* (6BQ7 tube). See schematic (B).

**CROSLLEY** Model DU-UHFP  
(UHF Converter)

**Reducing hum modulation.**

On later production sets, a capacitor *C18* (.005  $\mu\text{f}$ , 500 volts, 10% disc ceramic, part No. 144675-2) was added from pin number 7 of *V2* (6X4 tube) to chassis ground. This capacitor was added to reduce hum modulation on the uhf band caused by r-f carrier clipping in the power rectifier circuit. If it should become necessary to add this capacitor in early production sets, be sure to keep the leads as short as possible.



**DUMONT** Models RA-101,  
RA-102, RA-103

**Elimination of vertical jitter**

(see Fig. 36).

Some complaints of vertical jitter have been received in strong-signal areas and may occur even in areas

of moderate signal strength. Experience indicates that the following modification is effective in correcting this complaint:

1. Disconnect blue lead of vertical blocking oscillator transformer from +B supply point.
2. Disconnect red lead of vertical blocking oscillator transformer from end of integrator network and ground the red lead to the chassis.
3. Connect one terminal of a .01- $\mu\text{f}$ , 400-volt paper tubular capacitor to the point from which the red transformer lead was removed in step 2.
4. Connect blue transformer lead to the remaining lead of the .01- $\mu\text{f}$  capacitor.
5. Connect a 27,000-ohm, 2-watt carbon resistor: to the plate (pin 8) of the vertical-sync amplifier (*V6*) in model RA-101; to the plate (pin 2) of the sync clipper (*V16*) in model RA-102; to the plate (pin 5) of the vertical buffer (*V216A*) in model RA-103.
6. To the open end of the 27,000-ohm resistor, connect a 4,700-ohm, 1-watt carbon resistor and the positive terminal of an 8- $\mu\text{f}$ , 450v electrolytic capacitor.
7. Ground the negative terminal of the 8- $\mu\text{f}$  capacitor to the chassis.

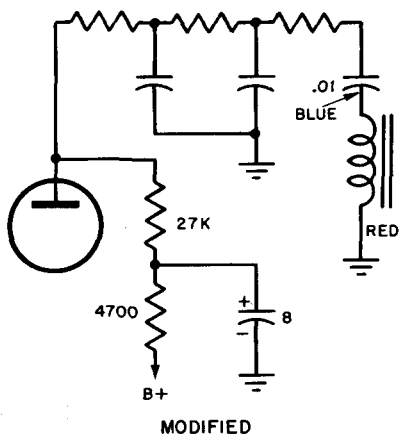
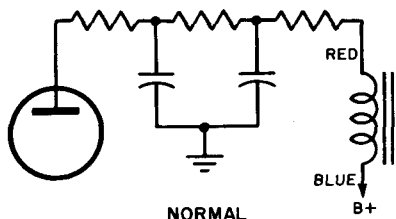

Fig. 36 — DuMont

8. Connect the open end of the 4,700-ohm resistor to the point from which the blue transformer lead was removed in step 1 (above).

9. In model RA-103, remove resistor *R270* (12,000 ohms) across one of the blocking oscillator transformer windings.

## DUMONT

Models RA-103,  
RA-103C

### Picture flicker.

Power-line voltage fluctuation can be the cause of flickering of the picture. (This appears similar to airplane caused flicker.) In a number of cases, flicker was found to be caused by a faulty installation or a bad 6AG5 in the video i-f strip. An undamped a-c voltmeter with a suit-

able range for measuring 117 volts can be used to check on the a-c line voltage. Once it has been established that fluctuating line voltage is causing the flicker, it is recommended that the following changes be made:

1. Connect a .5- $\mu$ f capacitor from the cathode of the picture tube (arm of potentiometer *R227*) to the junction of *R222*, *R223* and *C216B*.

2. On chassis which have not had the sync noise immunity change, disconnect *R219* from the junction of *R216*, *C215* and *R220*. Connect one end of a 27,000-ohm,  $\frac{1}{2}$ -watt resistor to the 12-volt line, a 8,200-ohm,  $\frac{1}{2}$ -watt resistor to ground, and a 25- $\mu$ f, 6-volt capacitor to ground. Connect the unconnected ends of these three components together and tie the disconnected end of *R219* to this junction.

This change will make a considerable reduction of the flicker for small amounts of line variation (well under one volt). For larger amounts of line variation, size fluctuation becomes as objectionable as brightness fluctuation and the only effective solution is to use a regulated transformer.

## DUMONT

Models RA-103,  
RA-103C

### Sync noise immunity (see Fig. 37).

In areas where the signal is weak and noise high, the noise may cause the loss of vertical sync. The following changes are recommended to reduce this effect:

1. Replace *V205*, the 6AC7 video amplifier, with a type 6AG7 tube as shown in the new vertical sync circuit, part (A) of figure.

2. Disconnect the low side of *R219*, the 4,700-ohm resistor in the grid circuit of *V205*, from the junction of *R216* and *R220*.

3. Connect a 12,000-ohm, 1/2-watt resistor from the low side of *R219* (just disconnected) to ground. Place a 25- $\mu$ f, 25-volt capacitor in parallel with this resistor. Connect the positive side of the capacitor to ground.

4. Add a 27,000-ohm, 1/2-watt resistor between the junction of *R219* and the 25- $\mu$ f capacitor and 12,000-ohm resistor added in step 3 and the junction of the -12.5 volt line and *R216*.

5. Remove *R223* (3,600 ohms) from the *V205* circuit, and replace with the two 6,800-ohm, 2 watt resistors connected in parallel. Connect one end of this combination to the low end of *L215* and run a lead from the other end of this combination to the junction of *R288*, the Focus Control, and *R286B*, the candohm strip resistor.

6. Remove *R222*, 3,300 ohms, connected to *C216B*.

7. Add a 1,800-ohm, 1/2-watt resistor from the junction of *L215*, *C217*, *L216*, and capacitor *C283*. (On early schematics this capacitor in the video circuit was wrongly noted as *C238*.)

8. Remove capacitor *C282*, connected from pin 7 of *V204B* to ground. Remove capacitor *C219*, located between pin 7 of *V204B* and pin 1 of *V212A*, and replace with a short lead, using the pin 7 lug to which *C219* was connected.

9. Remove resistor *R224*, located between pin 1 of *V212A* and ground.

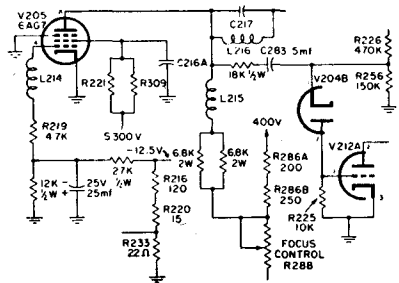

NEW VERTICAL SYNC CIRCUIT (A)

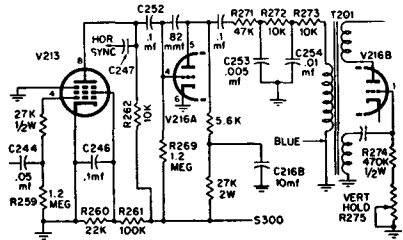

NEW HORIZONTAL SYNC CIRCUIT (B)

Fig. 37 — DuMont

For the following steps refer to the new horizontal sync circuit, part (B) of figure.

10. Add a 27,000-ohm, 1/2-watt resistor from the junction of *C244* and *R259* to pin 4 of *V213*.

11. Change the value of capacitor *C252* (from pin 8 of *V213* to pin 4 of *V216A*) to .1  $\mu$ f.

12. Disconnect the ground side of *R269*, in the grid circuit of *V216A*. This will be connected in step 17.

13. Connect an 82- $\mu$ f capacitor between pins 4 and 5 of *V216A*.

14. Disconnect *R271*, 10,000 ohms, from pin 5 of *V216A*. This resistor will be replaced in step 18.

15. Connect a 5,600 ohms, 1/2-watt resistor to pin 5 of *V216A*.

16. Connect the other end of the 5,600-ohm resistor just added to a

27,000 ohm, 2-watt resistor. Run a lead from the junction of these two resistors to *C216B*.

17. The other end of the 27,000-ohm resistor is to be connected to the junction of *R262* and *R261* and to the low side of *R269* (the 1.2-megohm resistor in the grid circuit of *V216A*).

18. Replace *R271* with a 47,000-ohm, 1/2-watt resistor.

19. Connect a .1- $\mu$ f capacitor between pin 5 of *V216A* and 47,000-ohm resistor just added.

20. Disconnect the blue lead of the primary of *T201* from the +175 volt line and run directly to ground.

**DUMONT** Models RA-103,  
RA-105

**Improving signal-handling ability.**

To improve the signal-handling ability of the *Inputuners* used in these receivers, the screen bypass capacitor *C110*, in the 6AK5 mixer circuit, may be changed to a minimum value of 5,000  $\mu\mu$ f at 600 volts. Later production runs have this change made.

**DUMONT** Models RA-103D,  
RA-104A, RA-105B, RA-108A,  
RA-110A

**Microphonic oscillator tube.**

Some field complaints have been registered because the 6AB4 oscillator tube in the *Inputuner* has become microphonic. If a microphonic condition occurs (this is evident if the sound howls when the volume is turned up, or if a noise is heard in the speaker as the set is tuned) it is suggested that the following procedure be followed:

1. Reverse the loudspeaker leads.
2. Replace the 6AB4.

**DUMONT** Models RA-103D,  
RA-104A, RA-108A, RA-110A

**Insufficient high voltage.**

High voltage may be low or absent. A check of the high-voltage section shows all components to be in order.

The stand-off insulator for the corona shield may become carbonized. It is wise to check this insulator before attempting to troubleshoot the high-voltage section. One of these insulators may become cracked when the screw holding it to the shield is drawn too tight. Moisture enters the crack and produces high-voltage leakage, which eventually carbonizes the insulator and results in the condition described above.

Replace the defective insulator, taking care not to tighten the screw excessively.

**DUMONT** Models RA-103D,  
RA-104A, RA-110A

**Jerky tuning action.**

When the receiver is tuned, the dial pointer may jump across sections of the dial, making it difficult to tune at some points. The tuning mechanism on these receivers incorporates an idler wheel of small diameter which rides on top of the large cam as the cam is rotated. Observation of this idler shows that it is rising off the cam, making poor contact when the tuning knob is rotated. Proper pointer action requires that the idler be on the cam at all times.

## PARTS LIST

Ref. No.	New Part No.	Description
C217	03014770	.1 $\mu$ f, 400v, 20%
C218	03019120	.047 $\mu$ f, 400v, 20%
C221	03014820	.1 $\mu$ f, 600v, 20%
C244	03019110	.047 $\mu$ f, 200v, 20%
C257	03019130	.1 $\mu$ f, 400v, 10%
C258	03014770	.1 $\mu$ f, 400v, 20%
C263	03014910	.01 $\mu$ f, 400v, 20%
C275		Same as C257
C276		Same as C217

The dial cord, although originally installed with the proper tension, tends to tighten as it ages, pulling the idler away from the cam. Lessen the tension of the dial-cord spring, a little at a time, checking the action of the idler and the cam. When the idler stops rising while the cam is being rotated, the adjustment is correct.

**DUMONT** Models RA-103D,  
RA-104A, RA-110A

**Reducing shock hazard between chassis and ground.**

To reduce shock hazard between chassis and ground, the value of the line-filter capacitors, C260 and C261, may be changed from .05  $\mu$ f at 600 volts to .02  $\mu$ f at 600 volts. Later production runs included this change.

**DUMONT** Models RA-103D,  
RA-104A, RA-110A

**Preventing volume control from becoming noisy.**

Capacitor C312, .05  $\mu$ f at 200 volts (part No. 03000950), may be added between S202, section 2 rear, terminal 10, and the R246 (volume control). This will remove the d-c component of the discriminator output from the volume control in order to prevent the control from becoming noisy.

**DUMONT** Models RA-103D,  
RA-104A, RA-110A

**Preventing possible capacitor failure.**

To eliminate possible failure of certain capacitors under humid conditions, some critical paper-cased capacitors may be replaced by the plastic-molded capacitors listed above.

**DUMONT** Models RA-103D,  
RA-104A, RA-110A

**Channel 7 beat elimination**  
(see Fig. 38).

Separate from the complaints of channel 5 regeneration and all-channel regeneration, complaints of a beat on channel 7 have been received. This

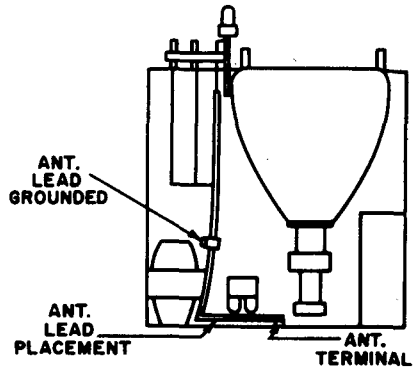

Fig. 38 — DuMont

beat does not exhibit itself in the form of diagonal black lines. Instead, the indications consist of black streaks running horizontally through the picture when the set is tuned "on the nose" to channel 7. This condition is caused by the eighth harmonic (175.2 mc) of the sound i.f. (21.9 mc) beating with the video carrier of channel 7 (175.25 mc).

To correct this condition, it has been found that placing the antenna lead to the tuner as shown in the figure, is very effective. Another remedy is to ground the antenna lead one-half way back from the tuner to the antenna terminal on rear of chassis. Should neither of the above changes correct this condition, the sound-discriminator transformer should be slightly detuned.

**DUMONT** Models RA-103D,  
RA-104A, RA-110A

**Elimination of vertical jitter**  
(see Fig. 39).

To eliminate vertical bounce or jitter, especially in strong-signal areas, proceed exactly as described to eliminate vertical jitter for DuMont Models RA-105B, RA-108A. In addition to the four steps described, proceed as follows:

5. Remove capacitor *C303* and resistor *R344* from plate circuit of *V216A*.

6. Connect plate of vertical buffer (pin 5) directly to *R272*.

**DUMONT** Models RA-103D,  
RA-104A, RA-110A

**Increasing gain.**

To obtain increased gain in the video i-f stages, the 6AG5's ( $G_m =$

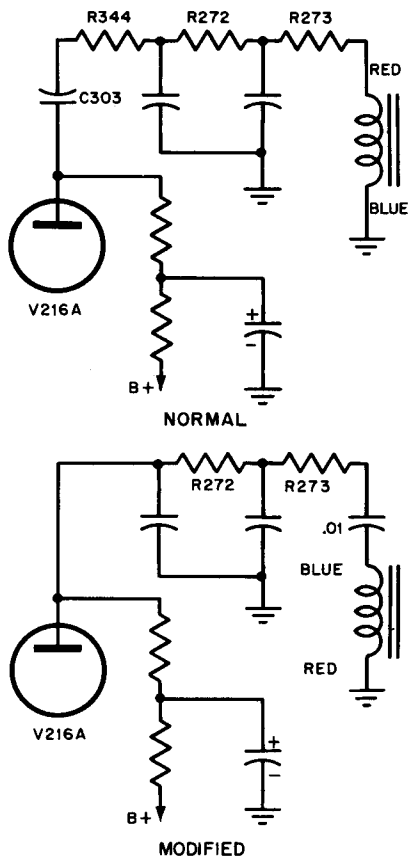

Fig. 39 — DuMont

5,000) may be replaced by 6BC5's ( $G_m = 6,000$ ). If the third video i-f stage (*V203*, 6AG5) is replaced by a 6BC5, change the screen-grid capacitor, *C213*, from  $.005 \mu\text{f}$  to  $470 \mu\mu\text{f}$  at 600 volts (part No. 03016480).

**DUMONT** Models RA-104A,  
RA-110A

**Barkhausen oscillations.**

The condition known as barkhausen oscillation has appeared on a

number of RA-104A and RA-110A sets. The indication of this trouble is one or more vertical black lines on the left-hand side of the raster. To eliminate this condition, take the following steps:

1. Use only coax transmission line. Use RG-11/U in the fringe areas and RG-59/U in strong-signal areas.

2. Make sure the shield of the coax is properly grounded to the antenna connector shield.

3. Keep the coax transmission line away from the power-supply chassis.

4. Place a metal plate (preferably copper) under the power-supply chassis and main chassis. This plate need only be large enough to act as a bond between the two chassis.

5. If the above steps do not cure the condition, replace the 6BG6. Also ascertain that the drive control is properly adjusted.

**DUMONT Models RA-105, RA-106**

**Reducing picture flicker.**

To reduce flicker the following changes may be made in the RA-105, RA-106 main chassis. The flicker referred to results from periodic line voltage fluctuations such as are produced by reciprocating pumps and similar devices. This change is sometimes referred to as an "anti-flicker circuit."

Pins 6 and 7 on V206-B, the d-c restorer tube, are removed from ground. Pins 6 and 7 on V206-B are connected together and a lead is run from pin 6 of V206-B to pin 8 of V207, thus returning the d-c restorer to the cathode of the third video am-

plifier instead of to ground. Capacitor C224 is changed from .1  $\mu$ f, 200 volts,  $\pm 25\%$ , to .5  $\mu$ f, 400 volts,  $\pm 25\%$ . The part number of the new capacitor is 03014260. Capacitor C224 is connected between pin 11 of the cathode-ray tube and the junction of R235 and C220A. Resistor R347, 470 ohms, 1 watt, 10% (part No. 02034730) is connected in series between R232 and R321.

**DUMONT Models RA-105, RA-106**

**Adjacent-channel interference (see Fig. 40).**

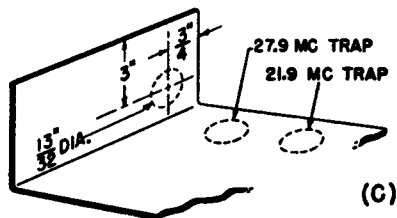
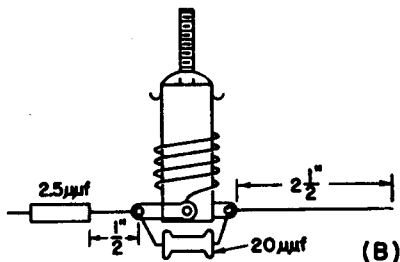
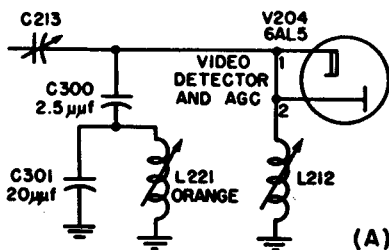

Fig. 40 — DuMont

In certain areas where television signals are received on two adjacent channels (such as halfway between two cities having television stations) adjacent channel video interference may occur. When tuned to the lower frequency of two such adjacent channels, interference is experienced from the higher frequency channel. This interference is usually seen as horizontal sync running back and forth through the desired signal.

This may be corrected by the addition of a series-parallel resonant trap in the third video i-f amplifier as illustrated in part (A) of the figure. The latest RA-105 and RA-106 chassis include this trap.

The trap will be tuned to 20.4 mc. This 20.4 mc is obtained when the local oscillator beats with the video carrier of the channel above the desired channel. Consider a location where both channel 5 and channel 6 can be received. With the set tuned to channel 5, 76-82 mc, the local oscillator is tuned to 77.25 mc (video carrier of channel 5) plus 26.4 mc or 103.65 mc. The local oscillator signal also beats with the video carrier of channel 6 (83.25 mc) and produces a frequency equal to the difference between 103.65 mc and 83.25 mc which is 20.4 mc.

The parts used are as follows:

Connect the 2.5- $\mu\text{mf}$  capacitor to the lug to which the end of the winding closest to the lug is soldered, leaving  $\frac{1}{2}$  inch of wire between the body of the capacitor and the lug. Connect a  $2\frac{1}{2}$  inch length of #18 bare-tinned copper wire to the other lug of the inductor. Connect the 20- $\mu\text{mf}$  capacitor across both of the lugs of the inductor, as shown in part (B) of the figure.

Carefully enlarge the "keyhole" to  $\frac{13}{32}$  inch diameter, in the video i-f amplifier shield plate, using a *Parker-Kalon* metal punch XX (see part (C) of the figure). Use extreme caution when punching this hole so that alignment will not be disturbed. Insert the trap assembly in the hole so that the lugs are parallel to the main chassis, and with the bare wire away from the main chassis. Solder the bare-tinned wire to the ground lug directly beneath on the main chassis. Solder the free end of the 2.5- $\mu\text{mf}$  capacitor to the junction of L212, C213, and pins 1 and 2 of V204.

The trap may be tuned, using a signal generator or by utilizing the interfering station.

1. Setting the trap by signal generator: Turn the contrast control to the extreme right. Connect a signal generator, 30% modulated at a carrier frequency of 20.4 mc, to pin 1 (grid) of V201 and chassis. Con-

#### PARTS LIST

Ref. No.	Part No.	Description
C300	03002720	Capacitor, ceramic, 2.5 $\mu\text{mf}$ , $\pm 0.5 \mu\text{mf}$ , 500v
C301	03013800	Capacitor, ceramic, 20 $\mu\text{mf}$ , $\pm 5\%$ , 500v
L221	21003971	Variable inductance



nect an oscilloscope between pin 4 (grid) of *V205* and ground. Adjust coil for minimum deflection of the oscillograph.

2. Setting trap using two adjacent stations: Tune receiver to sound of lower channel. Adjust contrast and watch for the interference. Tune trap from maximum inductance toward minimum inductance until the interference disappears. Rock trap tuning back and forth to be certain that the trap is correctly set.

**DUMONT** Models RA-105B, RA-108A

**Rectifier-tube filament unlit.**

One trouble that has been encountered in these sets that may be confusing to the serviceman is a condition wherein the filaments of the 5U4G rectifiers do not light. If a short on the secondary of the regulating transformer should develop, this will cause the voltage of the 5U4G's, which incidentally, is also regulated, to drop very low, and thus give the appearance that the 5U4G's are not lit. If this should occur, an investigation of the .05- $\mu$ f capacitor connected from the cathode of the 5U4G should be made. Another possible cause of a short is the wire going to capacitor C302 which is located on the side of the main chassis. If replacement of this capacitor or transformer becomes necessary, not only should the part number be specified in obtaining a replacement, but the color dot on the transformer and/or capacitor should be indicated. There are three different colors used: red, yellow, and white. Thus, a capacitor with a red dot should be used with a transformer having a red dot.

**DUMONT** Models RA-105B, RA-108A

**Correcting vertical jitter**  
(see Fig. 41).

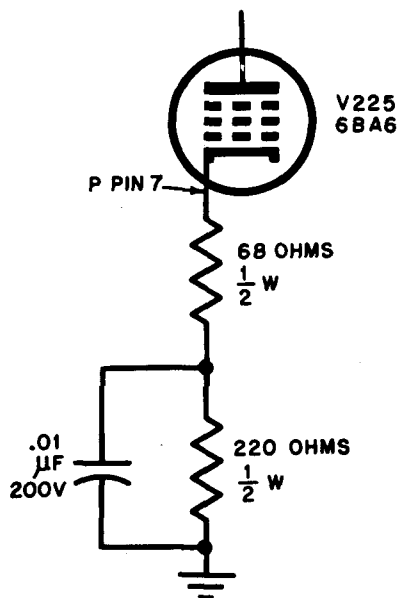

Fig. 41 — DuMont

Intermittent vertical jitter has been observed in the field in certain areas on some RA-105 and RA-108 models. This has been caused by compression of the sync signals in the narrow-band sync amplifier chassis. To correct this condition, it is suggested that the following changes be made in the narrow-band sync circuit:

1. *V225* should be changed from a 6AU6 to a 6BA6.
2. Resistor *R363*, located in the small narrow-band sync chassis should be changed from 22k, 1/2w to 15k, 1/2w.
3. Remove resistor *R356*, the 100-ohm, 1/2-watt resistor connected be-

tween pin 7 and ground on the 6AU6. This resistor should be replaced with a 68-ohm,  $\frac{1}{2}$ -watt resistor in series with a 220-ohm,  $\frac{1}{2}$ -watt resistor, by-passed by a .01- $\mu$ f capacitor. This combination should be connected between pin 7 and ground of V225 as shown on the sketch.

The narrow-band amplifier must be realigned after this change.

**DUMONT** Models RA-105B, RA-108A

**Elimination of vertical jitter**  
(see Fig. 42).

Vertical jitter may occur in strong-signal areas or even in areas of moderate signal strength. Experience indicates that the following modification is effective in correcting this complaint:

1. Disconnect blue lead of vertical blocking oscillator transformer (T201) from chassis ground.
2. Disconnect red lead of vertical blocking oscillator transformer (T201) from end of integrator network and ground red lead to chassis.
3. Connect one terminal of a .01- $\mu$ f, 450-volt paper tubular capacitor to the point from which the red transformer lead was removed in step 2 (above).
4. Connect blue transformer lead to the remaining lead of the .01- $\mu$ f capacitor.

**DUMONT** Models RA-108A, RA-110A

**Preventing "thumping."**

An interesting phenomenon which could be the source of some annoyance has occurred in sets using

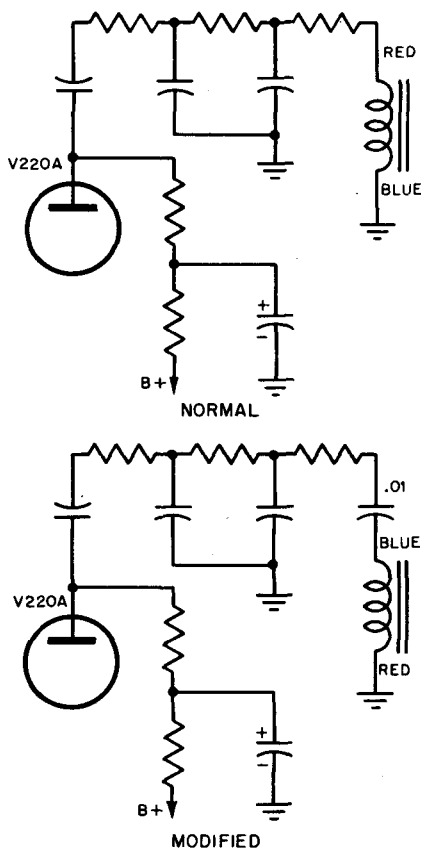

Fig. 42 — DuMont

the 19AP4 metal picture tube. This condition may be described as an "electrostatic pendulum." The "pendulum" consists of a swinging back and forth, in a definite rhythm, of the tag tied to the high-voltage lead. This warning tag makes a resounding "thump" each time it strikes the metal. When installing the set, the position of the tag should be noted to prevent this condition occurring.

**DUMONT**

Model RA-109  
series, RA-111  
series

**Improvement of sensitivity.**

In certain fringe areas, it has been found necessary to resort to certain simple changes to improve the sensitivity or signal-to-noise ratio of the receivers. It is suggested that the following changes be made in the order shown if low sensitivity or low signal-to-noise ratio is encountered.

1. Replace the first and second video i-f tubes (6AU6) with 6BC5's.
2. Replace the fourth video i-f tube (6AU6) with a 6BC5.
3. Remove the ground connection from pin 2 of the fourth video i-f tube socket.
4. Replace last i-f transformer (Z209 in model RA-109 or Z208 in RA-111) with a new transformer, part No. 20005241.
5. Realign stage as per manufacturer's instructions.

**DUMONT**

Models RA-109  
series, RA-119A

**Snow in picture.**

If snow is evident on weak signals, change resistor R-355 connected to the plate of the agc clamp stage (pin 5 of V-227B, 6SN7), from 10 meg to 3.2 meg, 1/2 watt.

Note: Later production chassis incorporate this change.

**DUMONT**

Model RA-109  
series

**Reducing horizontal instability**

(see Fig. 43).

A few complaints have been received concerning horizontal instability which displays itself as horizontal

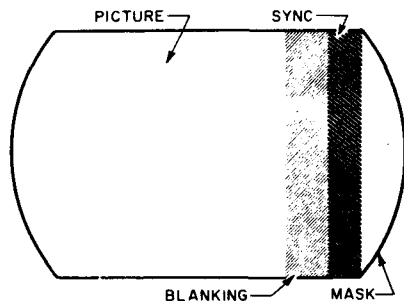

Fig. 43 — DuMont

wobble or jitter of the picture. A solution of this problem is to adhere to the following adjustment procedure:

1. Move the raster to the left so that the right edge can be seen.
2. Tune to a station, preferably the one producing the wobble.
3. Remove the sync clipper, V218, and adjust the horizontal-frequency control (rear slug of Z211) so that the picture is as near in horizontal sync as possible. (With V218 removed the picture will be out of sync both horizontally and vertically.)
4. Replace V218 and adjust the phasing slug (front) of Z211 so that the picture moves to the left in the raster. Continue adjusting this control until the wobble stops. At the point where the wobble stops there should be approximately 1/2 inch of sync visible on the right side. Both blanking and sync will be visible on the right when the brightness and contrast controls are adjusted to show this (see the figure).
5. Remove V218 again and re-adjust the horizontal-frequency control, as prescribed above, to as near sync as possible.
6. Replace V218 and re-adjust the phasing control until the wobble dis-

appears. Switch back and forth from television to FM positions. If the picture does not pull into horizontal sync when switched to television, readjust the horizontal-frequency control slightly to overcome this condition.

**DUMONT** Models RA-107 series

**Repair of horizontal-output transformer.**

If the high-voltage coil of the horizontal-output transformer (T-206) becomes defective, it is not necessary to replace the complete transformer. Replacement high-voltage coils are available (part No. 20005721) from the manufacturer. Complete installation instructions are included with the part.

**DUMONT** Model RA-109 series

**Preventing breakdown of R238.**

The 68,000-ohm screen-dropping resistor (R238) of the first video i-f stage (pin 6 of V208, 6AU6), was changed from a 1/2-watt unit to a 1-watt unit in later production to prevent breakdown due to overheating. Whenever these receivers are serviced, it is advisable to make the change to prevent future service calls.

Note: Chassis with serial numbers of 0949049 and higher incorporate this change.

**DUMONT** Model RA-109A, RA-111 series

**Video i-f bandwidth adjustment.**

If difficulty is encountered in obtaining the proper i-f response

curves during alignment, it is possible that the coupling capacitor inside the associated video i-f transformer may require adjustment. These capacitors take the form of a wire protruding from the bottom of these video i-f transformers which fits into a sleeve inside. They are preset at the factory during alignment for proper bandwidth and are sealed in place with *Miracle Adhesive*, C2M55. In order to readjust the coupling, the wire protruding from the bottom of the transformer should be heated with a soldering iron to soften the adhesive. Once the wire is free, the heat may be removed and the wire slid in (for increased bandwidth) or out (for decreased bandwidth) of the sleeve to adjust for proper bandwidth. The wire should then be sealed in place with *Miracle Adhesive*, C2M55.

Under normal circumstances it will not be necessary to readjust these coupling capacitors and it is recommended that they not be tampered with unless a test with a sweep generator and oscilloscope definitely indicates improper bandwidth.

**DUMONT** Models RA-109A, RA-111A

**Increasing high-channel sensitivity (see Fig. 44).**

A few field complaints have been received indicating that the high-channel sensitivity of the receiver is low in certain areas, as a result of low oscillator-injection voltage. If this condition should be encountered it is suggested that the following procedure be followed to improve the sensitivity:

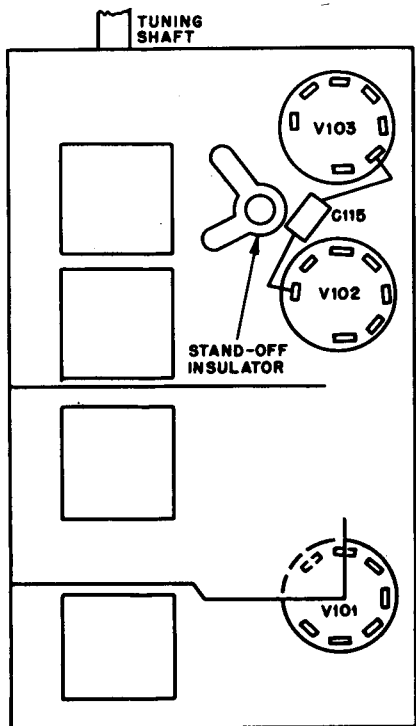

Fig. 44 — DuMont

Remove the *Inputuner* and dress capacitor *C115* as far away from the bottom of the *Inputuner* chassis (not bottom plate) as possible and close to the stand-off insulator mounted between *V102* (6AK5) and *V103* (6AB4) (see the figure). Care should be exercised not to disturb the position of other components in the *Inputuner* while redressing *C115*.

**DUMONT Model RA-109A**  
**Background hum in sound.**

To eliminate background hum in sound, remove heater choke *L209* (part No. 21005601) and connect heater line directly.

**DUMONT Model RA-109A**  
**Improving high-frequency tone quality.**

To improve the high-frequency tone quality, proceed as follows:

1. Delete capacitor *C315*, 220  $\mu\mu\text{f}$ , connected across part of *R221* (volume control).
2. Change value of *C215* (at output of sound discriminator) from 470  $\mu\mu\text{f}$  to 680  $\mu\mu\text{f}$ .

**DUMONT Model RA-109A**  
**Elimination of channel 7 beat**  
(see Fig. 45).

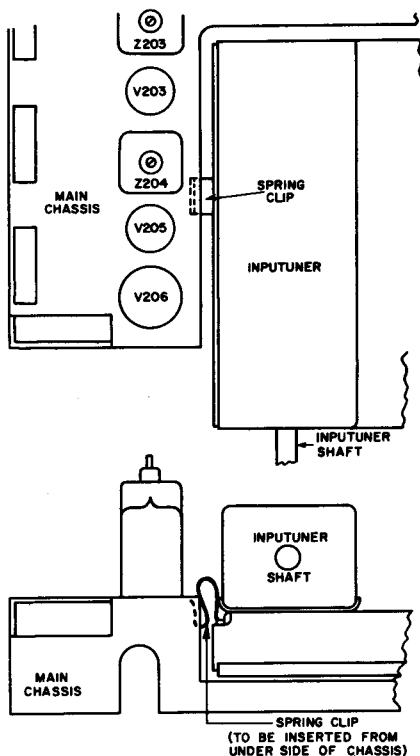

Fig. 45 — DuMont

A few complaints of an annoying beat on channel 7 in model RA-109A have been received. This interference is the result of the eighth harmonic (175.2 mc) of the sound i.f. (21.9 mc) beating against the video carrier (175.25 mc) of channel 7 and thus producing a 50-kc beat. This beat shows up in the picture as black horizontal streaks.

A single circuit change is necessary to eliminate this condition and should be made as follows:

1. Tune the RA-109A accurately to channel 7 using the tuning indicator.

2. With the receiver properly tuned, remove the a-c plug from the receiver.

3. Without disturbing the tuning, remove capacitor *C213*. This is the 47- $\mu\text{f}$  r-f by-pass capacitor connected between pin 5 and ground of *V204* (the 6AL5 discriminator).

4. Replace the a-c plug in the receiver. As soon as the set becomes operative, it will be noticed that the tuning indicator shows the set to be improperly tuned. Do not attempt to correct by retuning the receiver.

5. To realign the discriminator, merely turn the top slug of the discriminator transformer until the tuning eye indicates correct tuning. This usually requires about  $\frac{1}{4}$  turn of the slug.

In addition, a spring clip, part No. 30015401, should be inserted between the *Inputuner* and the chassis as shown in the illustration.

These changes are already made in chassis beginning with serial No. 0915725.

## **DUMONT** Model RA-109A

### **Improvement of vertical linearity.**

Resistor *R300* (cathode resistor of *V220*) is changed from 1,000 ohms, 1 watt, 10% to 560 ohms,  $\frac{1}{2}$  watt, 10% to improve the vertical linearity. This change has been made in later production runs.

## **DUMONT** Model RA-109A

### **Preventing background rumble.**

To eliminate an audible background rumble, capacitor *C266* (used in negative voltage supply across *R309*) is changed from .1  $\mu\text{f}$ , 200 volts to 25  $\mu\text{f}$ , 25 volts. The new part No. is 03015310.

## **DUMONT** Model RA-109A

### **Breakdown between chassis and flyback-transformer lead.**

In order to eliminate electrical breakdown between chassis and the white-red wire from the flyback transformer (*T-206-6*), the following change is made: The white-red wire from *T-206-6* to the capacitor end of the clip on *V230* is removed and replaced with a white wire to the tube end of the clip on *V230*. This change has been incorporated in later production runs.

## **DUMONT** Model RA-109A

### **Improving interlace.**

To improve the interlace, resistor *R297*, connected to pin 3 of *V220* is changed from 4,300 ohms,  $\frac{1}{2}$  watt, 5% to 2,700 ohms,  $\frac{1}{2}$  watt, 5%. The new part No. is 02030580. The vertical-hold control should be very carefully adjusted for best interlace.

**DUMONT Model RA-109A****Producing larger deflection in tuning indicator.**

The following changes are made in order to give a larger deflection in the tuning indicator:

1. Resistor *R212* (screen of *V203*) is changed from 1k, 1/2w, 10% to 22k, 1/2w, 10%. It should be disconnected from the 85-volt line and reconnected to the 150-volt line.

2. Delete *C316*, 5- $\mu$ f capacitor in grid circuit of first sound i-f amplifier, and make a direct connection between *Z201*-(3) and pin 1, *V201*.

3. Delete *C314*, 10- $\mu$ f capacitor in grid circuit of second sound i-f amplifier, and make a direct connection between *Z202*-(3) and pin 1, *V202*.

4. Disconnect the ground end of *C204* (plate by-pass of *V201*) and reconnect to pin 6, *V201*.

5. Disconnect the ground end of *C207* (plate by-pass of *V202*) and reconnect to pin 6, *V202*. This change was incorporated in later production runs of this model.

**DUMONT Model RA-109A****Rewiring of fuse (see Fig. 46).**

The wiring of fuse *F202* may be changed to prevent frequent fuse failure. The wiring change eliminates an a-c component of current from *F202* which is operating close to its rated value. Care should be taken to include only the connection to the plates of *V232* and *V233* at B; all other 338-volt leads going to A.

**DUMONT Model RA-109A****Improving sound attenuation.**

New coupling capacitor *C304* (part No. 03016896) from output of

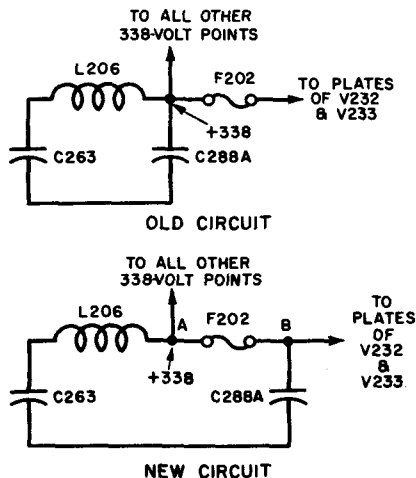

Fig. 46 — DuMont

mixer to be installed above chassis. Capacitor leads, which connect to same terminals as before, pass through holes adjacent to *Z206* and *Z207*.

**DUMONT Model RA-109A****Reducing high-frequency distortion.**

To reduce high-frequency distortion in sound output, proceed as follows:

1. Connect capacitor *C327* (part No. 03018650), .002  $\mu$ f at 600 volts, across pins 3 and 4 of *V207*, the third sound amplifier.

2. Connect resistor *R376* (part No. 02032010), 100,000 ohms, 1/2 watt, 10%, across *C218* (in bass-compensation network connected to tap on volume control) to ground.

**DUMONT Model RA-109A****Interchange of first and second sound amplifiers.**

To minimize the possibility of short circuits occurring in the first

and second sound amplifiers due to component placement and lead dress, interchange the pin numbers of the first and second sound amplifiers (12AU7, V206A and V206B). The wiring should be as follows:

*1st Sound Amp., V206A*

- Plate — pin 6
- Grid — pin 7
- Cathode — pin 8

*2nd Sound Amp., V206B*

- Plate — pin 1
- Grid — pin 2
- Cathode — pin 3

**DUMONT** Model RA-111 series

**Regeneration in video i.f.**  
(see Fig. 47).

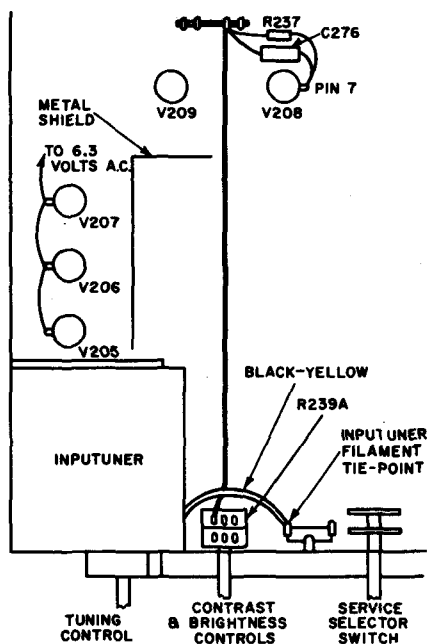

Fig. 47 — DuMont

If the receiver is modified to improve its sensitivity in fringe areas, it is possible that regeneration may occur in the video i-f amplifiers. To avoid this, proceed as follows:

1. Add a 68,000-ohm,  $\frac{1}{2}$ -watt resistor across terminals 1 and 2 of Z208 (last i-f transformer).

2. Remove the 5,000- $\mu$ f capacitor from pin 4 (heater) of V203 (6T8), if one is present. Connect the 5,000- $\mu$ f capacitor from the ungrounded side of the heater of V207 (third video i.f.) to ground. The part No. of this capacitor is 03015610.

3. Redress and shorten lead from junction of R237, C276 (cathode circuit of video amplifier, V210) to contrast control, R239A, as shown in the accompanying sketch. Keep this lead away from the Inputuner.

4. Disconnect heater lead from V205 (first video i.f.) which runs to filament tie-point of Inputuner (located near front of chassis between the service selector switch and the contrast control). Reconnect the heaters of V205 and V206 to the 6.3-volt a-c line by connecting a lead from the ungrounded side of heater of V206 (second video i.f.) to the ungrounded side of the heater of V207 (third video i.f.) as shown in the accompanying sketch.

**DUMONT** Model RA-111A  
**Improving horizontal linearity.**

In order to improve the horizontal linearity by eliminating the packing on the right side of the picture, change capacitor C251 (pin 8, V215) from .005  $\mu$ f, 600 volts, 25% to .05  $\mu$ f, 400 volts, 25% (part No. 03014020).



## DUMONT Model RA-111A

### Fuse replacement.

Any serviceman having difficulty with the 3-ampere line fuses blowing should replace with a 4-ampere fuse (part No. 11000800).

## DUMONT Model RA-111A

### Installation of Local-Distance switch (see Fig. 48).

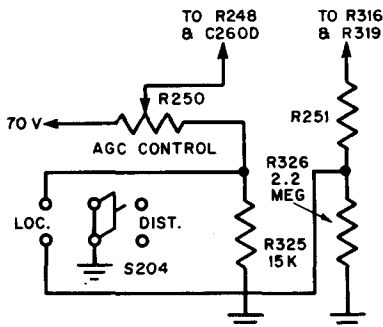

Fig. 48 — DuMont

To give increased sensitivity in weak-signal areas, a *Local-Distance* switch may be installed. The switch is used in *Local* position in locations having normally acceptable signal strength. It may be set in *Distance* position for increased sensitivity in weak-signal areas, provided the signal strength on other stations is not excessive. Evidence of such overloading might appear either as a loss in the full range of gray tones or as the presence of sound bars in the picture. In the *Distance* position, the receiver safely handles all signals below a 15,000-microvolt level.

To install the switch, proceed as follows:

1. Delete *F201*, fuse and fuse holder, and connect a-c line directly.

2. In the hole occupied by fuse holder install a DPDT toggle switch, *S204*, with end terminals facing side of chassis.

3. Disconnect *R250* (25k) from ground, and connect new resistor *R325* (15k) in series with *R250*. Connect other end of *R325* to ground.

4. Disconnect ground side of *R251* (270k), and connect new resistor *R326* (2.2 meg) in series with *R251*. Connect other ends of *R326* to ground.

5. Run two leads to switch and connect to terminals as shown in sketch; one from junction of *R251* and *R326*, another from junction of *R250* and *R325*.

6. Connect the two center terminals of *S204* with jumper and run to nearest ground.

## DUMONT Model RA-111A

### Reducing regeneration (see Fig. 49).

To reduce regeneration, a grounding spring (part No. 30015401) should be inserted between the *Inputuner* and the chassis as shown in the illustration.

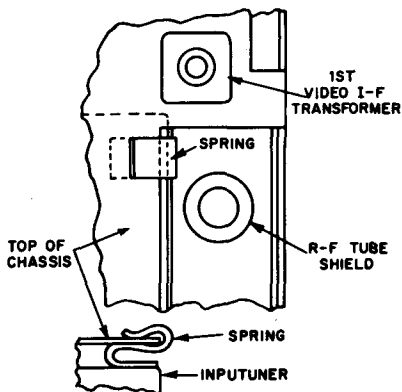

Fig. 49 — DuMont

**DUMONT Model RA-111A**  
**Packing at top of raster.**

To eliminate packing at the top of the raster, resistor *R296* (in plate circuit of the vertical saw generator) may be changed from 4,700 ohms to 5,100 ohms, 1/2 watt, 5%.

**DUMONT Model RA-111A**  
**Elimination of channel 7 beat**  
(see Fig. 50).

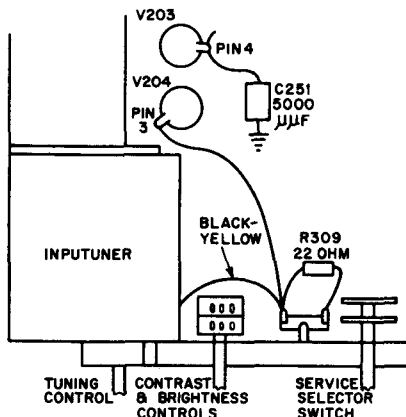

Fig. 50 — DuMont

A few complaints of an annoying beat on channel 7 in the RA-111A sets have been received. This interference is the result of the eighth harmonic (175.2 mc) of the sound i.f. (21.9 mc) beating against the video carrier (175.25 mc) of channel 7 and thus producing a 50-kc beat. This beat shows up in the picture as black horizontal streaks.

The following circuit changes are necessary to eliminate this condition:

1. Remove the heater connection between *V203* (6T8, first sound amplifier) and *V204* (6AQ5, second sound amplifier).

2. Reconnect the heater of *V204* (6AQ5, second sound amplifier) to heater tie-point of the *Inputuner*. This is located near the front end of the chassis between the band switch and the contrast control (see figure).

3. Connect a 5,000- $\mu\mu\text{f}$  capacitor between pin 4 (heater) of *V203* (6T8, first sound amplifier) and ground. The part added is *C251* and its part No. is 03015610.

**DUMONT Models RA-112 series, RA-113 series, RA-117 series**

**Beat pattern on channel 8.**

In some sets using a channel 5 trap, fine, diagonal lines, which may be varied as the fine tuning is rotated, occur on channel 8. The probable cause follows: The seventh harmonic (183.75 mc) of the video i.f. (26.25 mc) combines with the video carrier of channel 8 (181.25 mc) to produce a 2.5-mc beat. The following change will remedy this condition:

Connect a 2.5- $\mu\mu\text{f}$  capacitor between the plate of the video detector (pin 7 of *V209A*, 1/2 of 6AL5) to ground across the combination of *L219* (the 78.75-mc trap) and *C227* (5  $\mu\mu\text{f}$ ).

**DUMONT Models RA-112 series, RA-113 series**  
**Preventing breakdown of R262.**

The 100,000-ohm resistor (*R262*) connected to the horizontal-hold control should be increased from a 1/2-watt unit to a 1-watt unit to prevent recurrent breakdown due to overheating.

Note: Later production chassis incorporate this change.

**DUMONT** Models RA-112 series, RA-113 series

**Reduction of a-m radio interference.**

Several cases of a-m radio interference caused by sweep radiation have been reported. Bypassing each side of the a-c line at the set with .02- $\mu$ f, 600-volt capacitors will reduce this interference. The capacitor leads should be kept as short as possible. The part number of these capacitors is 03018570. This change is incorporated in RA-112A sets beginning with serial No. 1211601 and RA-113 sets beginning with serial No. 1313901.

**DUMONT** Models RA-112 series, RA-113 series

**Improvement of sound sensitivity.**

In any location where it is found that the sound output is insufficient, it may be substantially increased by making the following simple modification: Connect a 10- $\mu$ f (or larger), 25-volt capacitor in parallel with *R126*, the cathode resistor of the 6AQ5 sound-output stage. The part number for the capacitor is 03016730. This capacitor is being installed in current production.

**DUMONT** Models RA-112 series, RA-113 series

**Defective video i-f transformers**  
(see Fig. 51).

Some complaints of breakdown of the ceramic coupling capacitor in the video i-f transformers have been received. The condition encountered

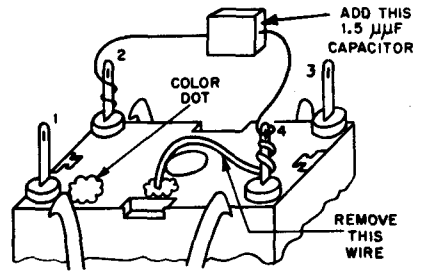

Fig. 51 — DuMont

was an arc-over between the end of the silvered ceramic tube and the bare wire that fits into it. The condition was later corrected by the use of a synthetic-coated wire.

It is not necessary to replace the entire transformer to correct this defect. Instead, the bare wire should be removed from the ceramic tube and a 1.5 $\mu$ f, 400-volt type GA-3 *Stack-pole* capacitor, or equivalent, should be connected between terminals 2 and 4 (grid to plate) of the transformer. After making this change, a slight amount of rephasing of the grid and plate coils of the respective transformers will usually be necessary.

**DUMONT** Models RA-112 series, RA-113 series

**Interference on channel 7.**

To alleviate interference on channel 7, capacitor *C230* (.005  $\mu$ f) is added from pin 4 of *V203* (sound discriminator) to ground. Later production runs included this change.

**DUMONT** Models RA-112 series, RA-113 series

**Reducing tuneable hum.**

To reduce tuneable hum, change the value of capacitor *C237*, con-

nected between pin 7 of the sync detector (*V213*) and ground, from 150  $\mu\text{f}$  to .05  $\mu\text{f}$  at 200 volts. The part number of the new component is 03000950.

**DUMONT** Models RA-112  
series, RA-113 series

**Preventing regeneration and  
increasing accompanying  
sound attenuation.**

The following changes are made to relieve regeneration, and to increase accompanying sound attenuation.

1. Add a 10,000-ohm,  $\frac{1}{2}$ -watt resistor (*R305*) across *L202* (video detector peaking coil).

2. Add resistor *R272*, 68,000 ohms, across *Z208-1* and *Z208-2* (last video i-f transformer).

3. Change a .005- $\mu\text{f}$  capacitor *C230* from present location, pin 4 of *V203* to ground, and connect it from ground to pin 4 of *V207*.

4. Change *L213* in first video i.f. from part No. 21005902 to part No. 210066781. This coil has lower inductance range, obtained by using fewer turns.

5. Redress and shorten lead from junction of *R237*, *C276* (cathode circuit of video amplifier, *V210*) to contrast control *R239A*. Keep this lead away from the *Inputuner*.

6. Capacitor *C290*, (.005  $\mu\text{f}$ ) is connected at junction of *R246* (screen-grid circuit of *V212*) and S135-volt line to ground.

7. Change *C238* (in agc line) from .001- $\mu\text{f}$  paper to .001- $\mu\text{f}$  ceramic or mica, part No. 03015810 or part No.

03020730, and move to agc lead closest to narrow band sync shield.

8. Add *L205*, part No. 21004465, between the video detector and video detector peaking coil.

9. Add tube shield on 6BC5 fourth video i-f amplifier tube.

10. *L201* (part of video-detector load) is to be changed from part No. 21006629 to part No. 21006627.

**DUMONT** Model RA-113  
series

**Picture-tube substitution.**

When it becomes necessary to replace the picture tube, the 17BP4A may be directly substituted in this chassis for the 17AP4 used in production. Since the 17BPA is slightly longer than the 17AP4, the back cover may interfere with the socket wiring. This condition may be remedied by repositioning one or two of the cover screws to permit the cover to bulge outward slightly.

**DUMONT** Model RA-116A  
**No picture with normal raster.**

Although there is no picture, the raster is normal. A check in the video i-f strip reveals that the 3,300-ohm resistor (*R239*), in the plate circuit of the first video i-f stage (pin 5 of *V208*, 6AU6), is burned up. The 39-ohm resistor (*R241*) connected to the cathode of the second video i-f stage (pin 7 of *V209*, 6AU6) is also burned.

Probable cause is a shorted coupling capacitor in the first video i-f transformer (*Z206*). This drives the grid of *V209* heavily positive, drawing current from +B through *R239*,

which is overloaded. The heavy conduction of *V209*, as a result of its positive grid, overloads its cathode resistor, *R241*.

It is not sufficient to replace *R239* and *R241*, as they will burn out again. The transformer, *Z206*, must also be replaced. It is also important to check *V209* carefully, as excessive conduction may have damaged this tube.

**DUMONT** Model RA-117 series

**Sync stability improvement.**

The effectiveness of the narrow-band sync stage may be improved by replacing the narrow-band sync transformer with a newly designed one which gives greater gain. Proceed as follows:

1. Replace the narrow-band sync transformer (*Z209*) with the new type (*Z210*, part No. 20006231).

2. Replace resistor *R249* (18,000 ohms), which is connected to pin 5 of *V213* (sync and agc detector, 6AL5), with 27,000 ohms, 1/2 watt, 10% (part No. 02031940).

3. Replace capacitor *C236* (33  $\mu\mu\text{f}$ ), which is also connected to pin 5 of *V213*, with 20  $\mu\mu\text{f}$ , 500 volts, 10%, ceramic (part No. 03015790).

**DUMONT** Model RA-117 series

**Motorboating in audio.**

In some chassis, inductive feedback from the audio amplifiers to the tuner through pick-up in the red +B lead will cause a sound recognized as motorboating. This may be

corrected as follows: Change capacitor *C303*, located between the tie point of the red +B tuner lead and ground, from .1- $\mu\text{f}$  paper to 10- $\mu\text{f}$  electrolytic, 450 volts (part No. 03019410).

**DUMONT** Model RA-117 series

**Neck shadow reduction.**

Difficulty in adjusting the focus coil to reduce neck shadow may be caused by incorrect polarity of this component. In this case, reversal of the focus coil leads will make adjustment easier.

**DUMONT** Model RA-117 series

**Improving video i-f bandpass.**

If normal alignment procedure does not produce an acceptable video i-f response characteristic, the curve may be flattened as follows: Change resistor *R332* (5.6k), located at the grid of the first video i-f stage (pin 1 of *V205*, 6BA6), to 2.7k, 1/2 watt, 5% (part No. 02030580).

Note: Chassis with serial No. 173000 and higher incorporate this change.

**DUMONT** Model RA-117 series

**Intermittent flashing in picture.**

If intermittent flashes and white streaks occur in the picture, usually decreasing in intensity as the set warms up, the probable fault is an intermittent short in a tube in the tuner. Replace the defective tube.

**DUMONT**

**Model RA-117  
series**

**Vertical drift correction.**

Vertical drift may be caused by a change in the value of the capacitor *C271* (.01  $\mu\text{f}$ , 400 volts) connected to the primary of *T203* (vertical blocking oscillator transformer). If this occurs, change *C271* to a 600-volt component (.01  $\mu\text{f}$ , 600 volts, 5%, paper, part No. 03101540) to decrease the possibility of changing value.

**DUMONT**

**Model RA-117  
series**

**Sound bars in picture.**

If audio appears in the picture when the volume control is turned up, the probable cause is an open 10- $\mu\text{f}$  section of 4-section electrolytic capacitor *C260* (30  $\mu\text{f}$ , 10  $\mu\text{f}$ , 10  $\mu\text{f}$ , 10  $\mu\text{f}$ ). Replace the complete capacitor or the faulty section.

**DUMONT**

**Model RA-117  
series**

**Adaptation for 300-ohm input.**

In relatively noise-free fringe locations, a low-loss 300-ohm line will often produce better results than 72-ohm coax, for which the receiver's input is matched. To adapt the set for 300-ohm line, proceed as follows:

1. Unsolder all leads connecting the *Inputuner* to the main chassis, and remove the *Inputuner*.
2. Remove the tuner bottom cover.
3. Unsolder the center conductor of the coax cable from the lead to which it is connected at one end of

the antenna input transformer (lead No. 2).

4. Unsolder the shield of the coax cable from the tuner and remove the cable.

5. Cut a length of 300-ohm line approximately one inch longer than the coax which has just been removed, and strip its ends.

6. Insert one end through the opening through which the coax was fed.

7. Connect one end of the line to lead No. 2, to which the center conductor of the coax cable was formerly connected.

8. Connect the other end to lead No. 4, which is at the other end of the antenna input transformer.

**DUMONT**

**Model RA-117  
series**

**Reduction of phonograph buzz.**

Buzz in the audio circuit when these receivers are used in the phonograph position may be reduced by the following change: Connect a jumper between pin 3 of the *Phono-TV Switch* (S-201) and the -50v point at the junction of *R292* (vertical-hold control) and *R299* (vertical-linearity control).

**DUMONT**

**Model RA-117  
series**

**Horizontal pulling.**

Horizontal pull may be caused by excessive modulation of the transmitted signal, permitting some video signal to enter the sync circuits and to disturb the operation of the hori-

zontal oscillator. To correct this condition, proceed as follows:

1. Remove the junction of capacitor *C261* (.1  $\mu\text{f}$ ) and resistor *R249* (18k) from pin 5 of *V213* (sync and agc detector, 6AL5). Capacitor *C236* (33  $\mu\text{f}$ ) remains at pin 5.

2. Insert new resistor *R340* (1 meg,  $\frac{1}{2}$  watt, 20%, part No. 02032600) between this junction and pin 5.

3. Insert new capacitor *C310* (.1  $\mu\text{f}$ , 200 volt, 20%, paper, part No. 03014780) in the circuit across *R340*.

4. Change capacitor *C287* (.05  $\mu\text{f}$ ), in the cathode circuit of the sync amplifier (pin 7 of *V212*, 6BA6), to .005  $\mu\text{f}$ , (ceramic, part No. 03015610).

**DUMONT**                      **Model RA-117**  
   **series**

**Beat pattern on channel 5.**

If a beat pattern (fine, diagonal lines) occurs on channel 5, perform step 1. If the pattern is still conspicuous, the effectiveness of the beat-interference trap may be increased by rerouting the wiring arrangement as noted in the remaining steps:

1. Carefully tune the 78.75-mc trap (*L219*), connected to the plate of the video detector (pin 7 of *V209*, 6AL5), until the beat pattern disappears or is at a minimum.

2. Remove capacitor *C227* (5  $\mu\text{f}$ ) from the bottom of *L219* and from its present ground connection (pin 6 of *V-209*).

3. From the top of *L219*, disconnect the jumper going to pin 7 of *V209*.

4. Reconnect this jumper to the bottom of *L219* (to which *C227* was formerly attached).

5. Connect one end of *C227* to the top of *L219* (to which the jumper was formerly attached).

6. Connect the other end of *C227* to the ground point at the tab to which *C220* and *L212* are connected.

Note: Chassis with serial No. 1723000 and higher incorporate this change.

**DUMONT**                      **Model RA-117**  
   **series**

**Streak pattern on channel 7.**

A pattern of streaks which occurs on channel 7 may be caused by the eighth harmonic of the sound carrier ( $21.75 \text{ mc} \times 8 = 174 \text{ mc}$ ), which is produced in the audio discriminator (*V203*). It feeds into the video i-f strip through the agc clamp (also located in the envelope of *V203*) and beats with the video carrier to produce the effect. To correct, proceed as follows:

1. Add new capacitor *C208* (5,000  $\mu\text{f}$ , ceramic, part No. 03015610) from pin 4 of *V203* (6T8) to ground.

2. Insert new coil choke *L207* from pin 6 of *V203* to the junction of resistors *R265* (10 meg) and *R318* (1 meg). This junction is located near *V212*.

Note: Chassis with serial No. 173081 and higher incorporate this change.

**DUMONT**                      **Model RA-119A**  
**High-voltage instability.**

Change the plate-load resistor (*R325*) of the control reference tube

(V308, VR75/0A3) in the high-voltage section from 110,000 ohms to 25,000 ohms, 10 watts, 5% (part No. 02108110). This change will improve the high-voltage stability.

**DUMONT** Model RA-119A  
**Vertical bars in picture.**

The presence of two dark, fairly wide, vertical bars in the picture indicates that some of the 31.5kc high-voltage oscillator signal is present in the video circuits. To eliminate, proceed as follows:

1. Obtain a .01- $\mu$ f, 600-volt paper capacitor (part No. 03012560).

2. Connect one end of the new capacitor to the junction between the horizontal sweep protective relay (K302) in the high-voltage chassis and the +338v line.

3. Connect the other end to chassis ground.

Note: Chassis with serial No. 19118 and higher incorporate this change. On new schematics, the new capacitor is marked C330.

**DUMONT** Model RA-119A  
**High-voltage failure.**

Improper distribution of voltage across the resistors in the high-voltage bleeder circuit may cause repeated voltage failures. To prevent recurrence, change the resistors to the values noted below. All the resistors involved are located between the filament-cathode of one high-voltage rectifier and the plate of the other (pin 7 of V306, 1B3, and the plate cap of V307, 1B3).

1. Change R333 from 470 k to 820 k, 2 w, 10%, part No. 02038120.

2. Change R334 from 470 k to 560 k, 2 w, 10%, part No. 02038100.

3. Change R336 from 470 k to 330 k, 2 w, 10%, part No. 02038070.

4. Change R337 from 470 k to 180 k, 2 w, 10%, part No. 02038040.

5. Change R338 from 470 k to 100 k, 2 w, 10%, part No. 02038010.

Note: Chassis with serial No. 19118 and higher incorporate this change.

**DUMONT** All metal picture-tube models

**Distorted raster.**

On models using cathode-ray tubes with metal cones, the picture and the raster line may be distorted. This type of distortion will generally appear to be most severe at one particular portion of the raster. It is due to magnetization of the metal cone and may be remedied by the following steps:

1. Locate the magnetized area of the cone with a compass.

2. Demagnetize the cone by passing it through a strong, alternating magnetic field. Such a field may be obtained by removing the case from a focus coil and by passing a.c., obtained from a *Variac* or other suitable source, through the coil. The flat side of the coil should be passed over the magnetized area of the cone. The a.c. should not be interrupted while the coil is near the tube.

**DUMONT** All models  
**Deflection yoke stuck.**

It is sometimes necessary to remove a deflection yoke which has be-



come stuck to the neck of the picture tube in the television receiver. Such a deflection yoke may be removed by applying approximately 50 volts, a.c., from a *Variac*, to the horizontal winding of the yoke. This procedure will heat and soften the polyethelene sleeve, thereby freeing the yoke from the neck of the tube.

## DUMONT

All models

### ***Flashing on screen.***

The cover on the yoke connector is probably contacting the focus-coil case intermittently. While both are grounded, there is enough potential difference between them to cause the above difficulty. Remedy the trouble by redressing the yoke cable.



# INDEX

# INDEX

	Page
300-ohm input, addition of, <i>DuMont</i> , RA-117 series.....	99
4.5-mc interference, <i>see</i> interference due to 4.5 mc	
4.5-mc trap, alignment of, <i>Admiral</i> , 24D1 through 24H1.....	16-17
60-cycle ripple, <i>see</i> Vertical roll	

## A

Adjacent channel interference, <i>see</i> Interference, due to adjacent sound channel	
<i>Admiral</i> .....	1-23
AFC, horizontal circuit modification, <i>see</i> Picture bending at top operation, improving, <i>Belmont-Raytheon</i> , 20AY21.....	44
AGC, change for high-noise areas, <i>Admiral</i> , 20T1, 20V1, 21B1 through 21E1, 21H1, 21J1 .....	6
circuit, addition of, <i>Andrea</i> , VL-16 .....	27-28
cross-over value, <i>Capehart-Farnsworth</i> , CX-33 .....	55-56
external adjustment, <i>Crosley</i> , models with external agc adjustment .....	75
improved operation, <i>Capehart-Farnsworth</i> , CX-33DX .....	65
<i>see also</i> Horizontal tearing	
preventing overloading, <i>Admiral</i> , 20T1, 20V1 .....	7
<i>Capehart-Farnsworth</i> , CX-33DX .....	64
<i>Crosley</i> , 321-4, 331-4 .....	75
stability, improving, <i>Air King</i> , 700-10, -20, -30, -40, -50....	25
voltage reduction, <i>see</i> Sensitivity, increased by reduc- tion of agc voltage	
voltage removing, <i>see</i> Snow	

	Page
<i>Air King</i> .....	24-26
Alignment, unsealing slug, <i>Admiral</i> , 3JA1 .....	23
<i>see</i> Video i-f bandpass, improving	
A-M radio interference, <i>see</i> Interference, due to A-M radio	
<i>Andrea</i> .....	27-28
Antenna-transformer, connections, <i>Andrea</i> , VL-12, -16, -19 .....	27
Aquadag, white coating on, <i>CBS-Columbia</i> , all chassis .....	67
Arcing, <i>Admiral</i> , 24D1 through 24H1 .....	19-21
<i>Andrea</i> , VL-16 .....	28
at 6S4, to chassis, <i>Admiral</i> , 24D1 through 24H1 .....	18
at high-voltage anode suction cup, <i>CBS-Columbia</i> , all chassis .....	67-68
at high-voltage assembly, <i>Crosley</i> , 10-414MU, 10-416M1U .....	74
at high-voltage capacitor, <i>Capehart-Farnsworth</i> , CX-33 .....	56-57
at high-voltage supply, <i>Capehart-Farnsworth</i> , CX-33 .....	53
on picture tube, <i>Crosely</i> , metal-picture tube models....	76
on second-anode lead, <i>Admiral</i> , 21B1, 21C1 .....	13
on second-anode terminal, <i>Crosley</i> , glass picture tube models .....	75-76
<i>see also</i> , Lead, breakdown between, preventing	
<i>Arvin</i> .....	29-38
Audio buzz (or hum), reduction, <i>Admiral</i> , 21B1 through 21D1 .....	12
<i>Air King</i> , 700-series .....	24
700-93 .....	26

	Page		Page
from vertical oscillator, <i>Admiral</i> , 24D1 through 24G1 .....	21	<i>see also</i> Audio buzz overmodulation, <i>see</i> Sensitivity, sound phonograph, <i>DuMont</i> , RA-117 series .....	99
in speaker at minimum volume, <i>Arvin</i> , TE-272-1, TE-272-2, TE-276....	29	sync, due to transmitter overmodulation, <i>Capehart-Farnsworth</i> , CX-33 .....	60
on strong signals, <i>Arvin</i> , TE-272-1, TE-272-2, TE-276....	30	<i>see also</i> Hum and Sync buzz vertical sync, <i>Capehart-Farnsworth</i> , CX-33 .....	48, 53
<i>see also</i> Buzz, and Intercarrier buzz			
Audio hash, <i>see</i> Sound, whistle in, reducing			
Audio motorboating, <i>DuMont</i> , RA-117 series .....	98		
Audio output, increasing, <i>Admiral</i> , 30A1 through 30D1 .....	22-23		
Audio sensitivity, increasing, <i>Air King</i> , 700-10, -20, -30, -40, -50....	25		
<b>B</b>			
Barkhausen oscillations, <i>DuMont</i> , RA-104A, RA-110A .....	83-84		
Beat pattern, on channel 5, <i>DuMont</i> , RA-117 series .....	100		
on channel 7, <i>DuMont</i> , RA-103D, RA-104A .....	82-83		
RA-109A .....	90-91		
RA-110A .....	82-83		
RA-111A .....	95		
on channel 8, <i>DuMont</i> , RA-112, RA-113, RA-117 series .....	95		
<i>Belmont-Raytheon</i> .....	38-45		
<i>Bendix</i> .....	45-46		
Blanking of vertical— retrace lines, <i>see</i> Vertical-retrace lines, blanking of			
Blocking, on strong signals, <i>Capehart-Farnsworth</i> , CX-33 .....	58		
Blooming, <i>see</i> Picture blooming, reducing			
Bounce, <i>see</i> Vertical jitter, correcting			
Brightness-control, <i>see</i> picture brightness			
Brilliance, improving, <i>Capehart-Farnsworth</i> , CX-33 .....	51		
inability to reduce, <i>Capehart-Farnsworth</i> , CX-30 .....	49		
Burning, <i>see</i> Arcing			
Buzz, carrier, <i>Crosley</i> , 1950 models .....	70		
1951 models .....	71		
intercarrier, <i>see</i> intercarrier buzz			
		<b>C</b>	
		Cabinet repair, of broken hinge, <i>Crosley</i> , 1951 models .....	70-71
		of scratches on plastic, <i>Admiral</i> , 20T1, 20V1, 24D1 through 24H1 .....	7
		Calbest .....	46
		Capacitor breakdown, <i>DuMont</i> , RA-103D, RA-104A, RA-110A .....	82
		of C142, <i>Belmont-Raytheon</i> , 20AY21 .....	45
		of C214, <i>Admiral</i> , 24D1 through 24G1 .....	21
		shorted coupling, <i>see</i> Picture blank, raster normal	
		Capacitor substitution, of C278, <i>Capehart-Farnsworth</i> , CX-33 .....	56
		parts replacement, <i>DuMont</i> , RA-103D, RA-104A, RA-110A .....	82
		<i>Capehart-Farnsworth</i> .....	47-65
		Carrier buzz, <i>see</i> Buzz, carrier	
		CBS-Columbia .....	66-68
		Centering, improved raster, <i>see</i> Focus coil adjustment	
		Certified .....	68-69
		Channel 5 beat pattern, <i>see</i> Beat pattern on channel 5	
		Channel 7 beat pattern, <i>see</i> Beat pattern on channel 7 <i>see also</i> Interference, on channel 7	
		Channel 8 beat pattern, <i>see</i> Beat pattern on channel 8	
		Channel-switch shaft, slippage, <i>Arvin</i> , TE-290 .....	33
		Cleaning aquadag surface, <i>see</i> Aquadag	
		Contrast control, improving operation, <i>Crosley</i> , 1949 models, LD series....	69-70
		increasing range of, <i>Air King</i> , all 16-inch chassis .....	26

	Page
Controls, <i>see</i> Horizontal-hold control, Vertical-centering control, etc.	
Corona, <i>see</i> Arcing	
Crosley .....	69-78
Crystal detector, checking and replacing, <i>Belmont-Raytheon, 17AY27</i> .....	43-44

## D

Deflection, increasing in tuning indicator, <i>DuMont, RA-109A</i> .....	92
Deflection yoke, <i>see</i> Yoke, <i>see also</i> Picture height excessive	
Dial calibration, <i>Andrea, VL series</i> .....	27
Distortion, <i>see</i> High-frequency distortion	
Double pulsing, <i>CBS-Columbia,</i> 700 series chassis .....	67
Drift, <i>see</i> Horizontal-oscillator drift, <i>see also</i> Vertical drift	
DuMont .....	78-102

## F

Feedback, inductive, <i>see</i> Audio motorboating	
Flag-waving, <i>see</i> Picture bending at top	
Flicker, <i>see</i> Picture flicker	
Flyback transformer, <i>see</i> Transformer, flyback	
Focus adjustment, making less critical, <i>Capehart-Farnsworth, CX-33</i> .....	60
Focus coil, adjustment, <i>Bendix, 2025, 3033, 6002</i> .....	45
reversed, neck shadow due to, <i>Crosley, 10-401, 10-404, 10-412,</i> 10-414, 10-416, 10-418 .....	72
<i>DuMont, RA-117 series</i> .....	98
Focus control, centering and adjustment, <i>Certified, 49-10</i> .....	68
improving operation, <i>Admiral, 24D1</i> through 24G1 .....	21
increasing range of, <i>Arvin, 12½-inch chassis</i> .....	37
<i>Capehart-Farnsworth, CX-30</i> .....	49

	Page
<i>CBS-Columbia, 700 series</i> .....	67
<i>Crosley, 1952 models with 20- and</i> 21-inch picture tubes .....	71-72
Fringe-area operation, modifications for improved performance, <i>Capehart-Farnsworth,</i> <i>CX-33</i> .....	61, 62-63
<i>see also</i> Sensitivity, increasing for fringe area operation	
Fuse, replacement, <i>Crosley, 1951 models</i> .....	71
<i>DuMont, RA-111A</i> .....	94
rewiring of, <i>DuMont, RA-109A</i> .....	92

## G

Gain, *see* Sound, quieting  
and gain, increasing

## H

High-channel sensitivity, increasing, <i>DuMont, RA-109A, RA-111A</i> .....	89-90
High-frequency, distortion, <i>DuMont, RA-109A</i> .....	92
tone quality improvement, <i>DuMont, RA-109A</i> .....	90
High-noise level, <i>see</i> AGC, circuit change for high-noise areas	
High-voltage arcing, <i>see</i> Arcing at high voltage	
High-voltage breakdown, <i>DuMont, RA-119A</i> .....	101
between yoke windings, <i>Capehart-Farnsworth,</i> <i>CX-33DX</i> .....	65-66
High-voltage instability, <i>DuMont, RA-119A</i> .....	100-101
insufficient, <i>DuMont, RA-103D, RA-104A,</i> <i>RA-108A, RA-110A</i> .....	81
lead dress, <i>see</i> Lead dress in high- voltage compartment, <i>see also</i> Lead dress, high-voltage supply	
Hinge, repair, <i>see</i> Cabinet, repair of broken hinge	
Horizontal bars, white, <i>see</i> Noise pulses, high amplitude, <i>see also</i> Vertical foldover	

Page	Page
Horizontal black streaks, see Beat pattern on channel 7	
Horizontal-drive control, prevention of squegging, <i>Belmont-Raytheon</i> , 16AY28, 17AY21 .....	43
Horizontal foldover, see Horizontal-hold control, foldover elimination of	
Horizontal-hold control, foldover, elimination of, <i>Air King</i> , 700-10 or later .....	24
700-90 through 700-96 .....	26
<i>Capehart-Farnsworth</i> , CX-30 .....	50
CX-31 .....	51
<i>Certified</i> , 49-10 .....	68
<i>DuMont</i> , RA-109 series .....	88-89
increasing range of, <i>Arvin</i> , TE-3J2-2, TE-315-1 .....	35
<i>Crosley</i> , 10-414MU, 10-416MU, 10-416MIU, 10-429MU .....	73
see also Horizontal linearity	
Horizontal hold unstable, see Horizontal-hold control, foldover, elimination of	
Horizontal instability, <i>CBS-Columbia</i> , 700 series .....	67
<i>DuMont</i> , RA-109 series .....	88-89
Horizontal linearity, affected by horizontal-hold control, <i>Admiral</i> , 24D1 through 24H1 .....	18
obtaining, <i>Belmont-Raytheon</i> , 16AY28, 16AY211, 17AY21, 17AY24 .....	42-43
improving, <i>Air King</i> , 700-10, .20, .30, .40, .50 .....	25-26
<i>Belmont-Raytheon</i> , 7DX22-P .....	38-39
<i>DuMont</i> , RA-111A .....	93
Horizontal multivibrator, stabilized, <i>Belmont-Raytheon</i> , 10DX21, 10DX22, 10DX24 and 10AXF43, series A (No-Code or Code B) ...	39-41
Horizontal-oscillator, drift, <i>Crosley</i> , 10-401, 10-404, 10-412, 10-414, 10-416, 10-418 .....	72-73
radiation, reduction of, <i>Admiral</i> , chassis with metal picture tubes .....	23
Horizontal-output, reducing parasitics in horizontal- output tube, <i>Admiral</i> , 24D1 through 24H1 .....	17
transformer, <i>DuMont</i> , RA-109 series .....	89
Horizontal picture jitter, see Picture jitter	
Horizontal picture shift, see Picture shift	
Horizontal pulling, <i>Belmont-Raytheon</i> , 20AY21 .....	44
<i>DuMont</i> , RA-117 series .....	99-100
Horizontal scan, increasing, <i>Belmont-Raytheon</i> , 20AY21 .....	44
<i>Capehart-Farnsworth</i> , CX-31 .....	50-51
CX-33 .....	52, 58-59
see also Sweep width, increasing	
intermittent, correcting, <i>Capehart-Farnsworth</i> , CX-33 .....	56
see also Width coil	
Horizontal-sweep, sing, <i>Crosley</i> , 10-401, 10-402, 10-412, 10-418 .....	73
Horizontal-sync instability, see Sync, stability, improving vertical	
Horizontal tearing (or bending), <i>Admiral</i> , 20T1, 20V1, 21B1 through 21E1, 21H1, 21J1 .....	4-5
<i>Capehart-Farnsworth</i> , CX-31 .....	50
<i>Certified</i> , 49-10 .....	69
Horizontal white bar at top of raster, see Sync, stability, improving vertical	
Horizontal-yoke lead radiation, see Interference, radio, from horizontal-sync radiation	
Hum, 120-cycle, <i>Capehart-Farnsworth</i> , CX-31 .....	51
in sound, <i>DuMont</i> , RA-109A .....	90
modulation, <i>Crosley</i> , model DU-UHFP (UHF converter) .....	78
pick up, <i>Admiral</i> , 24D1 through 24H1 .....	17
tuneable, <i>DuMont</i> , RA-112 series, RA-113 series .....	96-97
see also Buzz	
I	
I-F amplifiers, oscillation, <i>Bendix</i> , all chassis .....	45-46

	Page
I-F coils, see I-F amplifiers, oscillation	
I-F harmonic feedback, <i>Capehart-Farnsworth, CX-33DX</i> .....	64
I-F trap, see Interference due to harmonics of sound i-f	
Inductuner, see Tuner unit	
Inputuners, see Signal-handling ability, improving	
Intercarrier buzz, <i>Arvin, TE-289-3</i> .....	32-33
<i>TE-290</i> .....	33
due to improper transmitter modulation, <i>Admiral, 20X1</i> through 20Z1 .....	9-10
due to misalignment, <i>Admiral, 20X1</i> through 20Z1 .....	8-9
due to stray capacitance coupling, <i>Admiral, 20X1</i> through 20Z1 .....	9
see also Buzz; Audio buzz; Sync buzz	
Interference, due to 4.5 mc <i>Admiral, 21B1</i> .....	14-16
due to adjacent sound channel <i>Admiral, 20A1, 20B1, 21A1</i> .....	2
20Z1, 21B1, 21C1 .....	10
21B1, 21C1 .....	13-14
24D1 through 24H1 .....	18-19
<i>DuMont, RA-105, RA-106</i> .....	84-86
see also Sound Traps, installation, adjacent channel	
due to adjacent video channel, <i>Admiral, 24D1</i> through 24H1 .....	18-19
due to a-m radio, <i>DuMont, RA-112 series,</i> <i>RA-113 series</i> .....	96
due to harmonics of sound i.f., <i>Admiral, 20B1, 21A1</i> .....	2-3
<i>Arvin, TE-302-3, TE-315-2</i> .....	36
on channel 7, <i>DuMont, RA-112 series,</i> <i>RA-113 series</i> .....	96
<i>RA-117 series</i> .....	100
radio, from horizontal-sync radiation, <i>Capehart-Farnsworth, CX-30</i> .....	49
Interlace, improving, <i>Arvin, TE-272</i> .....	29
<i>Capehart-Farnsworth, CX-33</i> .....	54
<i>DuMont, RA-109A</i> .....	8
Intermittent operation, <i>Admiral, 20T1, 20V1, 21B1</i> through 21E1, 21H1, 21J1 .....	5

	Page
see Picture, intermittent flashing on	
Intermodulation buzz, in sync and audio tubes see Buzz, reduction intercarrier	

## J

Jitter, see Horizontal instability see also Vertical jitter	
---	--

## L

Lead dress, in high-voltage compartment, <i>Capehart-Farnsworth, CX-33</i> .....	57-58
in high-voltage supply, <i>Belmont-Raytheon,</i> <i>16AY28, 16AY211,</i> <i>17AY24, 17AY27,</i> <i>20AY21</i> .....	42
Leads, breakdown between, preventing, <i>Crosley, 10-401, 10-404MU,</i> <i>10-404MIU, 10-412MU,</i> <i>10-418MU, 10-420MU</i> .....	73
Line fuse insertion, <i>Andrea, VL-16</i> .....	28
Linearity, see Horizontal linearity, see also Vertical linearity	
Local-Distance switch, installation of, <i>DuMont, RA-111A</i> .....	94

## M

Microphonic condition, see Oscillator tube, microphonic	
Misalignment, see Intercarrier buzz due to misalignment, see Sound, distorted due to misalignment	
Moding, see Double pulsing	
Motorboating, see Audio motorboating	

## N

Neck shadow, reduction, see Focus coil, reversal	
---	--

	Page
Noise,	
high,	
<i>see</i> Sync noise immunity,	
<i>see also</i> Noise rejection, sound	
section, improvement	
improved immunity for horizontal	
sync,	
<i>see</i> Sync, noise, improved immunity	
to impulse-type noise,	
<i>Arvin, TE-286</i> .....	30-31
improved immunity to vertical	
triggering,	
<i>Air King, 700-10, -20, -30, -40, -50</i> ....	25
pulses, high amplitude,	
<i>Admiral, 21 series chassis</i> .....	11
rejection, sound section, improvement,	
<i>Arvin, TE-300, TE-315</i> .....	34-35
streaks,	
<i>see</i> Fringe-area operation,	
modifications for improved	
performance	

O

Oscillations,	
<i>see</i> Barkhausen oscillation from	
sound i.f.,	
<i>see also</i> Sound, regeneration in i-f	
amplifier	
Oscillator,	
drift, excessive,	
<i>Admiral, 30D1</i> .....	23
spill-over,	
<i>Certified, 49-10</i> .....	69
Oscillator tube,	
microphonic,	
<i>DuMont, RA-103D, RA-104A,</i>	
<i>RA-105B, RA-108A, RA-110A</i> ....	81
Overloading in strong-signal areas,	
<i>see</i> AGC, preventing overloading	

P

Packing,	
<i>see</i> Raster, packing at top of	
Parasitics,	
<i>see</i> Horizontal output, reducing	
parasitics in horizontal-output tube	
Phonograph buzz,	
<i>see</i> Buzz, reducing phonograph	
Picture and sound separation,	
<i>see</i> Separation of picture and sound	
Picture bending at top,	
<i>Capehart-Farnsworth, CX-33DX</i> .....	64

	Page
Picture blank, raster normal,	
<i>DuMont, RA-116A</i> .....	97-98
Picture blooming,	
<i>Capehart-Farnsworth, CX-33</i> .....	58
Picture brightness,	
<i>Admiral, 24D1</i>	
through 24H1 .....	17
<i>Belmont-Raytheon, 20AY21</i> .....	44
Picture centering,	
horizontally,	
<i>Capehart-Farnsworth, CX-30</i> .....	49-50
Picture cut-off, preventing,	
<i>Admiral, 21B1, 21F1</i> .....	14
Picture detail, improving,	
<i>Capehart-Farnsworth, CX-30</i> .....	48
Picture drift,	
<i>Belmont-Raytheon,</i>	
10DX21, 10DX22,	
10DX24 and 10AXF43,	
Series A (Code C or D),	
Series B (No-Code and	
Code 51) .....	41
Picture flicker,	
<i>DuMont, RA-103, RA-103C</i> .....	79
<i>DuMont, RA-105, RA-106</i> .....	84
Picture focus, improving,	
<i>Capehart-Farnsworth, CX-33</i> .....	55
Picture fuzziness,	
<i>see</i> Sync stability, improving	
Picture height,	
excessive,	
<i>Admiral, 20T1, 20V1</i> .....	7-8
<i>Capehart-Farnsworth, CX-33</i> .....	61
increasing,	
<i>Admiral, 21D1</i> .....	16
Picture intermittent,	
flashing on and off,	
<i>DuMont, RA-117 series</i> .....	98
<i>see also</i> Intermittent operation	
Picture jitter,	
horizontal,	
<i>Admiral, 20T1, 20V1</i> .....	7
24D1 .....	21
<i>see also</i> Picture drift; Picture shift	
vertical,	
<i>Admiral, 21B1</i>	
through 21E1, 21H1, 21J1 .....	11
Picture lines,	
<i>Capehart-Farnsworth, CX-33</i> .....	54-55
<i>see also</i> Sound, whistle in, reducing	
distorted,	
<i>DuMont, all metal picture-tube</i>	
models .....	101
Picture overloading,	
<i>CBS-Columbia, 700 series chassis</i> ....	67
Picture pulling at top,	
<i>Admiral, 30A1</i>	
through 30D1 .....	22
Picture ringing,	
<i>Capehart-Farnsworth, CX-33</i>	
with 19- or 20-inch picture tubes....	63



	Page
Picture ripple, <i>see</i> Hum, pick up	
Picture screen flashing, <i>DuMont</i> , all models ..... 102 <i>see also</i> Horizontal multivibrator, stabilized; Picture drift; Picture jitter	
Picture shift, intermittent horizontal, <i>Capehart-Farnsworth</i> , CX-33DX ..... 63 <i>see also</i> Picture drift	
Picture smear, removing, <i>Capehart-Farnsworth</i> , CX-30 ..... 48-49 <i>see also</i> Interference	
Picture, sound bars in, <i>DuMont</i> , RA-117 series ..... 99	
Picture tube, arcing, <i>see</i> Arcing, on picture tube grounding, <i>Crosley</i> , glass picture tube models.... 75 intermittent operation, <i>Andrea</i> , all chassis ..... 27 <i>see</i> Static charge, on chassis, preventing substitution, <i>DuMont</i> , RA-113 series ..... 97 substitution causing excessive brightness, <i>Admiral</i> , 20V1 ..... 8 window cleaning, <i>Admiral</i> , 20T1, 20V1, 24D1 through 24H1 ..... 7	
Picture-tube base, replacement of, <i>Crosley</i> , all models ..... 77	
Picture, vertical bars in, <i>DuMont</i> , RA-119A ..... 101	
Picture width, increasing, <i>Admiral</i> , 21D1, 21J1 ..... 16 <i>Crosley</i> , 321, 321-1, 321-2, 331, 331-1, 331-2 ..... 74 <i>see also</i> Width coil	
Polarity reversed, <i>see</i> Focus coil reversed, neck shadow due to	
Power-line voltage fluctuation, <i>see</i> Picture flicker	
Pulling, <i>see</i> Horizontal pulling	

## Q

Quieting, <i>see</i> Sound, quieting and gain, increasing	
---	--

## R

Raster, distorted, <i>see</i> Picture distorted focusing, <i>see</i> Focus control, increase range of packing at top of, <i>Dumont</i> , RA-111A ..... 95 ringing, <i>Arvin</i> , TE-290 ..... 33	
Raytheon, <i>see</i> <i>Belmont-Raytheon</i>	
Rectifier-tube, filament unlit, <i>DuMont</i> , RA-105B, RA-108A ..... 86	
Regeneration, in sound i-f amplifier, <i>see</i> Sound, regeneration in sound i-f amplifier in video, i.f., <i>DuMont</i> , RA-111 series ..... 93 reducing, <i>DuMont</i> , RA-111 ..... 94 RA-112, RA-113 ..... 97	
Resistor, failure of decoupling resistors, reduction of, <i>Air King</i> , 700-10, -20, -30, -40, -50... 25 preventing breakdown of R262, <i>DuMont</i> , RA-112 series, RA-113 series ..... 95-96 of R238, <i>DuMont</i> , RA-109 series ..... 89 replacement of R258, <i>Capehart-Farnsworth</i> , CX-33 ..... 53	
Retrace lines, removing, <i>Admiral</i> , 20A1, 20B1, 20T1, 20V1, 20X1 through 20Z1, 21A1, 21B1, 24D1 through 24H1, 30A1 through 30D1 ..... 1	
R-F tuner, <i>see</i> Tuner unit	
Rumble, background, preventing, <i>DuMont</i> , RA-109A ..... 91	

## S

Second-anode terminal arcing, <i>see</i> Arcing on second anode terminal	
Sensitivity, increasing, <i>Crosley</i> , DU-UHFP (UHF converter) ..... 77-78 <i>DuMont</i> , RA-109 series, RA-111 series ..... 88 increasing by reduction of agc voltage, <i>Admiral</i> , 20T1, 20V1 ..... 8 21B1 through 21E1, 21H1, 21J1 ..... 12	

	Page
increasing for fringe-area operation, <i>Admiral</i> , 20T1, 20V1, 21B1 through 21E1, 21H1, 21J1 .....	3-4
increasing on channel 7, <i>Arvin</i> , TE-289-3, T-290 .....	32
sound, increasing, <i>Arvin</i> , TE-289-3, TE-290-2, TE-290-3 .....	31-32
tuner, increasing, <i>Admiral</i> , 21B1 through 21E1, 21H1, 21J1 .....	12
Separation of picture and sound, <i>Crosley</i> , 10-401, 10-404, 10-412, 10-414, 10-416, 10-418 .....	72
Series-parallel resonant trap, <i>see</i> Interference, due to adjacent sound channel	
Shock hazard, reducing between chassis and ground, <i>DuMont</i> , RA-103D, RA-104A, RA-110A .....	82
Short-circuit hazard, <i>Admiral</i> , 24D1 through 24H1 .....	18
Signal, exceptionally strong, <i>see</i> Contrast-control, improving operation	
Signal handling ability, improving, <i>DuMont</i> , RA-103, RA-105 .....	81
Signal-to-noise ratio, <i>see</i> Sensitivity, increasing	
Slippage of channel-switch shaft, <i>see</i> Channel-switch shaft, slippage	
Smear, <i>see</i> Picture smear, removing	
Snaking, <i>see</i> Horizontal tearing	
Snow, <i>Arvin</i> , TE-289-2 .....	31
TE-290 .....	34
<i>DuMont</i> , RA-109 series, RA-119A .....	88
due to agc action, <i>see</i> AGC action, cross-over value <i>see also</i> Fringe-area operation, modification for improved performance	
Sound, adjacent channel interference, <i>see</i> Interference, due to adjacent sound channel	
Sound amplifiers, interchange of 1st and 2nd, <i>DuMont</i> , RA-109A .....	92-93
Sound and picture separation, <i>see</i> Separation of picture and sound	
Sound attenuation, improving, <i>DuMont</i> , RA-109A .....	92
<i>see also</i> Regeneration, reducing	
Sound bars in picture, <i>see</i> Picture, sound bars in	

	Page
Sound distorted due to misalignment, <i>Admiral</i> , 20T1, 20V1, 21B1 through 21H1, 21J1 through 21L1, 21P1, 21Q1 .....	3
Sound, i-f harmonics of, <i>see</i> Interference due to harmonics of sound i-f	
Sound, intermittent, <i>see</i> Intermittent operation	
Sound modulation, <i>see</i> Sync, sound modulation, eliminating	
Sound output insufficient, <i>see</i> Sound sensitivity, improvement	
Sound, quieting and gain, increasing, <i>Arvin</i> , TE-302-2, TE-215-1 .....	35
<i>DuMont</i> , RA-103D, RA-104A, RA-110A .....	83
Sound regeneration in i-f amplifier, <i>Certified</i> , 49-10 .....	68
Sound sensitivity, improvement, <i>DuMont</i> , RA-112 series, RA-113 series .....	96
Sound, squeal elimination, <i>Arvin</i> , TE-302-2, TE-315-1 .....	35
TE-302-4, TE-315-3 .....	36
Sound strip, eliminating regeneration, <i>Arvin</i> , TE-272 .....	29
Sound take-off, transformer adjustment, aligning, <i>Capehart-Farnsworth</i> , CX-33 .....	55
Sound trap, adjacent channel, installation, <i>Capehart-Farnsworth</i> , CX-33 .....	52-53, 59-60
Sound, whistle in, reducing, <i>Arvin</i> , TE-300, TE-315 .....	35
<i>Capehart-Farnsworth</i> , CX-33 .....	54-55
Speaker, rushing sounds in, <i>see</i> Oscillator, spill-over	
Spill-over, <i>see</i> Oscillator, spill-over	
Split and inverted picture, <i>see</i> Vertical bars, black	
Squeal, <i>see</i> Sound, squeal elimination	
Squegging, <i>see</i> Horizontal drive control	
Static charge, on chassis, preventing, <i>Admiral</i> , 24D1 through 24H1 .....	17
on picture-tube window, <i>Admiral</i> , 24D1 through 24H1 .....	17
Streak pattern on channel 7, <i>see</i> Beat pattern on channel 7, <i>see also</i> Interference on channel 7	
Strong signal areas, <i>see</i> AGC, preventing overloading, <i>see also</i> Vertical jitter	

	Page
Sweep radiation, reducing, <i>Crosley</i> , all models .....	77
Sweep width, increasing, <i>Admiral</i> , 20V1 .....	8
<i>see also</i> Horizontal scan, increasing,	
Sync action, vertical, improved, <i>Belmont-Raytheon</i> , 20AY21 .....	44
Sync amplifier, modification, <i>see</i> AGC, preventing overloading, <i>see also</i> Horizontal tearing	
Sync buzz, due to incorrect capacitor, <i>Admiral</i> , 21B1 through 21E1, 21H1, 21J1 .....	11
due to stray capacitive coupling, <i>see</i> Intercarrier buzz, pick-up through shielded lead, <i>Admiral</i> , 21B1 through 21E1, 21H1, 21J1 .....	11
reduction of, <i>Admiral</i> , 20V1 .....	8
<i>see also</i> Buzz; Intercarrier buzz; Picture jitter, vertical	
Sync clipper, <i>see</i> Picture jitter, horizontal	
Sync clipping, improving, <i>Capehart-Farnsworth</i> , CX-33 .....	54
Sync, horizontal instability, improving, <i>Capehart-Farnsworth</i> , CX-30, A-2 and A-3 series .....	47
CX-31 .....	50
<i>see also</i> Horizontal-oscillator drift	
Sync, intermittent, <i>see</i> Intermittent operation	
Sync noise immunity, <i>DuMont</i> , RA-103, RA-103C .....	79-81
horizontal, <i>Admiral</i> , 21B1, 21C1 .....	13
Sync signal compression, <i>see</i> Vertical jitter, correcting,	
Sync sound modulation, eliminating, <i>Capehart-Farnsworth</i> , CX-33 .....	52
Sync stability, improving, <i>Admiral</i> , 21B1 through 21E1, 21H1, 21J1 .....	11
21B1, 21C1 .....	14
<i>Air King</i> , all 16-inch chassis .....	26
700-90 through 700-96 .....	26
<i>Capehart-Farnsworth</i> , CX-33DX .....	64-65
<i>Crosley</i> , 1951, 1952, and 1953 models .....	71
<i>DuMont</i> , RA-117 series .....	98
vertical,	

	Page
<i>Air King</i> , 700 series .....	24
700-90 .....	26
<i>Arvin</i> , TE-272-1, TE-272-2, TE-276 .....	30

## T

Tearing, <i>see</i> Horizontal tearing,	
Thumping, preventing, <i>DuMont</i> , RA-108A, RA-110A .....	87
Tone quality, <i>see</i> High-frequency, tone quality improvement	
Transformer flyback lead, and chassis breakdown, preventing, <i>DuMont</i> , RA-109A .....	91
Transformer, video i-f defective, <i>see</i> Video i-f transformer, defective	
Transmitter overmodulation, <i>see</i> Buzz, sync, due to transmitter overmodulation	
Trapazoiding effect, <i>see</i> Yoke, apparent failure	
Tube, failure of 6BG6, <i>Capehart-Farnsworth</i> , CX-33 .....	51-52
increasing life of 6AH6, <i>Capehart-Farnsworth</i> , CX-33 .....	61
increasing life of 6AV5GT, <i>Arvin</i> , TE-389 .....	36-37
replacement of 12H6 with 6H6, <i>Admiral</i> , 21B1 through 21D1, 21J1 .....	12
Tuner, contact replacement, <i>Belmont-Raytheon</i> , 14AX21 .....	41-42
sensitivity, increasing, <i>see</i> Sensitivity, tuner, increasing	
Tuner unit, cleaning, <i>Crosley</i> , all models .....	76-77
Tuning acting jerky, <i>DuMont</i> , RA-103D, RA-104A, RA-110A .....	81-82
Tuning indicator, <i>see</i> Deflection, increasing in tuning indicator	
Tuning range, improving, <i>see</i> Sound take-off transformer adjustment, aligning	
Tuning stiffness, elimination, <i>Belmont-Raytheon</i> , all chassis .....	45
Tweet, <i>see</i> Sound, whistle in, reducing <i>see also</i> I-F harmonid feedback	

	Page		Page
<b>U</b>			
Unlit filament rectifier tube, see Rectifier tube, filament unlit		<i>Capehart-Farnsworth</i> , CX-33 .....	61-62
Unstable picture, see Snow		<i>CBS-Columbia</i> , all chassis below 700-100 series .....	66
<b>V</b>		Vertical roll, <i>Admiral</i> , 21D1 .....	16
Vertical bars, <i>Admiral</i> , 20T1, 20V1, 21B1 through 21E1, 21H1, 21J1 .....	4	Vertical scan, increasing, <i>Belmont-Raytheon</i> , 20AY21 .....	44
black, <i>Arvin</i> , TE-272-1, TE-272-2, T-276 .....	29	<i>Capehart-Farnsworth</i> , CX-33 .....	52
black, on left-hand side of raster, see Barkhausen oscillation		see also Vertical circuit, improvement	
Vertical-centering control, adding, <i>Capehart-Farnsworth</i> , CX-30, A-2 and A-3 series .....	47-48	Vertical stability, improving, <i>Arvin</i> , TE-290-2 .....	34
Vertical circuit, improvement, <i>Calbest</i> , 16-, 17-, and 20-inch rectangular and 19-inch round picture tube models .....	46	TE-300, TE-315 .....	35
Vertical drift, <i>DuMont</i> , RA-117 series .....	99	TE-300, TE-302, TE-315 .....	34
Vertical foldover, <i>Admiral</i> , 20T1, 20V1, 21B1 through 21E1, 21H1, 21J1 .....	5-6	<i>Capehart-Farnsworth</i> , CX-33DX .....	65
20X1 through 20Z1 .....	10	see also Vertical circuit improvement	
21D1 .....	16	Vertical sync buzz, see Buzz, vertical sync intermittent, see Buzz, vertical sync	
Vertical-hold control, centering range of, <i>Belmont-Raytheon</i> , 20AY21 .....	44-45	Vertical sync, improving, <i>Capehart-Farnsworth</i> , CX-33DX .....	64
increasing range of, <i>Capehart-Farnsworth</i> , CX-33 .....	54	Vertical sync loss, see Sync noise immunity	
see also Vertical stability, improving		Vertical sync take-off point, see Interlace, improving	
Vertical jitter, correcting, <i>DuMont</i> , RA-101, RA-102, RA-103 .....	78-79	Vertical triggering, see Noise, improving immunity to vertical triggering	
RA-103D, RA-104A, RA-110A .....	83	Video i-f bandpass, improving, <i>DuMont</i> , RA-117 series .....	98
RA-105B, RA-108A .....	86-87	adjustment, <i>DuMont</i> , RA-109A, RA-111 series...	89
RA-105B, RA-108A .....	87	Video i-f transformer, defective, <i>DuMont</i> , RA-112 series, RA-113 series .....	96
Vertical linearity, improving, <i>Air King</i> , 700-10, -20, -30, -40, -50... ..	25	Video ringing, see Noise, improved immunity to impulse-type noise	
<i>Belmont-Raytheon</i> , 7DX22-P .....	38-39	Volume control, preventing from becoming noisy, <i>DuMont</i> , RA-103D, RA-104A, RA-110A .....	82
<i>Capehart-Farnsworth</i> , CX-33DX .....	63-64	<b>W</b>	
<i>Crosley</i> , 10-419MU, 10-427MU .....	74	Warm-up time, long, <i>Admiral</i> , 20T1, 20V1, 21B1 through 21E1, 21H1, 21J1 .....	4
<i>DuMont</i> , RA-109A .....	91	Weak signal, see AGC circuit change for high- noise areas; see also Sensitivity, increasing for fringe-area operation	
see also Picture height; Vertical foldover		Weak signal areas, increasing sensitivity, see 300-ohm input adaptation,	
Vertical lines, elimination of, see Oscillator, spill-over			
Vertical retrace lines, blanking (or eliminating), <i>Arvin</i> , TE-302-5, TE-315-4 .....	36		

	<i>Page</i>	<i>Page</i>	
see Fringe-area operation, modifications for improved operation,			
see Horizontal multivibrator, stabilized,			
see Local-distance switch, installation of,			
see Noise pulse, high amplitude,			
see Noise rejection, sound section, improvement,			
see Regeneration,			
see Sensitivity, increasing,			
see Snow,			
see Sync noise immunity,			
see Vertical stability, improving			
<b>Weaving,</b>			
see Horizontal tearing			
<b>Whistle, high-frequency,</b>			
see Sound, whistle in, reducing			
<b>White coating on aquadag surface,</b>			
see Aquadag			
<b>White lines, diagonal,</b>			
see Horizontal drive control, prevention of squegging			
<b>Width coil,</b>			
breakdown of capacitor shunting width coil,			
<i>Arvin</i> , 12½-inch chassis .....	37-38		
see Picture width, radiation,			
		see also Interference, radio, from horizontal sync	
		Width reduction,	
		see Horizontal scan, intermittent decrease	
		see also Yoke, apparent failure	
		Wobble, horizontal,	
		see Horizontal instability	
		<b>Y</b>	
		<b>Yoke,</b>	
		apparent failure,	
		<i>Belmont-Raytheon</i> , 14AX21 .....	41
		replacement,	
		<i>Belmont-Raytheon</i> ,	
		16AY28, 16AY211,	
		17AY24, 17AY27,	
		20AY21 .....	42
		stuck,	
		<i>DuMont</i> , all models .....	101-102
		windings, preventing voltage breakdown,	
		see High-voltage breakdown between yoke windings	

# These **RIDER** books make TV servicing **EASY!**

## **TV TROUBLESHOOTING AND REPAIR GUIDE BOOK, VOL. 1**

by Robert G. Middleton

Know how to recognize TV receiver troubles and cure them. This book shows you how through the use of pictures taken directly from TV receiver picture tubes and scopes. Valuable troubleshooting charts are also given. Not a theory book — but a practical troubleshooting and repair guide guaranteed to save hours of time-consuming labor. 204 pages, 8½ x 11", illus. *Only \$3.90*

## **RECEIVING TUBE SUBSTITUTION GUIDE BOOK**

by H. A. Middleton

Answers all tube problems by listing 2,500 radio-television tube substitutions in numerical sequence with accompanying wiring instructions, original and substitute tube socket illustrations. It helps you turn out jobs that would otherwise remain on the shelf because of lack of proper tubes. 224 pages, 8½ x 11". *Only \$3.00.*

## **FIRST SUPPLEMENT, RECEIVING TUBE SUBSTITUTION GUIDE BOOK**

by H. A. Middleton

750 completely new and different radio-TV tube substitutions not listed in the first edition. Special section on substituting tubes in television receivers. 48 pages, 8½ x 11". *Only 99¢.*

## **To be Published Soon**

### **TV MANUFACTURERS' RECEIVER TROUBLE CURES, VOL. 2**

The second volume in this series of practical books that gives exact directions for correcting TV receiver performance "bugs." Each remedy is developed by the receiver's own manufacturer. Covers 11 prominent brands not included in Volume 1. *One service job will more than pay the cost of the book.* Over 100 pages, 5¼ x 8¼", illustrated. *Only \$1.80.*

### **TV SWEEP ALIGNMENT TECHNIQUES**

by Art Liebscher

Never before has there been such a book on this important subject. Exclusive information and material not generally available to service technicians is included. The new *Supermark* method is introduced. The author is a famous test equipment specialist. Over 100 pages, 5¼ x 8¼", illus. *Only \$2.10*

**JOHN F. RIDER PUBLISHER, INC., 480 CANAL ST., N. Y. 13, N. Y.**



# ADV Plans, LLC

## Copyright Notice:

The entire contents of this CD/DVD are copyright 2014 by ADV Plans, LLC. All Rights Reserved.

Reproduction or distribution of this disk, either free or for a fee is strictly prohibited. We actively monitor and remove listings on eBay thru Vero.

You are free to copy or use individual images in your own projects, magazines, brochures or other school projects.

Only the sellers listed here are authorized distributors of this collection:  
[www.theclassicarchives.com/authorizedsuppliers](http://www.theclassicarchives.com/authorizedsuppliers)

Please view our other products at  
[www.theclassicarchives.com](http://www.theclassicarchives.com),  
or our ebay stores:

[TheClassicArchives](#)  
[ADVPlans](#)  
[SuperShedPlans](#)

