

TV

MANUFACTURERS' RECEIVER TROUBLE CURES

VOLUME 2

(Cat. No. 143-2)

Emerson
Fada
Firestone
Freed
Gamble-Skogmo
General Electric
Hallicrafters
Hoffman
Industrial TV
International TV
Jackson

A RIDER Publication

\$180

Copyright 1953 by

JOHN F. RIDER PUBLISHER, INC.

*All rights reserved including that of translation into
the Scandinavian and other foreign languages.*

Printed in the United States of America

P R E F A C E

This is the second in a series of volumes which deals with specific tv receiver troubles and their cures. These trouble cures are the tv manufacturers' answers to some of the problems that may arise in their particular receivers.

After a certain model or chassis has been in the field for a while, certain troubles may occur which are peculiar to that receiver. In an effort to maintain his own good reputation, the manufacturer is interested in keeping his receiver in tip-top working order. Therefore, his service or engineering department evolves a cure for the particular trouble.

The question may be asked, "Why doesn't the manufacturer incorporate the cure into future production runs of his own receiver?" The answer is that he frequently does. However, it is certainly not possible, with such a complex device as a tv receiver, to hold off on production until every single "bug" has been removed. The fact remains that many receivers are in the field and do develop certain peculiarities of operation for which the manufacturer has a definite tried-and-tested cure. Many of these cures will be found in this volume.

In addition, the development of new ideas and circuitry is unending. These new ideas are conceived by tv receiver manufacturers and many of the circuits can be incorporated into receivers already in the field. Such changes will improve the operation of the receiver, especially under unusual or difficult operating conditions. What is more, in areas of high humidity, in fringe areas, in strong-signal areas, etc., certain troubles are apt to occur. Many of the manufacturers' trouble cures given in this volume will alleviate these troubles when properly applied to the receiver in question.

You will note that this volume contains valuable information relating to trouble cures and circuit changes which will actually improve the operation of the tv receiver. You will not be given generalized instructions to "check this capacitor" or "check that tube" if a certain trouble appears. Instead, you will be given exact directions as to the specific operation to be performed in affecting the cure. In all cases where components are identified, the manufacturer's own circuit symbol number is used. This makes it easy to utilize the information given in these pages along with *Rider Manuals* and *Tek-File*. A complete index in which trouble cures are listed by brand and chassis or model number appears at the end of this volume.

The editor wishes to acknowledge the cooperation of the following tv receiver manufacturers who furnished the information contained in this volume to John F. Rider Publisher, Inc.

EMERSON

FADA

FIRESTONE

FREED

GAMBLE-SKOGMO

(Coronado)

GENERAL ELECTRIC

HALLICRAFTERS

HOFFMAN

INDUSTRIAL

INTERNATIONAL

JACKSON

February, 1953

Milton S. Snitzer

CONTENTS

MANUFACTURER	CHASSIS OR MODEL	PAGE
EMERSON		1-19
	120084-B	1
	120095-B	1
	120118-B	1-2
	120123-B	1-3
	120124	4
	120127-B	4-7
	120128-B	4-7
	120129-B, -D	7-11
	120131-B	2
	120133-B	1-2, 11
	120134-B, -G	8-9, 11-13
	120135-B	7-9
	120135-G, -H	7
	120138-B	1, 2, 13
	120140-B, -G, -H	7-8
	120141-B	4-5, 7
	120141-G, -H	7
	120142-B	13-16
	120143-B	13-15
	120144-B	8
	120144-G, -H	7-9
	120148-B	13-14
	120153-B	16-18
	120158-B	16, 18-19
	130135-B	11-12
	140143-B, -H	15-16

MANUFACTURER	CHASSIS OR MODEL	PAGE
FADA		19-21
	R-1025	19
	R-1050	19
	S6T65	19-20
	S7C20	19-20
	S7C30	19-20
	S7T65	19-20
	S20C10	19-20
	S20T20	19-20
	S-1055, S-1055X	19-21
	S1060	20-21
FIRESTONE		21-24
	13-G-44, -45, -46, -47, -48	21-23
	13-G-49, -50	23
	13-G-51, -52	21, 23-24
	13-G-53, -54, -55	23
	13-G-59	23
	13-G-79	23
	Models using Hytron picture tubes	24
FREED		25-30
	1610	25-27
	1620 series	25-27
	1620A	27
	1620B	27-28
	1620C	27-29
	1900	28-29
	1916	25-29
	Chassis with metal picture tubes	29-30
	All chassis	30
GAMBLE-SKOGMO (Coronado)		30-33
	05TV1-43-8945A	30
	05TV1-43-9005A, -9006A	30
	05TV1-43-9014A	31
	05TV2-43-8950A	31
	05TV2-43-9010A	31
	05TV2-43-9010B	31-32
	15TV2-43-9012A, -9013A	31-32
	94TV1-43-8940A	33

MANUFACTURER	CHASSIS OR MODEL	PAGE
GENERAL ELECTRIC		33-54
	10C101, -102	33
	10T1	33-34
	10T4, -5, -6	33-34
	12C107, -108, -109	33-34
	12K1	33-35
	12T3, -4	33-34
	12T7	33-35
	14C102, -103	36-39
	14T2, -3	36-39
	16C103, -104	36-37
	16C110, -111	35, 37-40
	16C113	36-39
	16C114	36-37
	16C115	35, 37-40
	16C116	37-39
	16K series	35-36
	16K1, -2	36, 38-41
	16T series	35-36
	16T1, -2	35, 37-40
	16T3, -4, -5, -6	36-37
	17C series	35-36
	17C101, -102	36
	17C110, -111	41-43
	17C113, -115, -117, -120	43-45
	17T series	35-36
	17T7	43-45
	19C101	45
	800 series	46
	801, 802, 803	46-47
	805, 806, 807, 809	46, 48
	810, 811, 814	46-51
	817	46-48
	818	34-35, 48
	820	46-48, 51-52
	821	46, 48
	830, 835	46-49, 51
	840	46-48, 52
	901, 910	52
	All models	53-54
	All models using series filaments	53
	Models with "B-version" head-end unit	52-53

MANUFACTURER	CHASSIS OR MODEL	PAGE
HALLICRAFTERS		54-56
	T-54	54
	T-60	54
	T-64	54-55
	T-67, -68	54
	505	54
	509	54-55
	1002	55-56
	1007	55-56
	1015, 1016, 1017, 1018, 1019	55-56
	All 10-inch picture tube models	56
HOFFMAN		56-100
	135	56-59
	140, 142	59-68
	143	59-65, 68-70
	146	59-68, 70-71
	147	59-65, 68-69
	149, 150	68
	151	68-69
	152	69
	153	71
	154	68
	156, 157	71-73
	159, 160	71-81
	164	71-73
	170, 171, 172, 173, 174, 175, 176	73-75, 81-92
	180	73-75, 81-84
	183	73-75, 81-84, 92
	184, 185, 186	73-75, 81-84
	187	73-75, 81-84, 92-94
	187B	92-94
	187C	92-93
	Mark IV chassis	94
	Models with RF-1 head end	94
	Models with RF-2 head end	94-95
	Models with RF-3 head end	95-96
	Chassis with turret tuners	
	RF-3, RF-4, RF-5, RF-6	96
	All 10-, 12-, 16-, and 19-inch chassis	96-98
	All chassis with 16-inch picture tubes	98
	All chassis with signal-keyed agc	98-99
	All chassis	99-100

MANUFACTURER	CHASSIS OR MODEL	PAGE
INDUSTRIAL		100-108
	IT-1R	100-101
	IT-1R-2	102
	IT-1R-20"	102
	IT-3R	102
	IT-11R	102
	IT-13R	102
	IT-21R	103-105
	IT-21R-1-2	102-103
	IT-35R	106
	All chassis	106-108
INTERNATIONAL		108-109
	F-16	108-109
JACKSON		109-110
	114G	109-110
	116G, 117G	109-110
	120G	109-110



EMERSON Chassis 120084-B
Discoloration of mirror in optical box.

Due to the high voltage under which the picture-tube anode in this unit operates, a small amount of ozone is generated and, in conjunction with microscopic impurities in the mirror glass, can result in spotting of the 45-degree plane mirror. In order to prevent this from happening, a simple procedure which consists of cleaning only is recommended. This cleaning procedure, if followed every six months, should prevent tarnishing and discoloration.

The 3NP4 picture tube should be removed from the optical box and the high-voltage anode connector removed from the glass cup on the tube. The inside of the glass cup should be cleaned thoroughly with a brush saturated in carbon tetrachloride. The grounding clips which make contact with the aquadag coating of the picture tube should also be cleaned in the same manner. After drying by evaporation, the tube can be reinstalled in the optical box. Care should be exercised in handling the tube to reduce hand contact at the high-voltage cup to a minimum.

EMERSON Chassis 120095-B,
 120123-B, 120133-B,
 120138-B

Increased i-f bandpass (see Fig. 1).

Performance can frequently be improved if the 25.75-mc picture i-f marker and the 22.5-mc i-f bandpass marker appear at the 50% response

point instead of the 75%-down point as shown previously in the service notes for the above chassis. When modified the over-all i-f response curve should appear as shown in the figure.

With 10-mc sweep width, the output from the sweep generator should be adjusted to produce about .5 volt dc across the detector load (*R-39*, 4,700 ohms).

Note: The above is particularly helpful when other expedients fail to minimize effects caused by station modulation variations.

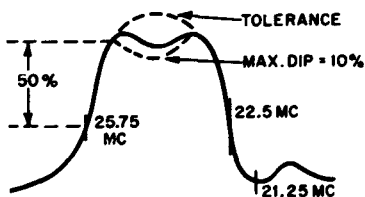

Fig. 1 — Emerson

EMERSON Chassis 120118-B
Reduction of horizontal foldover.

To reduce horizontal foldover, proceed as follows:

1. Disconnect *C-73*, (5- μmf capacitor in horizontal oscillator feedback circuit) from junction of *C-47* (.002 μf), *C-46* (68 μmf), and *C-45* (150 μmf).

2. Insert 47,000-ohm resistor between *C-73* and junction of *C-47*, *C-46*, and *C-45*.

3. Insert 68- μmf capacitor from junction of *C-73* and new 47,000-ohm resistor to 8 minus.

EMERSON Chassis 120118-B
Improving picture sharpness and contrast.

1. Change 33,000-ohm resistor *R-16*, connected from pin 2 to pin 5

of the 6AL5 video detector to a 68,000-ohm resistor.

2. Change the 47- μmf capacitor *C-13*, connected from pin 2 to pin 1 of the 6AL5 video detector to a 24- μmf capacitor.

3. Change the 6,800-ohm resistor *R-15*, which is connected between the low end of the secondary of the 3rd video i-f transformer and the low end of the peaking coil which runs to pin 7 of the 6AL5 video detector, to a 4,700-ohm resistor.

EMERSON Chassis 120118-B **Loss of horizontal sync.**

If the picture falls out of horizontal synchronization and the procedure for this alignment, as outlined in the service notes, fails then one of the following will very often remedy the trouble:

1. Replace horizontal oscillator and control tube *V-13* (12SN7GT).

2. Replace *C-47* (.002- μf , 400-volt capacitor) with a 600-volt capacitor of the same value. The former capacitor usually causes a constant and gradual shift of frequency-slug adjustment until slug will not make the range.

3. Replace *T-7* horizontal oscillator and phasing coils. A defect here usually shows up as bad arcing and a small irregular raster.

Note: If picture is out of sync both horizontally and vertically, but can be synchronized manually for short periods of time, the trouble is very likely due to a defect in the sync amplifiers or clipper stages.

The above information can also be applied to any Emerson chassis using this method of horizontal automatic frequency control.

EMERSON Chassis 120123-B, 120131-B, 120133-B, 120138-B

Removing neck shadows.

If it is impossible to center the picture properly without a resultant shadow on the right-hand side of the picture-tube screen, proceed as follows:

1. Check capacitor *C-61* (.5- μf blocking capacitor to horizontal-deflection windings of yoke) and replace if shorted.

2. Magnetize the metal band around the deflection yoke in the following manner: The negative terminal of an 8- μf electrolytic capacitor is connected to B-neutral (switch on rear of volume control). With the set operating, momentarily touch the positive side of this electrolytic to the junction of *C-61* and red lead to the horizontal-deflection winding (located on lug farthest from front of chassis on terminal board near volume control). The picture will jump from left to right and settle to a position slightly farther right than it was originally. If necessary, discharge capacitor to B-neutral and repeat operation, being careful not to overdo and cause a shadow on the lower left-hand side of the picture tube.

EMERSON Chassis 120123-B **Intercarrier buzz (see Fig. 2).**

To nullify the effects of intercarrier buzz, proceed as follows:

Remove following components from circuit:

1. *C-21* (110 μmf) connected between pin 5 and pin 2 of *V-6* (6S8).

2. Two 100-k (*R-19*, *R-20*) resistors from lug 5 of discriminator transformer (*T-6*).

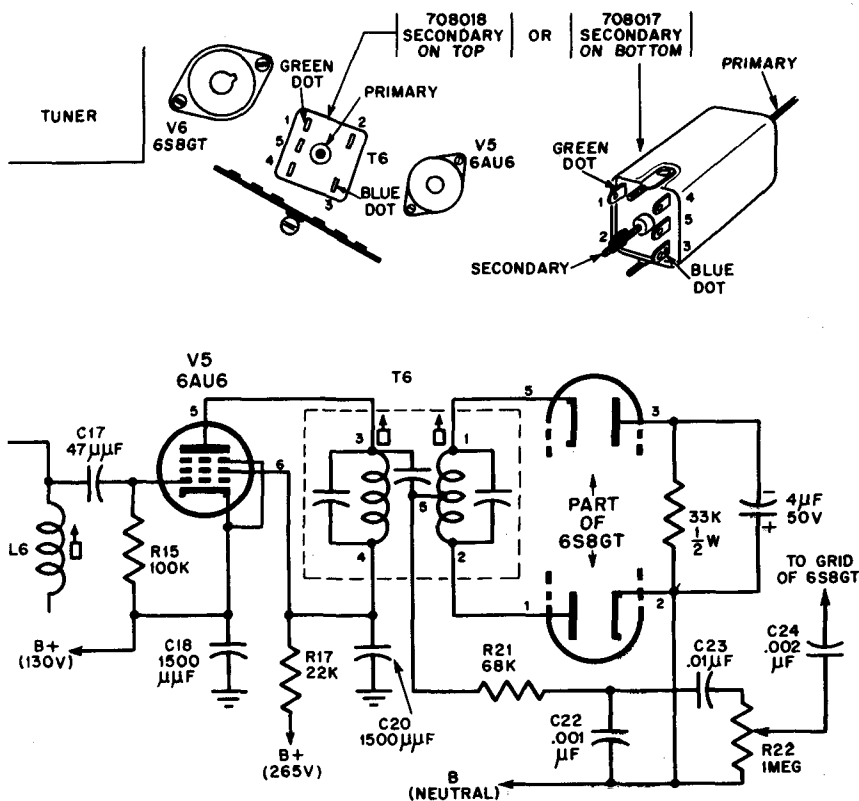

Fig. 2 — Emerson

3. *R-16*, *C-19* (8,200 ohms and 1,500 μmf) from pin 6 of *V-5* (6AU6).

4. *R-18* (2,200-ohm) resistor from B+ point on terminal strip to lug 4 of *T-6*.

Reconnect the following components:

5. Remove pigtail of *R-21* (68 k) going to pin 5 of 6S8 and connect to lug 5 of *T-6*.

6. Remove lead from pin 3 of *V-6* (6S8) and connect to pin 5 of *V-6*.

7. Add a jumper wire from lug 4 of *T-6* to pin 6 of *V-5* (6AU6).

Add the following components:

8. Place a 33-k, $\frac{1}{2}$ -watt resistor in parallel with a 4- μf , 50-volt electrolytic capacitor, part No. 925070-2 and connect from pin 3 of *V-6* (6S8) to neutral on nearby terminal board (2nd lug from tuner) with negative side of electrolytic to pin 3, *V-6* (6S8).

9. Add a .001- μf , 400-volt capacitor from pin 6 of *V-6* (6S8) to B neutral.

Sound alignment.

10. Place a VTVM (negative scale) across the 4- μf electrolytic, ground terminal to B neutral (positive side of electrolytic).

11. Tune in a strong television station.

12. Adjust *L-6* and primary of *T-6* for maximum meter deflection.

13. Remove meter and adjust secondary (*T-6*) for maximum sound with minimum buzz.

Note: If buzz is not eliminated try changing the 6S8 tube and then repeat sound alignment.

EMERSON Chassis 120124
Reducing interference to a-m broadcast sets.

In the event subject chassis causes interference on a-m radio sets the following change will eliminate it:

1. Add a .05- μ f, 400-volt capacitor from line switch side of a-c input plug.

2. Add a 100,000-ohm, 1-watt resistor in parallel with above capacitor.

EMERSON Chassis 120124
Reducing internal-radiation effects on sync stability.

To reduce internal-radiation effects on sync stability, proceed as follows:

1. Remove lead from junction of *R-6* (1k ohms), *R-31* (1 meg), *C-37* (.25 μ f), to *V-8* (6T8) pin 6.

2. Add 1,500- μ mf capacitor from B+ side of fuse (*F-1*), to chassis, leads $\frac{1}{4}$ inch long.

3. One side of *R-35* (100 k) now goes to chassis instead of pin 7 of *V-4*, 6AU6.

4. Remove 225-volt B+ lead from fuse to dummy lug under *T-8* horizontal-oscillator transformer.

5. Add B+ lead from fuse on dummy lug through high-voltage box and

along top of chassis to chassis hole near power transformer, then through this hole to positive lug of *C-51* (square-coded lug).

6. Remove secondary leads of vertical-output transformer (*T-7*) from dummy lug under deflection yoke.

7. Reroute leads through high-voltage box and along top of chassis, then solder back to same dummy lugs. These lugs also hold leads from vertical-deflection coils (*L-8*).

8. Reroute lead from horizontal-size coil (*L-11*) to horizontal-deflection coil (*L-9*) through high-voltage box and along top of chassis.

9. Add metal shield 4 inches long by 2 inches wide along the side of i-f dummy-lug strip.

10. Change *C-73* from 50- μ mf mica capacitor to 42- μ mf ceramic 2,000-volt capacitor (part No. 928058).

Later production runs already include these changes.

EMERSON Chassis 120127-B,
120128-B, 120141-B
Reduction of picture-carrier beats on channel 5.

The following changes will reduce picture-carrier beats on channel 5:

1. Move 1,500- μ mf ceramic capacitor from common ground connection near 6CB6 tube socket (*V-3*) to common ground connection near 6AL5 tube socket (*V-4*).

2. Remove *C-14* (5,000- μ mf) capacitor from present location and reconnect from pin 2 of 6AU6 (*V-6*) to chassis (between power transformer and *V-6* socket).

3. Add a 5,000- μ mf ceramic capacitor from pin 6 (*V-5*) to common chassis connection near socket.

4. Anchor a-c wires from switch to wall of chassis near bottom edge adjacent to chassis mounting feet.

5. Place a shield over 6AL5 video detector (V-4).

Sets coded Triangle 6 already have the above changes.

EMERSON Chassis 120127-B,
120128-B

Centering range of vertical-hold control.

The following changes are made to improve the mechanical centering of the vertical-hold control in producing vertical synchronization:

1. R-35 (in cathode circuit of sync phase inverter) is changed from 220 ohms, 1/2 watt to 150 ohms, 1/2 watt.

2. R-64 (in series with vertical-hold control) is changed from 680 k, 1/2 watt to 1 meg, 1/2 watt.

EMERSON Chassis 120127-B,
120128-B

Removing neck shadows.

In some rare instances it might be impossible to center the picture properly without a resultant shadow on the right-hand side of the picture tube (facing front of set). If the proper adjustment of the beam bender (for maximum brightness), focus coil, and deflection yoke (push yoke toward front of picture tube making sure front of coil rests against bell) does not eliminate this shadow, then the following procedure will easily remedy this condition.

1. Reverse electrical connections to the focus coil making sure the picture-tube neck is properly centered in the deflection yoke and focus coil.

2. If step 1 does not eliminate this shadow, magnetize the molded iron core in the deflection yoke by the following method:

a. Remove V-15 (6BG6), V-17 (1B3) and V-16 (6W4) from their sockets.

b. Remove the white lead from horizontal-deflection yoke at width coil (junction L-11 and R-91) and connect to B+ 230-volt point (red lead on electrolytic capacitor).

c. Connect the negative terminal of a spare 40- μ f, 450-volt electrolytic capacitor to chassis.

d. With the set operating, momentarily touch the positive side of this electrolytic to pin 3 of the 6W4 (V-16) damper tube socket.

e. Remove this 40- μ f, 450-volt electrolytic from set, first making sure to discharge positive terminal to chassis in order to avoid chance of shock.

f. Replace tubes and reconnect yoke lead.

If shadow persists repeat above procedure. In extremely stubborn cases the fault might lie in the picture tube or deflection yoke. Exchanging either of these components will then eliminate the trouble.

EMERSON Chassis 120127-B,
120128-B

Improving vertical-sync stability.

In order to improve the vertical-sync stability, add a 10k-ohm, 1/2-watt resistor (R-93) between C-29 (.047- μ f coupling capacitor between the sync amplifier and the sync separator) and the junction of R-40 (2.2 meg), C-28 (110 μ f), and R-41 (100k ohm). Sets coded Triangle 5 incorporate this change.

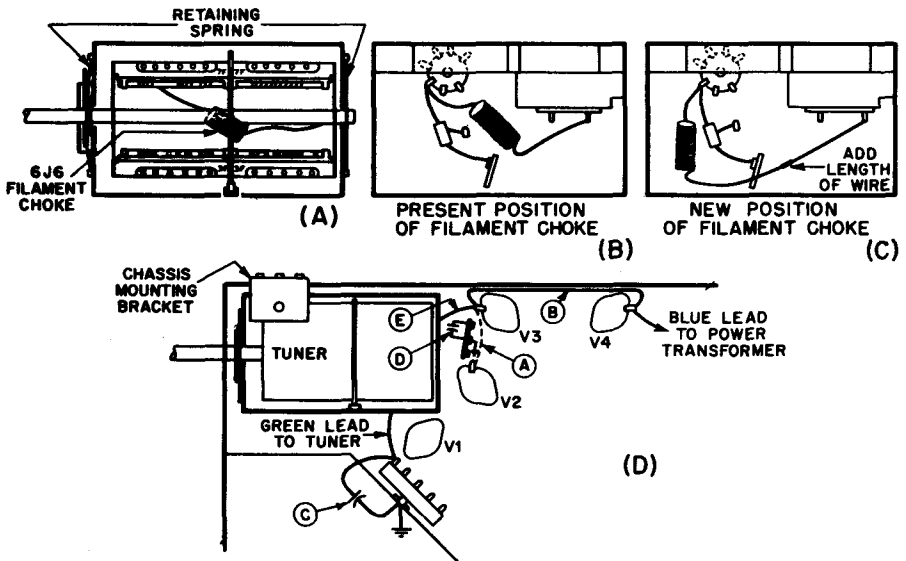

Fig. 3 — Emerson

EMERSON Chassis 120127-B,
120128-B

Reducing effects of Barkhausen oscillation (see Fig. 3).

In certain areas, due to various local conditions, it might be difficult and time consuming to eliminate this interference by normal means; such as adjusting horizontal-drive capacitor or changing 6BG6. In these cases the following simple procedure used in conjunction with the above steps will eliminate or reduce this interference to a negligible amount.

Break the cement which glues the 6J6 filament choke to the underside of the tuner chassis (see part (A) of figure) and dress away from chassis (towards turret). This can be accomplished by removing both sets of coils for channels 4, 5, 6, 11, 12, and 13, and then gently prying the choke loose with a screwdriver. Be careful not to damage or change the shape of the coil.

If the above procedure does not reduce the Barkhausen interference to a negligible amount, then the following more complete procedure will eliminate this condition.

1. Remove turret from tuner by removing fibre shaft support, metal chassis mounting bracket, and the two turret retaining springs (located in front and rear of tuner chassis).

2. Reposition filament-choke coil as shown in part (C) of figure, making sure to keep choke and pigtails raised from chassis. This will necessitate the addition of an extra length of wire.

3. Refer to part (D) of figure in making changes listed below:

- a. Remove heater wire (shown dotted).

- b. Add new heater wire (keep off chassis).

- c. Add 1,500- μmf capacitor to bypass agc line.

d. Add 1,500- μmf capacitor to bypass tuner B+.

e. Raise tuner filament wire off chassis.

EMERSON Chassis 120127-B
To increase horizontal width.

In order to increase the horizontal width which has been reduced as a result of slight component variations, proceed as follows:

1. C-70 (connected to horizontal-linearity coil) is changed from .018 μf , 1,000 volts to .022 μf , 1,000 volts.

2. A 50- μmf , 4,000-volt capacitor is added from pin 3 of V-16 (6W4 damper tube) to junction of horizontal size coil, R-91 (750-ohm, 10-watt resistor) and wired to pin 1 of deflection yoke.

EMERSON Chassis 120129-B, -D,
 120135-B, -G, -H, 120140-B,
 -G, -H, 120141-B, -G, -H

Improving sync stability in fringe areas (see Fig. 4).

The following changes may be made to improve sync stability in fringe areas:

1. Remove R-58 (10 k, $\frac{1}{2}$ watt), plate resistor of 1st sync separator.

2. Connect a 4,700-ohm, $\frac{1}{2}$ -watt resistor in series with a 2,200-ohm, $\frac{1}{2}$ -watt resistor in place of R-58 (4,700 ohms is connected to pin 6 of V-10).

3. Remove pigtail of C-57 (.05 μf) which went to pin 6 of V-10 and connect to junction of 4,700-ohm and 2,200-ohm resistors.

4. Change R-61 from 220 ohms to 330 ohms, $\frac{1}{2}$ watt. This resistor is in the plate circuit of the sync-output amplifier.

Later production runs include these changes as shown in the figure.

EMERSON Chassis 120129-B, -D,
 120140-B, -G, -H,
 120144-B, -G, -H

Improving sync stability in fringe areas (see Fig. 5).

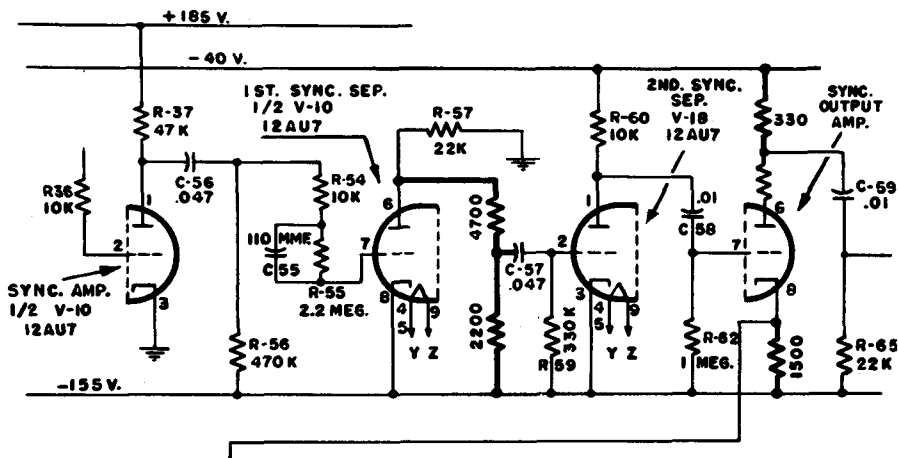
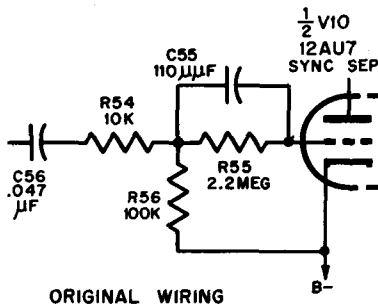
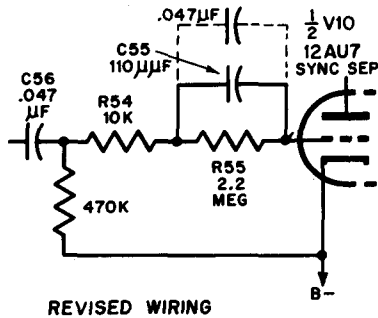

Fig. 4 — Emerson



ORIGINAL WIRING



REVISED WIRING

Fig. 5 — Emerson

The following changes should be made to improve sync stability in fringe areas. Chassis already incorporating this change have the letter *E* stamped inside the code triangle.

Change *R-56* from 100 k to 470 k, ½ watt, repositioning pigtail from junction of *R-54* (10 k), *R-55* (2.2 meg), *C-55* (110 μμf), to junction of *C-56* (.047 μf), *R-54* (10 k) as per figure.

In extreme fringe areas where little external noise is encountered, a .047-μf capacitor may be shunted across *C-55* as shown dashed in the figure.

EMERSON Chassis 120129-B, -D,
120140-B, -G, -H,
120144-B, -G, -H

Preventing vertical foldover.

To prevent vertical foldover, change *R-77* in plate circuit of vertical-discharge tube from 10,000 ohms, ½ watt to 12,000 ohms, ½ watt.

Sets coded Triangle V already have this change.

EMERSON Chassis 120129-B, -D,
120140-B, -G, -H, 120144-B

Centering range of vertical-hold control.

In order to allow proper vertical synchronization to occur toward the mechanical center position of the vertical-hold control, change *R-71* (in series with the hold control) from 470,000 ohms to 680,000 ohms, ½ watt.

Later production runs of these sets already have this change.

EMERSON Chassis 120129-B,
120134-B, -G, 120135-B

Improving sync stability in fringe areas (see Fig. 6).

To improve the sync stability in extreme fringe areas, proceed as follows:

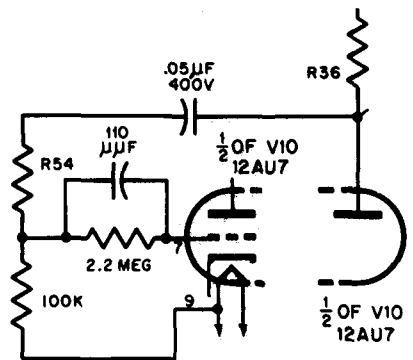

Fig. 6 — Emerson

1. *R-36* (in plate circuit of sync amplifier) is changed from 10k ohms to 47k ohms.

2. *R-56* (3.3 meg) is removed. This resistor is in grid circuit of the sync separator.

3. *C-55* (220 $\mu\mu\text{f}$), *R-55* (330k ohms), and *C-56* (.01 μf) are removed. These are also in the grid circuit of the sync separator.

4. A 2.2-meg resistor in parallel with a 110- $\mu\mu\text{f}$ capacitor is added between pin 7 of *V-10* and *R-54* (old junction of *C-55* and *R-55*).

5. A .05- μf , 400-volt capacitor is added between pin 1 of *V-10* and *R-54* (10k ohms).

6. A 100k-ohm, $\frac{1}{2}$ -watt resistor is added from pin 9 of *V-10* to junction of *R-54*, 2.2-meg resistor, and 110- $\mu\mu\text{f}$ capacitor.

The complete change should alter the schematic as shown in the figure. Some sets in later production runs already contain this circuit modification.

EMERSON Chassis 120129-B, -D,
120144-B, -G, -H

To reduce vertical size.

To reduce vertical size which has become excessive due to component tolerances or high line voltage, make the following changes in the bleeder network which feeds the vertical-discharge tube:

1. *R-75* is changed from 220 k, $\frac{1}{2}$ watt to 150 k, $\frac{1}{2}$ watt.

2. *R-76* is changed from 150 k, $\frac{1}{2}$ watt to 220 k, $\frac{1}{2}$ watt.

Note that no new resistors are needed for this change. Chassis already incorporating this change are coded with a Triangle C.

EMERSON Chassis 120129-B, -D
Improving vertical interlace.

The following changes are made to improve vertical interlace. Chassis incorporating this change are coded with a Triangle D.

1. Omit *C-72* (270 $\mu\mu\text{f}$) which is located in deflection yoke.

2. Add a .047- μf , 400-volt capacitor from pin 6 of *V-1* to chassis.

3. Add a wire from pin 6 of *X-4* (deflection-coil socket) to junction of *C-94*, *C-93* and horizontal-size control.

Note: If the omission of *C-72* causes excessive rippling of the horizontal scanning lines, re-install this capacitor.

EMERSON Chassis 120129-B, -D
Improved agc in weak-signal areas.

Chassis coded Triangle F incorporate a new agc system. In certain weak-signal areas the picture on this chassis might appear abnormally poor. If this is the case, change the value of the 10-meg resistor which is connected to pin 1 of *V-5* (6AL5) to a 3.3-meg. If picture overloads as a result of too little agc, then increase this resistor value until the overload condition disappears.

Note: Before making this change be sure all tubes and circuits have been checked for normal operation.

EMERSON Chassis 120129-B, -D
Centering focus-control range.

Sets coded Triangle G incorporate the addition of an 18-k, 2-watt resistor from the junction of *C-49* (40 μf), *C-50* (40 μf), and *L-13* (filter choke) to the junction of red wire of *T-8* (sound-output transform-

er), C-35 (40 μ f), and R-46 (30-k, 2-watt resistor), in order to center focus control range mechanically. This resistor is only used on G coded chassis and is not incorporated in chassis of a later code. After replacing a picture tube on a Triagle G stamped chassis, it may be necessary to remove this resistor to maintain the proper focusing range.

EMERSON Chassis 120129-B, -D
Excessive horizontal size with high-line voltage.

In the event that the receiver has excessive horizontal size because of high-line voltage, proceed as follows to reduce horizontal size: R-100 (11 k, 4 watt), screen-grid resistor for horizontal-output tube, is changed to 2,700 ohms, 1 watt and repositioned so that pigtail which went to junction of fuse and linearity coil now is connected to chassis.

EMERSON Chassis 120129-B, -D
Modification of agc for fringe-area operation (see Fig. 7).

Proceed as follows to modify agc circuit for fringe-area operation:

1. Omit R-35 (100 k, $\frac{1}{2}$ watt). This resistor is connected to plate of agc detector.
2. Change R-34 (in plate circuit of video detector) from 22 k to 150 k.
3. Add a 1-meg, $\frac{1}{2}$ -watt resistor from pin 1 to pin 7 of V-5.
4. Remove pigtail of C-18 (25 μ f) from pin 1 of V-5 (6AL5) and connect to pin 7. Note: Wire directly to tube socket keeping stray capacitance and lead lengths to a minimum.
5. Add a 25- μ f ceramic capacitor from pin 1 of V-5 to chassis.
6. Move pigtail of R-31 (1 meg, $\frac{1}{2}$ watt) from pin 7 of V-5 to pin 2 of V-5.
7. Add a 10-meg, $\frac{1}{2}$ -watt resistor from pin 1 of V-5 to B+ 210 volts (C-51 square marking).

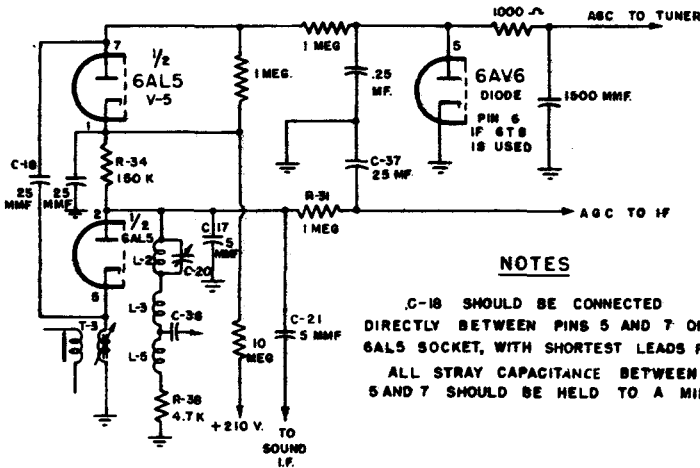

NOTES

- C-18 SHOULD BE CONNECTED DIRECTLY BETWEEN PINS 5 AND 7 OF 6AL5 SOCKET, WITH SHORTEST LEADS POSSIBLE.
- ALL STRAY CAPACITANCE BETWEEN PIN 5 AND 7 SHOULD BE HELD TO A MINIMUM.

Fig. 7 — Emerson

8. Change terminal strip near sound-output transformer from 3-lug to 5-lug strip.

9. Add a wire from pin 5 of 6AV6 to empty lug on new strip. If set uses a 6T8 use pin 6.

10. Connect a .25- μ f, 200-volt capacitor from the above point on terminal board to chassis.

11. Add a 1-k, $\frac{1}{2}$ -watt resistor between junction of added .25- μ f, 200-volt capacitor and lead to 6AV6 and additional empty lug on new strip.

12. Add a wire from this new point to tuner agc on terminal board near tuner.

13. Remove *R-3* (1,000 ohms, $\frac{1}{2}$ watt) from agc line.

14. Add a 1-meg, $\frac{1}{2}$ -watt resistor from pin 7 of *V-5* (6AL5) to pin 5 of 6AV6 (see step 9).

The diagram pictures the new agc circuit.

Chassis coded Triangle F already have the above modifications.

EMERSON Chassis 120129-B
Reduction of power-supply loading.

The following circuit changes are incorporated to reduce power supply loading.

1. Resistors *R-50* (8k ohms, 10 watts) and *R-46* (30k ohms, 5 watts), are removed. These resistors are positive-supply bleeder and focus-coil bleeder respectively.

2. *R-20* at pin 6 of *V-7* is changed from 27k ohms, 1 watt to 39k ohms, 2 watt and the pigtail which originally was connected to chassis now goes to junction of *R-108*, *C-36* (5,600 ohms, .005 μ f) in the sound-output stage.

3. *R-52* (1k ohm, 15 watt), positive-supply bleeder, is changed to 2k ohms, 4 watts.

4. *R-49* (4k ohms, 10 watts), negative-supply bleeder, is changed to 9k ohms, 4 watt.

5. *R-53* (1k ohm, 5 watts), negative-supply bleeder, is changed to 1.7k ohms, 4 watts.

Sets coded Triangle 3 already have these changes.

EMERSON Chassis 120133-B
To facilitate sound alignment.

The following changes are made to facilitate sound alignment:

1. *C-3* (front-end bypass) is changed from 1,500 μ f to .005 μ f, ceramic.

2. *R-14* in cathode of *V-4* is changed from 82 to 150 ohms, $\frac{1}{2}$ watt.

3. A 150-ohm, $\frac{1}{2}$ -watt resistor is inserted between pin 2 of *V-5* and B+ 130 volts.

4. A 470-ohm, $\frac{1}{2}$ -watt resistor is added from B+ 265-volt line to lug where *L-6* is connected.

These changes are already made in sets coded Triangle 3.

EMERSON Chassis 120134-B, -G,
130135-B

Horizontal sweep pick-up in video amplifier.

To reduce horizontal sweep pick-up in the video amplifier, wire the contrast control as follows:

1. Lead from cathode of video amplifier (*V-11*, 6AC7, pin 5) is wired to the outside lug on the contrast control.

2. The B-minus, 155-volt lead is connected in series with a 10-ohm, $\frac{1}{2}$ -watt resistor to the rotor lug on

the contrast control, and this lug is bypassed to chassis with a .25- μ f, 400-volt capacitor.

Sets coded Triangle 6 already have this change.

EMERSON Chassis 120134-B, -G
Poor picture and sound tracking in fringe areas (see Fig. 8).

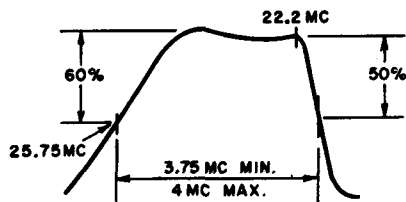

Fig. 8 — Emerson

Due to the additional selectivity provided by the continuous-type tuner, it has been found that the required amount of trap action is sometimes exceeded for good fringe-area sound and picture coincidence. To reduce the trap action when this condition is encountered, place a .01- μ f capacitor across the 21.25-mc sound trap (C-5 of T-1).

If the picture and sound coincidence is still in need of improvement, then the over-all i-f strip will have to be realigned to a minimum bandwidth of 3.75 mc as shown in the figure.

EMERSON Chassis 120134-B
Reducing ringing and blooming.

1. A jumper wire is used in place of L-3 (225- μ h video detector peaking coil).

2. The junction of R-46 (100k ohms), and R-47 (brightness pot) is connected to pin 6 of V-11 (6AC7) and then to B minus, -40 volt line.

3. R-46 (100k ohms) is omitted.

Sets coded Triangle 1 already have this change.

EMERSON Chassis 120134-B
Reducing i-f regeneration.

To reduce i-f regeneration a 20-microhenry choke is inserted between junctions of L-2, C-20 and R-36 (10k ohms), C-38 (.05 μ f), L-5 instead of a jumper wire.

Sets coded Triangle 2 or 3 already have this change.

EMERSON Chassis 120134-B
Improving audio quality in weak-signal areas.

In order to improve audio quality in weak-signal areas, proceed as follows:

1. Line between junction of L-4, C-22 (in V-6 grid circuit) and junction of R-17, R-32 is removed and a 1,500- μ mf capacitor is inserted in its place.

2. A 1-meg, 1/2-watt resistor is added between junction of L-4, C-22 and junction of T-4, R-18, C-24.

3. A 1,500- μ mf ceramic capacitor is added in parallel with R-17, the cathode resistor of V-6 (sound i-f amplifier).

4. The following values are changed:

R-32 (in cathode circuit of V-6) from 10 to 1,000 ohms, 1/2 watt.

C-16 (in cathode circuit of V-6) from .047- μ f to .005- μ f ceramic.

R-27 (plate load resistor of V-8) from 470 k to 220 k, 1/2 watt.

R-37 (plate resistor of sync amp.) from 10 k, 1/2 watt to 10 k, 1 watt.

5. C-26 and R-21 in plate circuit of V-7 is omitted.

6. The low side of the primary of *T-5* is grounded.

7. A 1,500- $\mu\mu\text{f}$ ceramic capacitor is added from pin 7 of *V-7* to chassis.

8. A 1,000-ohm, $\frac{1}{2}$ -watt resistor is inserted, instead of a jumper, between junction of *C-25*, *R-19*, *C-24*, *R-18* (in cathode circuit of *V-7*) and B-minus, 155 volts.

9. Connection of *R-27* (plate-load resistor of *V-8*) to B+, 185 volts is (in cathode circuit of *V-7*) changed to the B+, 225-volt point.

Chassis coded Triangle 4 have the above changes.

EMERSON Chassis 120138-B
Reducing effects caused by station modulation variation.

The following changes are incorporated to reduce the effects caused by station modulation variation and to make tuning easier:

1. *R-16* (8,200 ohms), *R-17* (22,000 ohms), *R-95* (1,000 ohms), and *C-19* (1,500 $\mu\mu\text{f}$) are removed from the sound-limiter and sound i-f amplifier circuits.

2. The junction of *C-20*, *R-18*, and *T-6* is connected to pin 6 of *V-5* (6AU6) by means of a jumper wire.

3. The value of *R-18* is changed from 2,200 ohms to 68,000 ohms, $\frac{1}{2}$ watt.

4. All leads to junction of *L-5* and *C-89*, *C-39*, *R-14*, and pin 2 of *V-4* are disconnected from one another and rewired as follows: (Note: *L-5* and *C-89* are left connected to one another.)

a. *R-14* (82 ohms) is wired to B+ (130-volt line).

b. Pin 2 of *V-4* (6AU6) is wired to pin 7 of the same tube.

c. *C-39* (1,500 $\mu\mu\text{f}$) is wired to pin 7 of *V-4*.

5. The following components are added:

a. A 1-meg, $\frac{1}{2}$ -watt resistor from pin 1 of *V-5* to junction of *L-5*, *C-89*.

b. A .01- μf , 200-volt capacitor from junction *L-5*, *C-89*, 1-meg resistor to pin 7 of *V-4* (6AU6).

c. A 33,000-ohm, 1-watt resistor from pin 6 of *V-8* (12AT7) to B+ (265-volt line).

EMERSON Chassis 120142-B,
120143-B, 120148-B
Improvement of vertical sync in fringe areas.

By changing the vertical sync take-off point from the cathode of the final sync amplifier to the output of the sync separator, a 2 to 1 improvement in vertical-sync amplitude will result. This is accomplished by disconnecting the pigtail of *C-40* (.05 μf) from pin 8 of *V-11* (12AU7) and connecting it to junction of *R-40*, *R-93*.

EMERSON Chassis 120142-B,
120143-B, 120148-B
Reduction of horizontal foldover (see Fig. 9).

To minimize horizontal foldover at the start of the picture trace, proceed as follows. (The effect is the appearance of white hash on the left side of the picture which varies with the setting of the horizontal-hold control.)

1. Replace *R-75* (220 k in afc feedback circuit) with two 100-k, $\frac{1}{2}$ -watt resistors in series.

2. Connect a 25- $\mu\mu\text{f}$ ceramic capacitor from the junction of the two

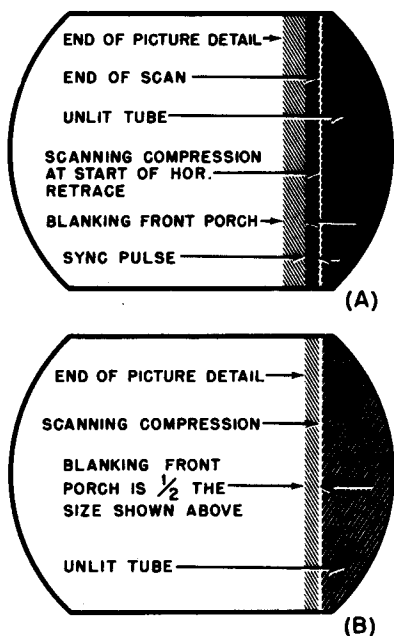

Fig. 9 — Emerson

100-k resistors to chassis, dressing the components away from the horizontal-phase and frequency coils.

3. When this is done the horizontal oscillator should be re-aligned in the following manner.

- a. Short out phasing coil.
- b. Rotate horizontal-hold control fully counterclockwise (be sure center tap is at lowest B-plus position).
- c. Starting with horizontal frequency slug all the way out, rotate in until picture just locks into sync.
- d. Adjust horizontal size and linearity if necessary; if picture falls out of sync repeat step c.
- e. Rotate horizontal hold $1/3$ away from minimum voltage position.
- f. Adjust centering so that right-hand edge of picture is visible while facing front of set.

g. Decrease contrast and turn up brightness while viewing a nicely received picture so that front horizontal blanking porch is visible (see part (A) of figure) on right hand side of picture.

h. Remove short across phasing coil and adjust until start of the horizontal-sync pulse is visible which is slightly blacker than the front porch.

Note the width of the front porch and then adjust phasing coil so that horizontal retrace occurs in the center of the front porch (see part (B) of fig.). At this position the horizontal-sync pulse is no longer visible at the right side of the picture since retrace has occurred before the start of horizontal sync.

Later production runs of the above chassis already have these changes.

EMERSON

Chassis 120142-B,
120143-B, -H

Modified agc for fringe-area operation (see Fig. 10).

The following changes may be made to improve performance, especially in fringe areas, by modifying the agc system to give a tuner delay. This modification will provide an increase in sensitivity.

1. Remove *R-15* (22k, $1/2$ watt) from pins 1 and 2 of *V-4* (6AL5), replacing it with a jumper wire.
2. Remove *R-16*, 100 k, which is connected from pin 7 of *V-4* to chassis.
3. Remove pigtail of *R-2* (470 ohms) resistor from lug on terminal board and reconnect to empty lug on same terminal strip. This resistor is in the grid circuit of *V-1*.
4. Add a white jumper wire from new position of *R-2* to the empty lug

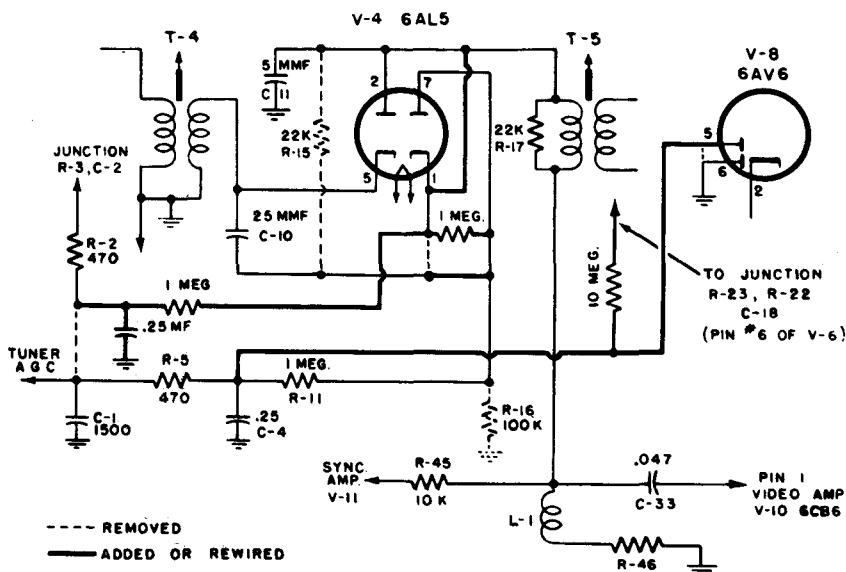

Fig. 10 — Emerson

on the terminal board near sound-output transformer.

5. Add a 1-meg, $\frac{1}{2}$ -watt resistor from this empty lug near audio-output transformer to pin 7 of V-4.

6. Add a .25- μ f, 400-volt capacitor from above point on terminal strip to chassis.

7. Remove pigtail of C-10 (25 μ f) from pin 1 of V-4 and connect to pin 7 of V-4.

8. Add a 1-meg, $\frac{1}{2}$ -watt resistor from pin 1 to pin 7 of V-4 (6AL5).

9. Remove all ground connections from pin 5 of V-8 connecting center shield pin to pin 6, if not already there.

10. Connect a white jumper lead from pin 5 of V-8 to junction R-5 (470 ohms), R-11 (1 meg), C-4 (.25 μ f) on terminal board near audio output transformer. These components are in the agc line.

11. Connect 10-meg, $\frac{1}{2}$ -watt resistor from above junction on terminal board to pin 6 of V-6.

When this revision is completed check circuit against the diagram.

Note: Due to agc change the following resistance measurements change appreciably. V-4 pin 1, 4.7 k; pin 7, 900 k. V-8 pin 5 changed to 1.8 meg.

Some later production runs already include these changes.

EMERSON Chassis 120142-B,
120143-B, -H

Reducing excessive vertical size.

In order to reduce excessive vertical size, change R-63 (in the plate circuit of the vertical oscillator) from 680k ohms to 1 meg. Sets coded Triangle F already have this change.

EMERSON Chassis 120142-B,
140143-B, -H

Added protection for power transformer.

The following changes are incorporated to give added protection to the power transformer in case of rectifier-tube failure. These changes should be made on all chassis which do not already incorporate them.

Pigtail of *R-55* (8.5 ohms) going to chassis is removed and connected to the chassis through a 1/2-amp, 250-volts fuse. The resistor is then connected between the center tap of the power transformer and ground by performing the following steps:

1. Replace 1/4-amp fuse with a jumper wire. This fuse is located on the underside of the chassis between the tuner and the high-voltage tubes.

2. Move one end of *R-55* (8.5 ohms, 5 watts) from chassis and connect to empty lug on terminal strip near power transformer.

3. Add an insulated jumper wire from this point to empty lug on terminal strip which is mounted on top side of chassis under the deflection yoke. Use hole in chassis between yoke-mounting brackets.

4. Add a 1/2-amp, 250-volts fuse, part No. 808001 from this lug under deflection yoke to chassis.

EMERSON Chassis 120142-B
Improving starting of horizontal oscillator at low line voltage.

The following changes are made to improve the starting of the horizontal oscillator at low line voltage. Sets incorporating this change are coded with a Triangle C.

1. *R-79*, in the plate-supply line of horizontal oscillator, is changed from 82,000 ohms, 1/2 watt to 68,000 ohms, 1/2 watt.

2. *R-76*, in series with the horizontal-hold control, is replaced by a

jumper wire which is connected to the B+ 230-volt point (end lug on brightness control) instead of chassis.

In addition to the above, check the following:

3. Check the 6AX5 tubes since they may have low emission causing low B-plus.

4. Try changing the 6BQ6. Try a few tubes, since some tubes have slow heaters.

5. Check *C-60*, the 10- μ f B-plus boost filter capacitor, and replace if leaky.

6. Be certain that all solder connections in *V-15* and *V-16* circuits are securely made.

7. In low line voltage areas change the value of *R-86* (in B-plus boost circuit) from 22 k to 15 k.

8. Try new phase coil *L-7* and oscillator transformer *T-10*, (may have intermittent open or shorted turn).

EMERSON Chassis 120153-B,
120158-B

Improving picture sync under adverse noise conditions.

In order to improve picture sync under adverse noise conditions, connect the pigtail of *R-39* (2.2-meg resistor in grid circuit of horizontal-sync amplifier) to the chassis instead of to the +150 volts line. Later production runs of the above chassis already have this change.

EMERSON Chassis 120153-B
Preventing oscillations at maximum contrast.

To prevent oscillations at maximum contrast which might interfere with the sound, proceed as follows:

1. Pigtail of *R-47* (1 meg) which was connected to the junction of

C-33 (.047 μf) and L-1 (250 μh), all in the grid circuit of the video amplifier, is connected to pin 1 of V-10 (6CB6 video amplifier).

2. A 33k-ohm, 1/2-watt resistor is added across L-1 (250- μh peaking coil).

Chassis coded Triangle A already have this change.

EMERSON Chassis 120153-B
Minimizing horizontal tearing on strong signals.

To minimize horizontal tearing on exceptionally strong signals, change C-30 (in grid circuit of the horizontal-sync separator) from 110 μf to 220 μf . This change is already made in chassis coded Triangle B.

EMERSON Chassis 120153-B
Addition of sound trap
(see Fig. 11).

A sound trap (part No. 720151) may be incorporated in the above

chassis if required. This trap is connected to the link of T-1B as shown in the figure, and is adjusted from the top of the chassis next to T-1B. To align this trap, feed a marker generator set at 21.25 mc to a floating mixer shield. Connect a VTVM to the junction of T-5, C-33, and R-46. The low side of the generator and the VTVM are both connected to the chassis. Temporarily place a jumper across sound trap T-3 bottom. Adjust L-9 for minimum response.

Chassis coded Triangle C already incorporates this trap.

EMERSON Chassis 120153-B
Preventing jitter in fringe areas
(see Fig. 12).

In fringe areas where there is a great deal of electrical impulse noise, such as ignition, neon signs, electric motors, etc., the picture might tend to jitter or continuously fall out of sync. To reduce this condition to a minimum this chassis has been incorporated with provisions for connect-

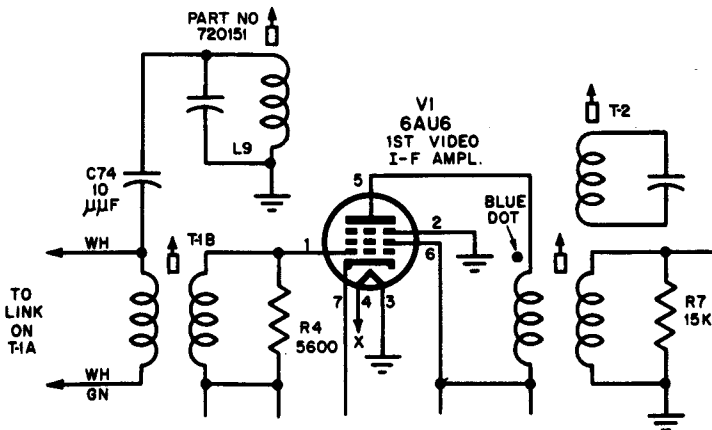

Fig. 11 — Emerson

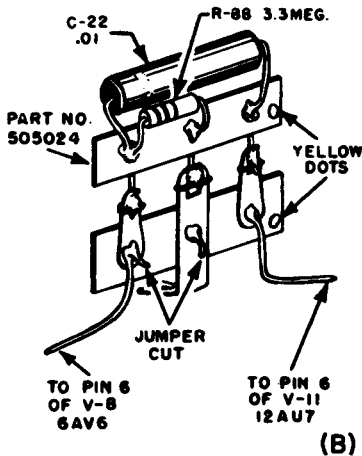
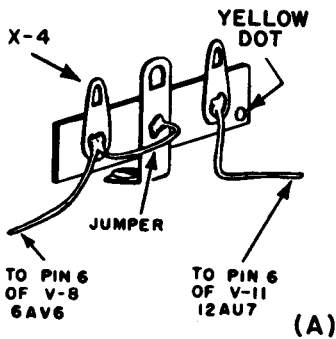

Fig. 12 — Emerson

ing a "Fringe Compensator," which effectively limits the amplitude of the noise pulses into the sync separator (*V-12A*, 12AU7) to that of the sync pulses, thus minimizing the effects. This fringe compensator should be connected to the set only when it is obvious that it will be beneficial in a certain locality; it should not be installed in strong-signal areas as vertical jitter or audio buzz may result.

Proceed as follows:

1. Locate terminal board on top of chassis in front of power transformer.

2. Clip jumper wire as shown in part (A) of figure.

3. Add part No. 505024 as shown in part (B), making sure yellow dots are lined up and leads are properly soldered.

EMERSON Chassis 120158-B
Preventing jitter in fringe areas
 (see Fig. 13).

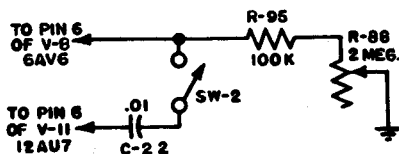

Fig. 13 — Emerson

An adjustable type "Fringe Compensator" may be installed where there is a great deal of electrical impulse noise which tends to cause the picture to jitter or to fall out of sync continuously. The advantage of the adjustable type over the fixed fringe compensator described under "Preventing jitter in fringe areas" for Chassis 120153-B (see above) is that it can be turned off when the receiver is used in strong-signal areas and adjusted for best picture performance in electrically noisy fringe areas.

The circuit and part values are shown in the figure. The connections to *V-8*, to *V-11*, and to ground are conveniently made on a 3-lug terminal strip mounted on the chassis. Be sure to clip the grounding jumper on this terminal strip before connecting this circuit. To adjust the fringe compensator, proceed as follows:

1. Tune set to a low-frequency channel in the normal fashion; if low channels are not available use a higher channel.

2. Turn fringe-compensator switch (SW-2) to the ON position and adjust the potentiometer (R-88) to the center of its mechanical range.

3. Check all channels normally received in the area and re-adjust compensator if necessary for best performance.

Sets coded Triangle B already have this circuit.



FADA

Models R-1025,
R-1050

Extreme fringe-area reception
(see Fig. 14).

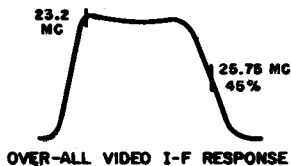

Fig. 14 — Fada

Reception in extreme fringe-area locations poses special installation problems, including the use of high-gain antenna arrays and towers, boosters, etc. Since reception in these areas is accompanied by considerable picture noise or snow, the question of picture quality becomes less important than that of maximum possible gain. For such installations, improved performance can often be realized by realigning the receiver to narrow its picture i-f bandwidth, resulting in greater gain. While this of course decreases the picture de-

finition, the loss cannot be detected in extreme fringe area operation.

The picture i-f strip should be realigned as follows:

1. Replace R-122, 10,000-ohm resistor in grid circuit of 1st picture i-f amplifier (6AG5) with 22,000-ohm, 1/2-watt carbon resistor.

2. Replace R-130, 2,700-ohm resistor in plate circuit of 3rd picture i-f amplifier (6AG5) with 4,700-ohm, 1/2-watt carbon resistor.

3. Realign the picture i-f stages as outlined in the service notes, but obtain the response curve shown in the figure. It will be noted that this is approximately 1 mc narrower than the original ideal curve, which results in increased gain.

FADA

Models S-1055,
S6T65, S7C20, S7C30,
S7T65, S20C10, S20T20

Removing retrace line (see Fig. 15).

To eliminate retrace lines the following circuit changes are necessary:

1. Disconnect screen (pin 10) of picture tube from junction of C-57 and C-58, and reconnect to junction of

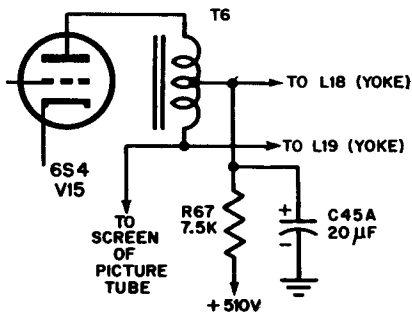

Fig. 15 — Fada

L-19 of the yoke and the B+ terminal of *T-6*.

2. Reconnect the B+ input to the vertical-output stage, to the tap on *T-6* as shown in the figure.

FADA Models S-1055,
S6T65, S7C20, S7C30,
S7T65, S20C10, S20T20

Erratic sync.

If both the vertical and horizontal synchronization are erratic in the presence of noise, disconnect *R-12* from pin 2 of *V-7B* and connect to the junction of *L-11* and *R-16* (in the plate circuit of the video detector.)

FADA Models S-1055,
S-1055X, S-1060

Corona or arcing in h-v cage
(see Fig. 16).

When arcing or corona occurs between the 1B3 tube socket and chassis the following precautions and changes should be followed.

Remove the 1B3 socket assembly from the chassis by removing the two screws that mount the socket assembly on the chassis. Remove the 1B3 tube from its socket and turn the socket over. The socket should be checked for lint, spider webs, and sharp wire or solder points.

Place the plastic insulator strip on the chassis with the long end toward the h-v cage as shown on the sketch. When the socket assembly is remounted, care should be taken that the filament link and leads are kept as far away as possible from the main coil of the horizontal-output transformer, since otherwise corona may result between these two points.

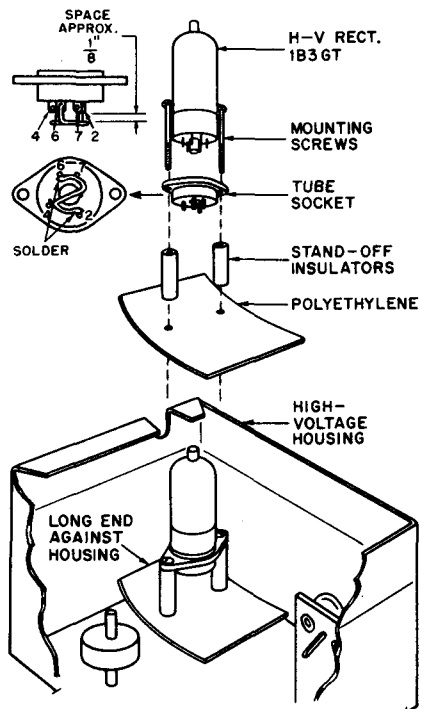

Fig. 16 - Fada

In areas of high humidity an additional change may be necessary if corona still exists under the 1B3 socket. The one megohm resistor mounted on the socket should be replaced with an S-shaped corona ring, constructed of heavy solid wire. The corona ring should be mounted so that all the lugs of the socket are in line with the corona ring, as shown on the attached sketch. In most cases the corona ring will not be necessary; it should be used only when required.

Replace the 1B3 tube and check the leads on the horizontal-output transformer to make sure that their positions have not been changed and that they are not crossing or too close to each other. All of the above

changes and checks can be made with the h-v cage in place.

The modifications described are included in current production of these models to eliminate any possibility of h-v arcing.



FIRESTONE Models 13-G-44
through -48, 13-G-51, -52
Reduction of intercarrier buzz
(see Fig. 17).

Slight dynamic unbalance of the discriminator secondary can emphasize intercarrier buzz due to incomplete amplitude modulation rejection. Therefore it is vitally important to obtain an accurate setting of the discriminator secondary slug under actual reception conditions.

Connect an antenna to the receiver to obtain program reception

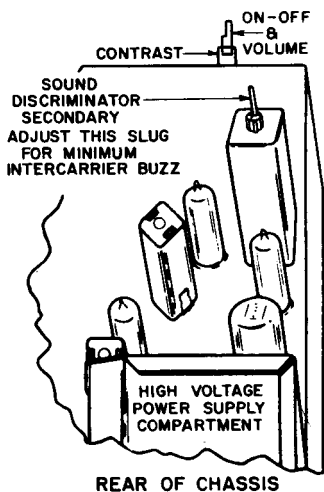

Fig. 17 — Firestone

from a local station. If intercarrier buzz is prominent, a slight readjustment of the discriminator secondary slug should be made to obtain the dip point for the buzzing sound. Note that program sound will be clear and free from distortion at this point. Buzz should now be at an acceptable minimum if station transmission is not at fault.

FIRESTONE Models 13-G-44
through -48
Improving sync stability.

This change is incorporated in the chassis to improve vertical and horizontal sync stability.

1. Resistor 351 (1,800 ohms) is added in plate circuit of V-17B (12AU7), phase splitter. The junction of resistor 246 (1,800 ohms) and capacitor 247 (1,000 $\mu\mu\text{f}$) was formerly connected directly to pin 6 of this tube.

2. Resistor 258 in plate circuit of V-19 (6SN7GT), horizontal scanning multivibrator stage, is changed from 5,600 ohms to 3,900 ohms.

3. Fuse 343 (1 amp), 250 volts is added between red and yellow leads of power transformer 291 and chassis ground.

Models coded Series D already have this modification.

FIRESTONE Models 13-G-44
through -48
**Reducing tube-noise level and
improving picture quality.**

This change is incorporated to decrease tube-noise level and improve picture quality.

1. Resistor 161 in the cathode circuit of V-7 (6AU6), 1st i-f amplifier, is changed from 82 ohms to 270 ohms.

2. Resistor 176 in grid circuit of V-9 (6AU6), 3rd i-f amplifier stage, is changed from 4,700 ohms to 8,200 ohms.

3. Resistor 183 in plate circuit of V-9 (6AU6), 3rd i-f amplifier stage, is changed from 8,200 ohms to 6,800 ohms.

4. Resistor 196 in plate circuit of V-11A (6AL5), detector stage, is changed from 6,800 ohms to 4,700 ohms.

In addition the alignment frequency of the converter-plate coil and 2nd i-f coil is changed from 26.3 mc to 26.1 mc. Voltage measured at certain tube socket terminals on a chassis which includes the above changes will differ from those shown on the voltage chart. New measurements are as follows:

Pin 7 of V-7 (6AU6) 1.5 volts

Pin 1 of V-9 (6AU6) .4 volts

Models coded Series E already have this change.

FIRESTONE Models 13-G-46 through -48

Reducing sweep ringing.

In order to reduce the ringing effect of the horizontal-sweep transformer and deflection yoke, which appears as white (or black) vertical lines on left side of picture screen, the following change is undertaken:

1. Trap coil 354 (part No. 509,615) is added in series with the yoke lead, just before its junction with terminal 5 on the horizontal-output transformer.

2. Capacitor 355 (.003 μ f) is placed in shunt across coil 354.

3. Resistor 356 (680 ohms) is placed in shunt across coil 354.

Models coded Series F already have the above change.

FIRESTONE Models 13-G-46 through -48

High-voltage failure.

Several cases of high-voltage failure have been encountered which were caused by an open 6CD6 cathode bypass capacitor C-269 (5- μ f electrolytic). It is feasible that, not knowing this, a serviceman may make the mistake of changing a perfectly good horizontal-output transformer in his efforts to cure the trouble. Therefore, it is suggested that this be checked before deciding to change any other associated component.

A quick method of checking for a defect in this capacitor is to momentarily ground the cathode of the 6CD6 tube and if, by doing this, the high-voltage output is restored, it is a definite indication that the capacitor is defective and should be replaced.

FIRESTONE Models 13-G-46, -47

Limiting picture-tube beam current.

The following change is made to limit picture tube beam current. Connection to pin 10 of tube V-15 (16TP4 or 16RP4), picture tube, is changed from the 415 B+ boost voltage buss to the 340 B+ buss. Models coded Series F already incorporate this change.

FIRESTONE Model 13-G-48

Improving over-all response curve on all channels.

This change is incorporated to eliminate possible component resonance in the i-f frequency range and to provide a more uniform over-all response curve on all channels. Capacitor 309 in filament-supply cir-

cuit of the r-f tuner is changed from 220 $\mu\mu\text{f}$ to 1,000 $\mu\mu\text{f}$. Models coded Series H already have this change.

FIRESTONE Models 13-G-49,
-50, -53, -54, -55, -59, -79
Horizontal instability.

To reduce horizontal instability, change C-41 (connected to pin 2 of the horizontal-sweep oscillator) from .1 μf to .05 μf . If this change does not correct the trouble, C-41 should be restored to its original value of .1 μf and the following changes made:

1. Change R-57 (connected to pin 1 of the horizontal-sweep oscillator) from 3,900 ohms to 5,600 ohms.
2. Change R-58 (cathode resistor of horizontal-sweep oscillator) from 2,700 ohms to 1,800 ohms.
3. Change R-60 (connected to pin 6 of horizontal-sweep oscillator) from 270,000 ohms to 220,000 ohms.
4. Change R-69 (plate-load resistor of 1st video amplifier) from 2,200 ohms to 3,300 ohms.
5. Change C-58 (cathode bypass capacitor in 2nd video amplifier) from 390 $\mu\mu\text{f}$ to 180 $\mu\mu\text{f}$.
6. Change R-52 (connected to terminal 6 of the horizontal-output transformer) from 2,700 ohms to 5,600 ohms.

Later production runs of most of the above models already include the above changes.

FIRESTONE Models 13-G-49,
-50, -53, -54, -55, -59, -79
Vertical instability.

To reduce vertical instability, proceed as follows:

1. Insert .002- μf capacitor between R-38 (22,000-ohm resistor in in-

tegrating network) and the plate (pin1) of V-13.

2. Remove 3,900-ohm resistor connected from the junction of R-38 and R-39 to ground.

Note: The above changes apply only to the early production runs of models 13-G-49 and 13-G-50. The following changes apply to these and to all other models listed above.

3. Add a 27,000-ohm resistor from pin 1 to pin 3 of V-13.
4. Change R-36 (connected to pin 3 of V-13) from 2,700 ohms to 3,300 ohms.
5. Change R-37 (originally connected to pin 1 of V-13) from 3,900 ohms to 8,200 ohms.

FIRESTONE Models 13-G-49,
-50, -53, -54, -59, -79
Arcing at h-v anode of picture tube.

To correct arcing at the high-voltage anode of the picture tube due to high humidity, proceed as follows:

1. Remove the suction cup, cutting it off from the anode connector or sliding it back. Remove any adhesive tape, if used.
2. Wash the clear glass area around the anode connector with soap and water, then clean with carbon tetrachloride. Re-insert anode connector into picture tube.
3. Spray the area around the anode connector with clear Krylon or some other comparable preparation.

FIRESTONE Models 13-G-51, -52
Increasing range of brightness control.

The following changes are incorporated to reduce the illumination

of picture tubes with minimum setting of the brightness control.

1. Resistor 140 (15,000 ohms) is removed from end of brightness control and chassis ground.

2. Resistor 137 in brightness circuit is changed from 47,000 ohms to 15,000 ohms.

These changes are already included in models coded Series B.

FIRESTONE Models 13-G-51, -52
Improved a-m rejection.

The following changes are incorporated to provide for a new tv sound discriminator transformer which improves a-m rejection.

1. Sound-discriminator transformer 20 is changed from No. 507321 to 509706. Terminal connections are the same for both transformers.

2. Capacitor 18 ($8 \mu\mu\text{f}$) is removed. It formerly was wired externally from pin 1 to pin 2 of the original sound-discriminator transformer 20.

3. Capacitor 20B ($10 \mu\mu\text{f}$) is added. It is an integral part of original sound-discriminator transformer 20, and replaces capacitor 8, removed in step 2.

4. Capacitor 20A across secondary of sound-discriminator transformer 20 is changed from $110 \mu\mu\text{f}$ to $95 \mu\mu\text{f}$.

5. Capacitor 35 in plate circuit of tube V-2 (sound discriminator) is changed from $4 \mu\text{f}$ to $10 \mu\text{f}$.

Models coded Series A already incorporate the above modifications.

FIRESTONE Models 13-G-51, -52
Improving operation of horizontal
multivibrator and increasing
fuse life.

The following changes are incorporated to improve operation of horizontal multivibrator and to reduce

the possibility of fuse 191 blowing out during the warm-up period.

1. Capacitor 174 in plate circuit of tube V-14 (horizontal scanning multivibrator) is changed from $470 \mu\mu\text{f}$ to $390 \mu\mu\text{f}$.

2. Resistor 177 in plate circuit of tube V-14 is changed from 330,000 ohms to 680,000 ohms.

3. Resistor 235 in plate circuit of tube V-14 is changed from 3,900 ohms to 3,300 ohms.

4. Resistor 248 (270,000 ohms) is added between pin 5 of tube V-14 and 315-volts supply.

Models coded Series B already include these changes.

FIRESTONE Models 13-G-51, -52
Centering range of vertical-hold
control.

The following change is incorporated to allow the vertical-hold control to operate in the center of its range. Resistor 223 in grid circuit of V-19A (vertical blocking oscillator) is changed from 1.8 megs to 2 megs. Models coded Series B already have this change.

FIRESTONE Models using
Hytron picture tubes
Poor grounding of aquadag
coating.

When subjected to high humidity, the chalky substance which forms on the aquadag coating of Hytron picture tubes causes poor contact to the ground contact spring. This may result in excessive sync buzz and/or high voltage arc-over at the ground-contact point. To remedy, wash off chalky substance with a damp cloth, dry thoroughly, and apply soft-lead pencil to the area around the ground-contact point.



FREED Chassis 1610,
1620 series, 1916

Centering range of vertical-hold control.

If the frame-lock (vertical-hold) control does not produce proper sync even at the end of its range, replace the 1-meg series resistor (*R-164*). Alternatively, shunt this resistor with a 4.7-meg or 3.3-meg, $\frac{1}{2}$ -watt resistor or replace with a 910,000 ohm resistor.

FREED Chassis 1610,
1620 series, 1916

Centering range of focus control.

To center the range of the focus control, adjust the position of the focus coil either forward or back on the neck of the picture tube, or change the 6V6 (*V-108*), audio-output tube. An alternative is to add an additional bleeder of 10,000 ohms at 20 watts from the 275-volt B+ point to ground if this is not already installed.

FREED Chassis 1610,
1620 series, 1916

Slow drifting horizontal sync.

In the event of slow drifting horizontal sync, change the 6AC7 (*V-124*) and the 6AL5 (*V-123*). If drift is still noticeable, shunt *C-158* ($.015\text{-}\mu\text{f}$ capacitor in 6AC7 circuit) with a ceramic capacitor of about 1,000 to 1,500 $\mu\mu\text{f}$, if this has not already been done.

FREED Chassis 1610,
1620 series, 1916

Sixty-cycle hum at high-volume level.

If 60-cycle hum is encountered at high-volume levels, proceed as follows:

1. Replace 6T8 audio tube.
2. Ground pin 6 of 6T8 (*V-107*).
3. Move a-c switch leads and pilot-light leads well away from audio volume control terminals.

FREED Chassis 1610,
1620 series, 1916

Sixty-cycle hum at low-volume level.

If 60-cycle hum occurs at low-volume levels, proceed as follows:

1. Remove 25- μf capacitor and green lead from minus 2-volt terminal on bleeder. Insert 1,000-ohm, $\frac{1}{2}$ -watt resistor in series between the bleeder terminal and the capacitor and bias wire.
2. Lift B+ end of the 270-k plate-load resistor of the 6T8 audio tube (*V-107*). Place a 47-k, $\frac{1}{2}$ -w resistor from B+ to the loose end of the plate-load resistor. Place a $.1\text{-}\mu\text{f}$, 400-volt capacitor from the intersection of these two resistors to ground.

FREED Chassis 1610,
1620 series, 1916

Sync buzz in sound.

Occasionally, video hash has been found to be radiated from the .05 capacitor that goes from pin 4 of the 6SK7 first sync amplifier (*V-118*). Disconnect the leads going to the terminal strip that supports this capacitor. Reroute this capacitor and the green lead going to it, so that it is well away from the audio circuits.

FREEDChassis 1610,
1620 series, 1916**Vertical buzz.**

If vertical buzz occurs, proceed as follows:

1. Move unshielded hot ends of audio cables away from the cable harness both at the 6T8 audio tube end and at the radio-phonograph switch.

2. The vertical oscillator transformer laminations may be mechanically vibrating. This noise may be removed by crimping the lamination strap with a large pliers.

FREEDChassis 1610,
1620 series, 1916**Tunable hum in strong-signal areas.**

If tunable hum occurs in very strong-signal areas and is not removed by f-m alignment or by the use of an attenuating stub, place an 80- μ f, 150-volt electrolytic capacitor from the tuner B+ terminal to ground.

FREEDChassis 1610,
1620 series, 1916**Internal arcing.**

Internal arcing may be caused by the high-voltage capacitor in the flyback compartment breaking down internally. When replacing this capacitor solder quickly or excessive soldering heat may cause premature component failure.

FREED

Chassis 1610

Vertical buzz or hum.

1. The green wire from pin 5 on the cable socket in the sync chassis that goes to the frame-lock control

should be replaced with a shielded wire grounded at both ends.

2. All audio shielding should be extended so that critical audio leads do not have more than $\frac{1}{4}$ inch exposed. All shielded wire should be bonded to chassis at ends of cable (especially near the 6T8 audio tube).

FREED

Chassis 1610

Picture pulling.

Picture pulling is caused by either a hum pick-up in the agc buss or from a leaky 6T8 agc tube. If replacing 6T8 agc tube does not remove the trouble, place a .5- μ f paper capacitor from the agc buss to chassis.

FREED

Chassis 1610

Arcing and corona accompanied by poor high-voltage regulation.

If arcing and corona occur accompanied by poor high-voltage regulation, replace the 2-meg resistor in the high-voltage compartment with four 500k-ohm, $\frac{1}{2}$ -watt resistors in series.

FREED

Chassis 1610

Centering range of focus control.

If proper focus is produced only at the extreme end of the range of the focus control, proceed as follows:

1. Replace 6V6 audio-output tube.
2. Install a 2,200-ohm, 2-watt resistor in place of the 910-ohm, 2-watt resistor that is in series with the focus potentiometer.

3. Replace the 6,000-ohm, 10-watt bleeder resistor mounted on front part of band switch with a 3,500-ohm, 10-watt resistor.

FREED Chassis 1610
Intermittent video.

Some earlier lots of germanium crystals showed a tendency toward erratic conductivity. Lightly tapping this crystal while observing the picture will make this cause of intermittent operation obvious. If such a condition is found, the crystal should be replaced.

FREED Chassis 1610
Sound bars in picture.

If sound bars appears in the picture, change grid bias on audio-output tube from fixed bias to self bias. This is done by disconnecting R-229 from the grid of the audio-output tube and by inserting a cathode-bias network between the cathode of this tube and ground. The network consists of a 330-ohm, 1-watt resistor which is shunted by a 25- μ f, 50 volt electrolytic capacitor.

FREED Chassis 1620 series, 1916

Corona hiss.

Corona hiss may be caused by leakage of the dust-seal tape where it crosses the picture-tube mounting ring. Corona may also be produced at the socket of the 1B3. The lock washers should be removed from under the screws on the 1B3 (V-127) socket. Dress the pins of the socket.

FREED Chassis 1620A, B, C
Bending or weaving in picture.

In order to eliminate bend or weaving in the picture, proceed as follows:

1. Insert another .004- μ f capacitor across the present one (C-156) con-

nected to one cathode of the horizontal-sync discriminator (pin 1 of V-123, 6AL5).

2. Change capacitor C-157, connected from C-156 to ground, from .05 μ f to .1 μ f.

3. In the 1620 chassis not using keyed agc, connect a 4- μ f capacitor from the agc buss to ground (pin 3 of 6T8).

FREED Chassis 1620A, B
Improvement of sensitivity.

1. The sensitivity can be greatly increased by removing the agc voltage from the tuner. This can easily be accomplished by disconnecting the front-end agc lead from the circuit and grounding the lead. Further gain in sensitivity can be obtained by changing the 6AG5 tube in the tuner to a 6BG5.

2. Change the 5Y3 to a 5V4 tube and realign the set. If oscillation is noticed do not make this change.

FREED Chassis 1620B, C
Sound bars in picture.

If sound bars appear in the picture at high volume levels, if the bars can be varied by manipulation of the volume control, replacement of the vertical-output tube (V-122, 6S4) may remedy the condition. This symptom occurs if the 6S4 is microphonic.

FREED Chassis 1620B
Reduced horizontal sweep.

If a less-than-normal horizontal sweep occurs, proceed as follows:

1. Check pins of the deflection-yoke plug for partial shorts or carbonization. Leakage paths will absorb sweep energy and shorten the sweep.

2. Increase the value of C-229 (across the width coil) with about a 500- $\mu\mu\text{f}$, 1,000-volt capacitor connected in shunt.

FREED Chassis 1620B
Critical fine tuning accompanied by sound bars.

If the fine-tuning adjustment is very critical and there are sound bars present, modify the agc circuit as follows: Move the tuner agc lead, R-135 and C-134 from the intersection of R-136 and R-137, and connect these items to the plate (pin 9) of the 6T8 agc tube.

FREED Chassis 1620B
Wiggle in vertical wedges of test pattern.

If there is wiggle in the vertical wedges of the test pattern, proceed as follows:

1. Install attenuator pad between antenna and receiver.
2. Replace 6T8 agc amplifier and 6AL5 agc detector.
3. Make agc change as noted under "Critical fine tuning accompanied by sound bars."
4. Place a 4- μf capacitor from agc buss to ground.
5. Connect R-171 (vertical-linearity control) to ground instead of to minus 120 volts. Also connect R-230 (vertical output grid resistor) to ground instead of to minus 120 volts.

FREED Chassis 1620B
Linearity changes with changes in brightness or contrast.

Incorrect setting of the horizontal-linearity control may cause the picture to change in linearity with

different settings of brightness or contrast controls. Screw horizontal-linearity control all the way out (counterclockwise), then turn this slug in until first linear picture is obtained.

FREED Chassis 1620B
Noisy or intermittent tuner.

If a noisy or intermittent tuner is encountered, proceed as follows:

1. Clean tuner contact points with carbon tetrachloride or other suitable cleaning fluid.
2. Replace tuner tubes (6AG5, 6J6).
3. Install tuner bearing support (part No. AA-308).
4. Replace tuner.

FREED Chassis 1620C,
1900, 1916
Improvement of sensitivity.

If desired, sensitivity can be increased by reducing the agc voltage. To accomplish this, shunt the 4.7-meg resistor (R-145 or R-209) in the agc network with another 4.7-meg resistor. This component may be located by its direct electrical connection to pin 6 of the sound discriminator, V-107A or V-117A, 6T8.

If the change results in a sync buzz, the indication is that the signal has been made too strong. In this case, the value of the shunting resistor should be changed to 10 meg.

FREED Chassis 1620C, 1900
Improvement of horizontal sync.

If a phasing ghost appears at one side of the picture and the horizontal hold is critical, proceed as follows:

1. Check the following tubes in the horizontal-deflection circuit:

a. Horizontal-sync discriminator, *V-123*, 6AL5.

b. Horizontal-oscillator control, *V-124*, 6AC7.

c. Horizontal-oscillator, *V-125*, 6K6.

2. Resistor *R-172* in the 1900 chassis or *R-186* in the 1620C chassis, located at the plate of the horizontal oscillator (pin 3 of *V-124* or *V-125*, 6K6) is changed from 5 k to 7 k, 10 watts.

3. Capacitor *C-154* in the 1900 chassis or *C-161* in the 1620C chassis, connected to the screen of the horizontal-oscillator control (pin 6 of *V-123* or *V-124*, 6AC7), is changed from .05 μ f to .02 μ f.

4. For best performance readjust all front- and rear-panel controls that are allied with the horizontal circuit. These include all oscillator, linearity, width, focus, and phasing controls.

5. If critical horizontal-hold action persists after the above changes have been made, check the voltage on that cathode of the horizontal-sync discriminator which is tied to the -2 volt source (pin 5 of *V-122* or *V-123*, 6AL5). If the reading is less than -2 volts check the -2 volt source in the power supply for changes in resistor values.

FREED Chassis 1620C, 1900
Reduction of audible sync buzz.

A loud 60-cycle buzz, originating in the vertical-oscillator stage, sometimes occurs. To reduce, proceed as follows:

1. Obtain a .03- μ f, 400-volt capacitor.

2. Connect one end of the capacitor to the plate of the vertical oscillator (pin 2 of *V-121*, 6SN7, in 1620C

chassis; pin 3 of *V-120*, 6J5, in 1900 chassis).

3. Connect the other end of the capacitor to ground.

4. If necessary, readjust the vertical-linearity and size controls.

FREED Chassis 1900
Focus improvement.

If good focus cannot be obtained by ordinary adjustment of the focus control, proceed as follows:

1. Locate the 2,200-ohm resistor (*R-190*) connected between the focus control (*R-189*) and ground.

2. Shunt it with a 1,500-ohm, 2-watt resistor.

3. Readjust the focus control.

FREED Chassis 1916
Horizontal shake.

To eliminate horizontal shake, proceed as follows:

1. Check adjustment of the horizontal-phasing and horizontal-sync controls.

2. Change *R-172* (in plate circuit of horizontal oscillator) from 2,500 ohms to 5,000 ohms.

3. Change *R-193* (in cathode circuit of horizontal-oscillator control tube) from 100 ohms to 10 ohms.

FREED Chassis with metal picture tubes
Neck shadow and poor centering.

The presence of neck shadow and difficulty in centering may be due to a magnetized picture tube. Rotate tube about 180 degrees. If neck shadow is quite critical, remove the two rubber bumpers on the yoke assembly and force the yoke closer to the picture tube. Recenter the picture.

FREED

Chassis with
metal picture tubes

**Distortion due to magnetized
picture tube.**

If a strong magnetic field is brought near the picture tube, the metal cone can be sufficiently magnetized to cause objectionable distortion in the image. The principal indication of distortion is a kink in the edge of the raster. The most likely cause of cone magnetization is contact of the metal with the frame of a permanent-magnet loudspeaker. Magnetized sections near the middle and small end of the cone produce the most disturbance. The magnetism, however, is usually localized and can readily be detected with a pocket compass.

In the event the cone should become magnetized, it can easily be demagnetized by the use of the a-c magnetic field produced by a simple coil. A suitable coil consists of approximately 1,250 turns of No. 24 copper wire wound on a diameter of 7 inches and protected by an insulating covering. Because this coil takes about 1 ampere at 117 volts and will overheat on continuous duty, it should be used only intermittently. To demagnetize the metal cone, energize the coil and move its flat side over the magnetized area. The coil should not be de-energized until it is moved away from the cone, since the current may not cut off at zero field strength.

FREED

All chassis

Eliminating corona.

Check the lug attachment to the 500- μ f high-voltage capacitor in the 1B3 circuit. Round the points on

the lug with a drop of solder. Sometimes corona disappears simply if the lug is bent. Re-dress the h-v lead. Adjust the horizontal-peaking control.

**GAMBLE-SKOGMO (Coronado)**

Models 05TV1-43-8945A,
-9005A, -9006A

**Eliminating squegging or parasitic
oscillations.**

It is suggested that when an early production model is received for service, or if a squegging condition (parasitic oscillation) is noticed, the following wiring changes be made:

1. Reroute the black a-c leads from the a-c input socket to the switch on the dual contrast and volume control.
 - a. Disconnect the two black a-c leads at the switch terminals.
 - b. Pull out the a-c leads from the side of the chassis and reroute along the tuner side and bring down to the switch.
 - c. Cut off 4 inches from the longer lead and add 18 inches to the shorted lead.
 - d. Reconnect the a-c leads to the switch terminals.
 - e. Make sure the a-c leads do not short to chassis and will not tangle with tuner or cam. It is suggested that a cable clamp be soldered to the tuner side of the chassis to hold the a-c leads in place.

2. Replace resistor R-82 (220 k) in the a-fc feedback loop with a 470k-ohm, 1/2-watt resistor.

GAMBLE-SKOGMO (Coronado)

Model 05TV1-43-9014A

Apparent yoke failures.

Apparent yoke failures evidenced by a reduction in over-all width and a trapazoiding effect (width at bottom less than that at top) may be caused by a defective 47- $\mu\mu\text{f}$ capacitor (C-126) wired internally in the yoke. The 47- $\mu\mu\text{f}$ capacitor (C-126) is of the uninsulated ceramic type and, due to incorrect lead dress, may cause a shorting condition.

Before the yoke is replaced, the 47- $\mu\mu\text{f}$ capacitor should be checked. If the capacitor is shorted it should be replaced and the yoke can again be used.

If this trapazoiding condition is noticed, the yoke can be removed without pulling the chassis from the cabinet. Remove the cabinet back, picture-tube socket, ion trap, focus magnet, wing nut, yoke plug and then the yoke.

GAMBLE-SKOGMO (Coronado)Models 05TV2-43-8950A,
-9010A**Eliminating h-v arcing.**

If arcing occurs between the filament winding of the 1B3, located in the high-voltage box, and the clamping on the high-voltage transformer, remedy as follows:

1. Bend back the soldering lugs on the mounting bracket side of the transformer that are used to clamp the filament winding in place so that they are completely out of contact with the one-turn filament winding.

2. Replace the present red-filament lead and black-fibre glass tubing, if it has broken down, with a new lead and new tubing.

GAMBLE-SKOGMO (Coronado)Models 05TV2-43-8950A
-9010A**Improvement of horizontal stability.**

A slight horizontal movement or waver in the picture may result when the transmitting station sends out weak sync pulses. Correct as follows:

Change resistor R-48, located between the cathode of the sync separator (pin 8 of V-11B, 12AU7) and ground, from 270,000 ohms to 47,000 ohms.

Note: Later production receivers, identified by a green paint mark on the rear of the chassis, incorporate this change.

GAMBLE-SKOGMO (Coronado)Models 05TV2-43-9010B,
15TV2-43-9012A, -9013A**Reducing 1X2 tube failures.**

To reduce 1X2 tube failures, the tube manufacturer recommends the installation of a 50-k (47-k to 68-k), $\frac{1}{2}$ -watt resistor in the plate circuit of the 1X2 tube. This resistor may be installed between the plate lead and the plate cap. All solder connections should be smooth to prevent corona discharge.

GAMBLE-SKOGMO (Coronado)Models 05TV2-43-9010B,
15TV2-43-9012A, -9013A**Improving sensitivity in fringe areas (see Fig. 18).**

To improve the signal-to-noise ratio in fringe areas on the models listed above, the changes in the agc circuit shown in the partial schematics are suggested. Part numbers and descriptions of the parts to be removed and added are listed.

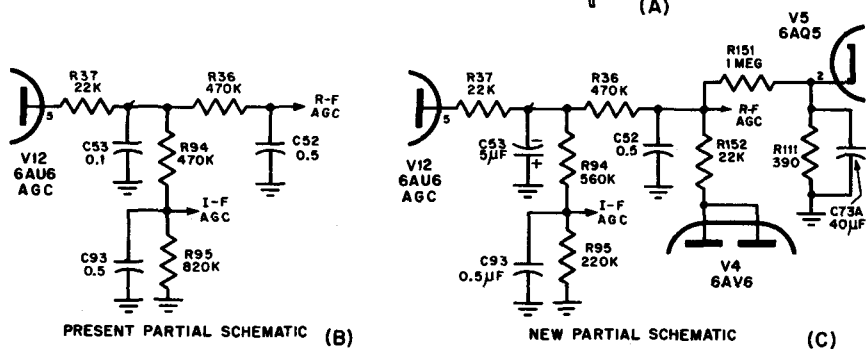
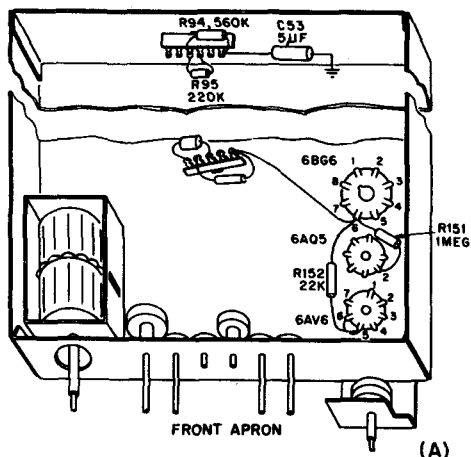

Fig. 18 - Gamble-Skogmo (Coronado)

PARTS LIST

Schematic No. *Part. No.* *Description*

Remove the following:

R-94	B85474	470k-ohms carbon resistor
R-95	B84824	820k-ohms carbon resistor
C-53	B65104	.1- μ f, 200-v tubular capacitor

Add the following:

R-94	B84564	560k-ohms, $\frac{1}{2}$ -watt carbon resistor
R-95	B84224	220k-ohms, $\frac{1}{2}$ -watt carbon resistor
R-151	B84105	1-meg, $\frac{1}{2}$ -watt carbon resistor
R-152	B85223	22k-ohms, $\frac{1}{2}$ -watt carbon resistor
C-53	45X361	5- μ f, 100-v dry electrolytic capacitor

GAMBLE-SKOGMO (Coronado)

Model 94TV1-43-8940A

Horizontal nonlinearity.

If horizontal nonlinearity (left-hand bulge) is noticed in the above models on which the chassis are coded 1 through 15, reverse the leads connected to terminals 2 and 3 of the horizontal-deflection transformer (T-6).



GENERAL ELECTRIC

Models 10C101,
-102, 10T1, -4, -5, -6,
12C107, -108, -109,
12K1, 12T3, -4, -7

Oscillation of horizontal-sweep output stage.

When the receiver operates satisfactorily until the horizontal sync is momentarily disrupted (switching to another channel), but then cannot be brought back into sync by adjustment of either the front or rear panel horizontal-hold controls, it may be the result of oscillation of the horizontal sweep output stage. The set usually may be resynced by turning off the power switch for an instant. This condition is further confirmed by removing the horizontal oscillator tube for an instant, if sweep and hi-voltage still exist the trouble is definitely established.

The above results from a partial voltage breakdown within the 6- μmf capacitor C-330 (C-369) in the grid circuit of the horizontal-output tube. Because of its peculiar construction, the capacitance may rise to over 200 μmf . At this high capacitance value, the horizontal-output stage oscillates and if a sawtooth is supplied to the

grid, the output tube will operate as a controlled oscillator. However, after control is lost it will oscillate at its own frequency, resulting in the trouble described above.

It is recommended that a replacement for this capacitor be made with a voltage rating of 1,500 volts. Use stock No. RCU-300 (6 μmf , 1,500 volts, mica).

GENERAL ELECTRIC

Models 10C101,
-102, 10T1, -4, -5, -6,
12C107, -108, -109,
12K1, 12T3, -4, -7

Failure of audio i-f transformer.

Failure of the 4.5-mc audio i-f transformer in the 10T- and 12T-series of television receivers in areas of high humidity has been due to faulty lead dress inside the transformer shield which permitted the secondary leads to touch the primary winding at the point where these leads pass, prior to their connection to the transformer terminals. Although the leads and winding are insulated, electrolysis takes place under conditions of high humidity, eventually causing a breakdown between the primary winding and secondary lead.

This condition was corrected in production by placing a fiber washer adjacent to the primary winding which prevented the secondary leads from touching the primary. However, some of the replacement RLI-097 transformers may not have this fiber washer incorporated. Therefore it is suggested, when making a replacement, that the shield be removed from the replacement transformer, and the secondary lead dress checked to make certain that these leads do not touch the primary winding.

GENERAL ELECTRIC

Models 10T1,
-4, -5, -6

Centering range of vertical-hold control.

The vertical-hold potentiometer, R-298, is increased in value from 100,000 ohms to 125,000 ohms. The resistance of the horizontal-hold control with which it is combined, remains the same. The new dual potentiometer has stock No. RRC-134. This change is made to better center the adjustment of the vertical-hold control.

GENERAL ELECTRIC

Models 12C107,
-108, -109, 12T3, -4, -7

Improvement of horizontal pull-in range.

To increase the horizontal pull-in range, the resistor R-379, in the biasing network for the horizontal-control tube, V-12A, is changed from a 180,000-ohm to a 270,000-ohm value. The new part No. is URD-107.

GENERAL ELECTRIC

Models 12C107,
-108, -109, 12T3, -4, -7

Audio buzz at low contrast setting.

Early production receivers made use of a 41.25-mc trap coupled to the 2nd video i-f coil. On some receivers this caused buzz in the audio when the receiver was properly tuned for best picture detail at low contrast setting or when operating on a rather weak signal. This trap was removed on all late production receivers and was made less effective on receivers in process of fabrication, by shunting the trap by a 5,100-ohm, 1/2-watt

resistor connected across the trap trimmer C-281. If this change is desired in the field, the shunting of C-281 by the resistor does not require a realignment of the video i-f.

GENERAL ELECTRIC

Models 12C107,
-108, -109, 12T3, -4, -7

Increasing horizontal sweep.

In order to increase horizontal sweep, the following changes are incorporated: a capacitor, C-380, is added across the terminals 6 and 8 of the horizontal-sweep transformer. The type used is a 220- μmf capacitor, 1,500 volts with a part No. of RCU-295. At the same time the wiring of capacitor C-376 is changed to connect to terminal 5 of the damper tube V-15, 25W4GT.

In case a capacitor of 220 μmf , 1,500 volts is not available, use two capacitors of values 390 μmf , (part No. UCU-1042) at 500 volts or 470 μmf (part No. UCU-1044) at 500 volts in series connection.

GENERAL ELECTRIC

Models 12K1, 818

Use of adapter plug for separate chassis servicing (see Fig. 19).

An adapter plug may be made which makes it unnecessary to remove the television chassis when service

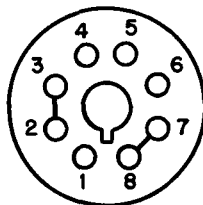

Fig. 19 — General Electric

has to be rendered on the radio chassis only, of models 818 and 12K1. A standard octal tube base is wired as shown in the sketch. A jumper is connected between pins 7 and 8 and also between pins 2 and 3. This plug is then inserted into the *J-4* socket on the radio chassis to re-instate audio continuity and to energize the tube filaments when the radio is separated from the tv chassis. A-c power is furnished at pin 3-4 of *P-3* or with a suitable plug in receptacle *J-2*. *Precaution:* When using the latter point for power connection, it requires a male pin jack which makes the pins hot at 110 volts.

The plug shown may also be used when servicing the television chassis separate from the radio chassis. When this plug is inserted into the octal socket *J-5* on the television chassis, it permits application of power to the television chassis for alignment or troubleshooting purposes.

GENERAL ELECTRIC

Models 12T7, 16C110,
-111, -115, 16T1, -2

Increasing low-frequency response.

To increase the low-frequency response of the video amplifier, the capacitor *C-268* is changed from a .02- μ f to a .05- μ f value. The new number is UCC-045.

GENERAL ELECTRIC

Models 14C series,
14T series, 16C series, 16K
series, 16T series, 17C series,
17T series

High-channel trap adjustment.

These receivers incorporate a trap (*C-206*, *L-203*) on the head-end unit which is switched into the antenna circuit on all low-band chan-

nels and will eliminate high-channel interference on these channels. This interference manifests itself as horizontal bars, or herringbone pattern, or as a picture in the background. If the receiver is tuned to channel 5, a strong station operating on channel 11 will beat with the second harmonic of the local oscillator to form an i-f frequency which will ride through unhindered and appear on the picture screen. In order to prevent the interfering signal from reaching the converter, a trap consisting of a fixed inductance and a variable capacitance is adjusted for maximum rejection of the interfering station. This type of interference is also possible on channels 4 and 6, due to interfering stations on channel 8 and 13 respectively. The trap is adjusted at the factory, approximately for channel 11 rejection. It may be necessary to readjust the trap slightly for maximum rejection of channel 11.

The adjustment of the trap can be made by means of a signal generator and an oscilloscope or an a-c meter as indicating device. The signal generator must be terminated to match 300 ohms impedance. For elimination of channel 8, 11 or 13 interference, feed a strong signal of the picture carrier of the interfering station modulated with an audio signal into the antenna terminals and connect the indicating device to the picture tube grid. Set the band selector to the channel 4, 5 or 6, respectively, and tune local oscillator of receiver for maximum deflection on indicating device. Then tune trimmer *C-206* for minimum signal on picture-tube grid.

The adjustment of the trap can be made without instruments as follows:

When the channel interference appears in the picture, set the tuning control for maximum interference. Then tune trimmer *C-206* for minimum interference or maximum rejection.

GENERAL ELECTRIC

Models 14C102,
-103, 14T2, -3, 16C103, -104,
-113, -116, 16T3, -4, -5, -6,
17C101, -102

Preventing vertical jitter.

The following circuit change will prevent vertical jitter and result in minor interlace improvement. The circuit change is as follows: Add a 1,000- μmf 1,000-volt mica capacitor (stock No. RCU-290) from pin 1 or pin 6 of the vertical sweep output tube (*V-10*) to the B+ side of capacitor *C-453*. This removes any horizontal sweep frequency components from the vertical-sweep output.

GENERAL ELECTRIC

Models 14C102,
-103, 14T2, -3, 16C103, -104,
-113, -114, 16K1, -2, 16T3,
-4, -5, -6

Forestalling capacitor breakdown under humid conditions.

The capacitors *C-275*, *C-311*, *C-351*, and *C-356* are changed to a molded type or the voltage rating is increased to forestall voltage breakdown or leakage under humid conditions. The nominal capacitance values remain the same.

C-275 is changed to a 600-volt, molded unit (stock RCN-031). This capacitor is the output coupling capacitor in the 2nd video amplifier.

C-311 is changed to 1,000 volt, molded unit (stock RCN-030). This

capacitor is the input capacitor in the vertical blanking tube.

C-351 is changed to 1,000 volt, molded unit (stock RCN-044). This capacitor is the input capacitor to the sync amplifier and clipper.

C-356 is changed to 800 volt, mica unit (stock RCU-299). This capacitor is the output capacitor of the sync amplifier and clipper.

GENERAL ELECTRIC

Models 14C102,
-103, 14T2, -3, 16C103, -104,
-113, -114, 16K1, -2, 16T3,
-4, -5, -6

High leakage of C-311.

In the service notes for the above models, the statement is made that retrace lines become visible when *C-311* is shorted. This capacitor is the coupling capacitor between the vertical-output tube and the vertical-blanking tube. Actually no illumination to the picture-tube screen is possible under this condition. However, this particular capacitor has a rather peculiar effect under high-leakage conditions. First indications of leakage (in the order of several megohms) result in the screen becoming partially blanked at the top of the picture. As the leakage resistance decreases, more and more of the screen blanks out until finally, for leakage values below 1 megohm, all of the picture is blanked out. It may be desirable to record this condition in the applicable service notes in view that a few failures of *C-311* had been reported in the field, in most cases not involving a complete breakdown of the component but showing up as a leakage with characteristics as described above.

GENERAL ELECTRIC

Models 14C102,
-103, 14T2, -3, 16C103, -104,
-113, -114, 16T3, -4, -5, -6

Preventing excessive plate current in horizontal-output tube.

Failure of the sweep generator or a component which results in a loss of drive voltage on the grid of the sweep-output tube, *V-14*, results in excessive plate current in the 25BQ6 tube. In some cases, the tube heats enough to cause the plate cap solder to melt so that it cannot be removed from the 25BQ6 tube. To forestall this condition a 39-ohm resistor (stock URE-015) is added to the cathode circuit as follows: Remove the yellow wire which connects pin 8 of *V-14* to the B- buss. In its place add a 39-ohm, 1-watt resistor (stock URE-015). Dress leads away from resistor so that heat dissipation will not affect adjacent components. This change is incorporated in all later production receivers.

GENERAL ELECTRIC

Models 14C102,
-103, 14T2, -3, 16C103, -104,
-113, -114, 16T3, -4, -5, -6

Curl at top of picture (see Fig. 20).

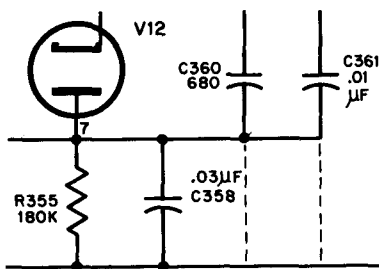

Fig. 20 — General Electric

A few receivers have shown a slight displacement (to the right) of the first few horizontal scan lines which shows up as a slight curl at the top of the picture. This trouble is caused by a delay in recovery of the horizontal afc circuit after the occurrence of each vertical sync pulse, and is compensated for by feeding a correction voltage of proper magnitude and phase into the afc circuit. The circuit revision is shown in the sketch; the procedure follows:

1. Disconnect capacitors *C-360* and *C-361* from B- and reconnect them to the junction of *R-355*, *C-358* and the plate (7) of *V-12*.

2. Change the value of *C-358* from a .02- μ f capacitor to a .03- μ f capacitor (stock No. UCC-042).

GENERAL ELECTRIC

Models 14C102,
-103, 14T2, -3, 16C110, -111,
-113, -115, -116, 16T1, -2,
-3, -4

Abnormal failure of 1X2 filaments.

Abnormal failure of the type 1X2 high-voltage rectifier is due to excessive filament voltage in those receivers which have unusually high efficiency sweep-output transformers when such receivers are operated on high line voltage. In such cases it is recommended that a 1.2-ohm, 1/2-watt resistor be added in series with the type 1X2 tube filament. To reduce the possibility of corona, the following procedure is recommended:

Remove wire from pin 9 of 1X2 socket. Shorten wire 1/2 inch. Connect the 1.2-ohm resistor (RRW-058) to the shortened filament wire, making certain that there are no sharp points of wire or solder exposed. Cover the soldered junction with 1/4

inch h-v spaghetti tubing. Solder the other end of the 1.2-ohm resistor to pin 6 of the type 1X2 socket. Dress the resistor close to the socket.

GENERAL ELECTRIC

Models 14C102,
-103, 14T2, -3, 16C113, -116,
16K1, -2, 16T3, -4

Reduction of channel-4 smear and channel-6 oscillations (see Fig. 21).

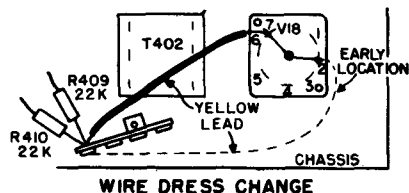

Fig. 21 — General Electric

To reduce channel-4 smear (4.5-mc harmonic interference) and channel-6 oscillations, connect *C-227*, 800- μmf , 350-volt ceramic capacitor (stock RCW-3037) across the isolating gap between receiver chassis and rear edge of head-end chassis. Using as short leads as possible, solder one end of *C-227* to the soldered head-end chassis connection of *C-206* mounting clip. The other lead may be soldered to a lug fastened securely at the punched receiver chassis hole adjacent to the tube socket *V-21*.

Remove *C-252*, 5,000- μmf ceramic capacitor from the seventh hole of the resistor-capacitor terminal board B— buss and the chassis weld between the sockets *V-5* and *V-6*. Relocate *C-252* to a point between the front end of the terminal board and *L-251*. Using a short lead, connect one end of the capacitor to the first B— buss hole of the terminal board. For best

soldering convenience and shortest capacitor lead length, pass remaining lead through the 3/8 inch chassis hole nearest *L-251* and solder the lead from top of chassis to a cleaned and tinned top edge of the hole.

The yellow lead that formerly connected from pin 2 of *V-18* is removed from this point on the tube socket, and shortened to connect directly to pin 7. All leads which run past the terminal board illustrated are pushed down against the chassis and dressed as far away as possible from the yellow lead.

GENERAL ELECTRIC

Models 14C102,
-103, 14T2, -3, 16C113,
-116, 16T3, -4

Correcting bending at top of picture (see Fig. 22).

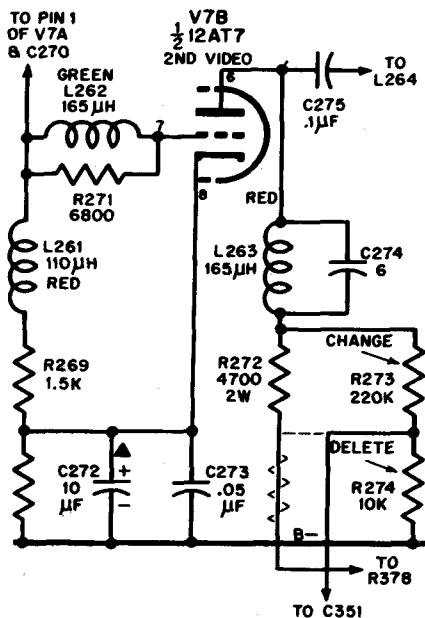

Fig. 22 — General Electric

In early production receivers R-273, R-274 and the sync voltage take-off capacitor C-351 were connected as shown in the figure. To correct bending at the top of the picture R-274 is deleted. R-273 is changed to 220 ohms and is reconnected in series with R-272. C-351, the sync-coupling capacitor, is now connected at the junction of R-272 and R-273 as shown in the dashed lines.

GENERAL ELECTRIC

Model 14C102,
-103, 14T2, -3, 16C113,
-116, 16T3, -4

Eliminating vertical lines at left side of picture.

Capacitor C-371, .05 μ f, 600 volts, is added to later production receivers, to bypass transient voltages developed by the horizontal-sweep circuit at the B+ supply. These voltages would produce the effect of vertical, light and dark bars in the left part of the picture.

The capacitor, C-371, is connected from the B+ terminal of the terminal strip adjacent to the damper tube, V-16, on the chassis side apron and to the B- buss connection of C-374.

GENERAL ELECTRIC

Models 16C110,
-111, -115, 16T1, -2

Improving vertical stability.

To eliminate vertical bounce of the picture (vertical shift) at certain settings of the picture control which may be noted when a change in studio cameras takes place, change the plate-coupling circuit of V-11 as follows. R-353 is changed to 470,000 ohms and C-353 is changed to 470 μ f. Late production models incorporate this change.

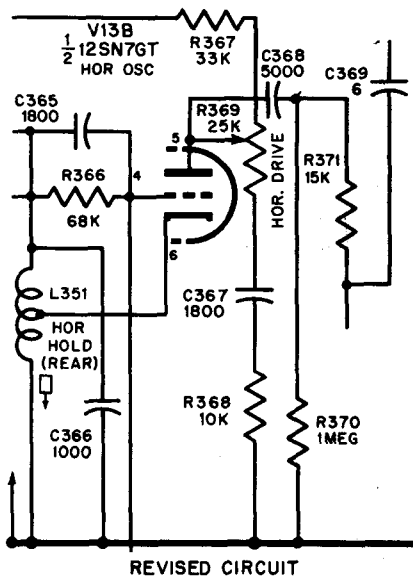
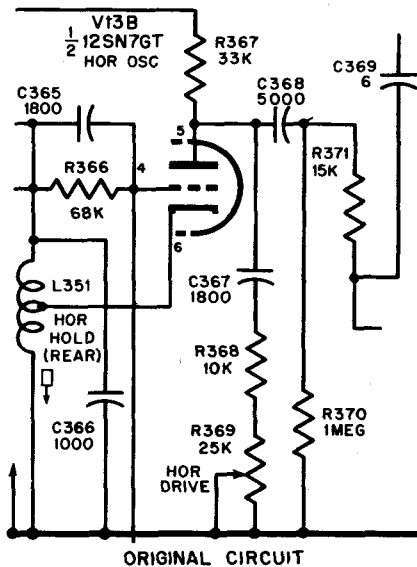

Fig. 23 - General Electric

GENERAL ELECTRIC

Models 16C110,
-111, -115, 16T1, -2

Drive-control setting affects horizontal pull-in sensitivity (see Fig. 23).

The horizontal-drive control R-369 is reconnected to remove the effect of the drive-control setting on the horizontal pull-in sensitivity.

If any early production receivers are rewired as shown in the schematic diagram, potentiometer R-369 should be changed to one of higher wattage rating. Catalog number for the higher wattage rating R-369, 25-k potentiometer, is RRC-140.

GENERAL ELECTRIC

Models 16C110,
-111, -115, 16T1, -2

Eliminating Barkhausen oscillation.

To eliminate Barkhausen oscillation (vertical black beady lines in raster when not receiving a station) the following resistor is added to early production receivers.

Pin 8 of V-14 is connected to B— through a 47-ohm, 1-watt resistor, cat. No. URE-017.

GENERAL ELECTRIC

Models 16C110,
-111, -115, 16T1, -2

Eliminating yoke ringing.

Capacitor C-378, connected across the horizontal-deflection coil D-351, is changed from 56 $\mu\mu\text{f}$ to 47 $\mu\mu\text{f}$. This change is made to reduce the possibility of vertical light bars appearing on the left side of the raster. The new capacitor, which is a 1,500-volt mica unit, is stock No. RCN-037.

GENERAL ELECTRIC

Models 16K1, -2
Reducing residual hum
(see Fig. 24).

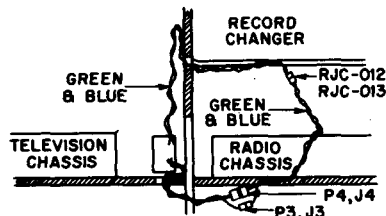

Fig. 24 — General Electric

On the above models where hum modulation (tunable hum) on the broadcast band or a residual hum on broadcast, tv, and phono is experienced, the following circuit changes should be made to correct the condition. (Step 1 is made only where tunable hum is encountered, while steps 2, 3, and 4 are made to reduce residual hum.)

1. A .022- μf , 600-volt capacitor (stock RCN-050) is added from the (black) primary lead of the power transformer to ground.

2. A 20- μf , 450-volt capacitor (stock RCE-093) is connected across the capacitor section C-39A of the radio chassis.

3. The inter-cabling of the radio and television receiver chassis is changed as follows: The audio blue and green coded wires that connect through pins 3 and 2 of the plug P-4 and socket J-4 are removed from the connector. These two leads are connected together through a new 2-pin connector (RJC-012 and RJC-013) and are dressed as shown in the illustration.

4. With this cable reconnection, a 22- μmf capacitor (stock UCU-012) is connected from the high side of the volume control, *R-18*, to ground at the tone-control switch.

Later production models already include this change.

GENERAL ELECTRIC

Models 17C110, -111

Improved sync-circuit operation.

Late production receivers had some changes in the wiring of the horizontal-sync circuit. Due to capacitance effects of the various wires and the high voltage of this circuit, the sync circuit did not operate properly at normal contrast control setting. To eliminate this trouble the wiring was later changed. In case some early production receivers show this defect, rewire the set as follows:

1. Change deflection-yoke lead from terminal *C-10* to *R-11*.

2. Change pin connection *C-10* to *R-11*.

3. Change video peaking coil connection from *C-9* and *C-7* to *C-6* and *C-5*.

4. Change lead on *C-6* to *C-7*.

5. Change pin connection on *C-9* to *C-6*.

6. Change pin connection on *C-6* to *C-7*.

7. Change capacitor *C-166* connected to *C-7* to *C-5*.

8. Change resistor *R-174*, 470,000 ohms, connected to *C-7* to *C-5*.

GENERAL ELECTRIC

Models 17C110, -111

Reduced plate dissipation of 3rd video i-f tube.

The plate dissipation of the 3rd video i-f tube, *V-106* (6CB6) is re-

duced by decreasing the resistance *R-181*, 33,000 ohms (in the screen-grid circuit) to a value of 18,000 ohms, part No. URD-079. At the same time it is wired across the capacitor *C-159*.

GENERAL ELECTRIC

Models 17C110, -111

F-M interference reduction in tuner (see Fig. 25).

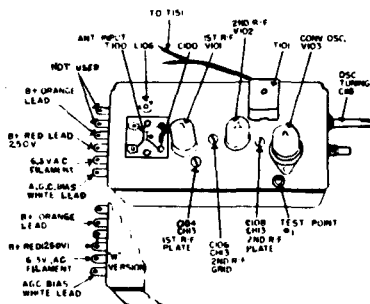

Fig. 25 — General Electric

In order to reduce f-m interference the resistance *R-103*, (3,300 ohms, 1/2 watt) in the tuner is increased to a value of 5,600 ohms, 1 watt, part No. URE-067. The r-f tuner with this new resistor is stamped "W" for easy identification. To compensate for the higher voltage drop the B+ to the tube *V-101* is increased from 160 to 250 volts. This is accomplished by moving the orange wire (B+ 160 volt) to the second lug from the top (see figure) and connecting the third lug with the fourth lug which connects the B+ for *V-102* to the B+ 250-volt red lead.

At the same time the resistance *R-402*, 2,000 ohms, 10 watts, wire-wound, (connected to the B+ output

of the power supply) is changed to a value of 2,350 ohms, part No. RRW-083.

GENERAL ELECTRIC

Models 17C110, -111

Improving vertical linearity.

Resistor *R-306*, 330,000 ohms, 1/2 watt (in the grid circuit of the vertical-output tube) is changed to a value of 820,000 ohms, part No. URD-119, in order to improve the vertical linearity.

GENERAL ELECTRIC

Models 17C110, -111

Removing i-f "tweets."

In order to remove i-f "tweets" a filament choke, *L-165* (RLF-048), is connected between terminal pin *P-4* and filament of tube 6AL5 (*V-110*). Resistor *R-224* and capacitor *C-219* are rewired with the capacitor between secondary of *T-203* and the junction of *R-225* and grid connection (pin 1) of *V-109* and with the resistor *R-224* from this junction to ground. The bottom end of the secondary is connected to ground.

GENERAL ELECTRIC

Models 17C110, -111

Increasing range of brightness control.

In order to increase the range of the brightness control, resistor *R-175* (in series with the control) is changed from 100,000 ohms to a value of 56,000 ohms (URD-091).

GENERAL ELECTRIC

Models 17C110, -111

Improved deflection-yoke installation (see Fig. 26).

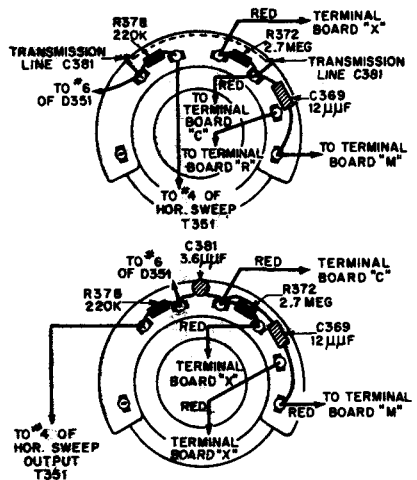

Fig. 26 — General Electric

The early production yoke RLD-030 which is identified by the markings on the yoke as follows "M77J11-10- #33, blue code dot on the winding tape" is replaced by the yoke RLD-037. The use of this improved yoke necessitates the installation of a variable trimmer, *C-302*, RCY-069 (1 to 12 mmf). The trimmer is connected to the yoke terminal 8 and chassis ground. A lead is already provided on the yoke for this purpose.

The trimmer is a single hole mount type and is fastened to the blank hole between two terminal boards directly above the yoke assembly with the trimmer screw facing the back of the receiver. The ground connection is made automatically through the body of the trimmer capacitor.

Care should be exercised in tightening the mounting nut on the trimmer as the trimmer is fragile, and can easily be damaged. A locking nut is provided on the trimmer and should be screwed down against the mounting nut to hold the adjustment.

YOKE

TRANSFORMER

<i>Cat. No.</i>	<i>Stamped on Unit</i>	<i>Cat. No.</i>	<i>Stamped on Unit</i>
EARLY PRODUCTION			
RLD-030	M77J11-10 Blue code dot on winding tape.	RTO-110	K82J183
LATE PRODUCTION			
RLD-037	M77J11-15 Green code dot on winding tape.	RTO-102	K82J183-2

For adjustment of this trimmer see the service notes.

Because of different type deflection coils, it is necessary to use a different vertical-sweep-output transformer with this late type yoke. In order to avoid mistakes when replacing yokes and vertical output transformers, the chart above will be helpful.

On some yokes the capacitor *C-381* (3.6 $\mu\mu\text{f}$) will be a short piece of transmission line instead of the disc-type capacitor. To accommodate these, the terminal board arrangement is slightly different on each yoke. The proper connection for each is shown in the figure.

GENERAL ELECTRIC

Models 17C113,
-115, -117, -120, 17T7

Reduction of hum modulation on horizontal sweep.

To reduce hum modulation on horizontal sweep, the triode sections of tube *V-13*, 12SN7GT are interchanged; no component changes are made. After the interchange, pins 4, 5, and 6 are used as the afc section, while pins 1, 2, and 3 are used as the horizontal-oscillator section.

GENERAL ELECTRIC

Models 17C113,
-115, -117, -120, 17T7

Reduction of channel-6 "tweet" (see Fig. 27).

To reduce channel-6 "tweet," the choke *L-256* is incorporated into the video-detector assembly which carries the new part No. RLX-034. When replacing the old assembly with the new one, it will be necessary to short out the old *L-256* choke.

GENERAL ELECTRIC

Models 17C113,
-115, -117, -120, 17T7

Replacement of video-detector crystal (see Fig. 28).

To facilitate replacement of the video-detector crystal diode, an improved design of the video-detector assembly (RLX-035, marked with a red dot on top of the assembly) is used to provide top mounting of the diode. It is merely necessary to slip off the cover of the assembly to expose the diode.

In some assemblies a special high efficiency diode is used, marked with a red dot. To maintain the same Q of the circuit and to obtain proper i-f bandwidth a resistor of 12,000

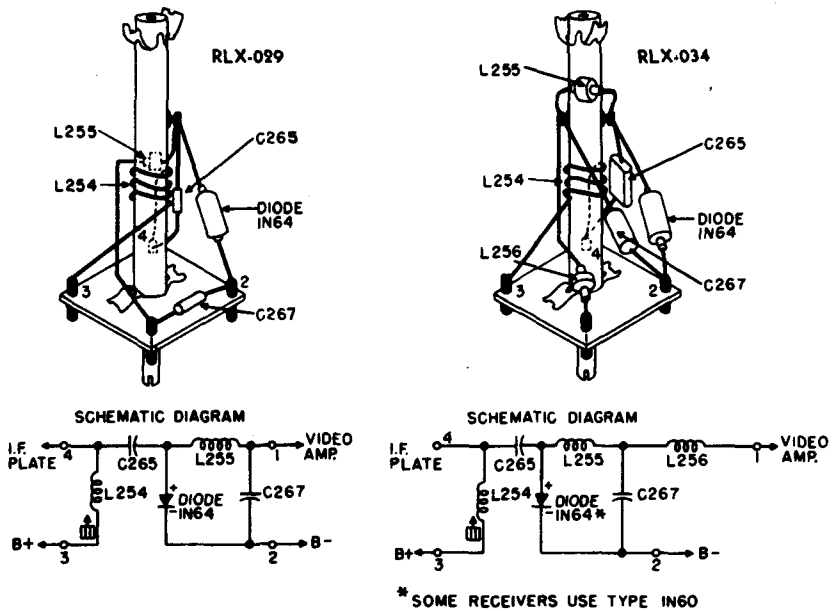

Fig. 27 - General Electric

ohms in connected across the diode. In replacing this diode with normal stock do not use this resistor. In case of doubt check for proper bandwidth.

GENERAL ELECTRIC

Models 17C113, -115, -117, -120, 1717

Reduction of leakage current.

Capacitor C-352, from B- to ground is changed from a value of .05 μf to .02 μf , UCC-041. This is done to reduce the leakage current which flows between B- and ground.

GENERAL ELECTRIC

Models 17C113, -115, -117, -120, 1717

Improving horizontal linearity.

In order to improve horizontal linearity, capacitor C-373 in horizontal-linearity circuit is changed from

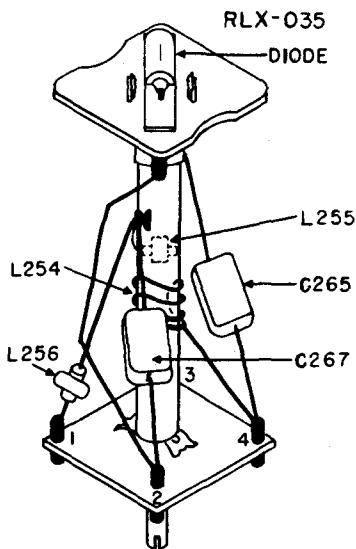

Fig. 28 - General Electric

a value of .1 μ f to 0.06 μ f (part No. UCC-046). At the same time the cathode (pin 8) of horizontal-output tube *V-14*, 25BQ6, is connected directly to ground, removing *R-381* and *C-381*. In late production receivers ion trap RET-003 was replaced by a cunifering, type RET-012, to further improve horizontal linearity.

GENERAL ELECTRIC

Models 17C113,
-115, -117, -120, 17T7

Improvement of first video i-f amplifier.

To equalize gain of the staggered i-f stages, resistor *R-254* (across the first i-f plate coil) is changed from a value of 33,000 ohms to 27,000 ohms with a part No. of URD-083.

GENERAL ELECTRIC

Model 19C101

Centering range of horizontal-peaking control.

A 2,200-ohm, 1-watt resistor, *R-77* (cat. No. URE-1057), is added in series with *R-50* to ground, to move the range of operation of the peaking control to a more favorable point.

GENERAL ELECTRIC

Model 19C101

Reduction of vertical white bars in picture.

To reduce vertical white bars in the picture as the horizontal-peaking control mica capacitor (*C-123*, cat. No. RCU-289) is connected between terminals No. 4 and No. 8 of *T-9*. Another capacitor (*C-124*) of the same value and rating is connected from terminal No. 8 of *T-9* to chassis ground.

GENERAL ELECTRIC

Model 19C101

Increased audio sensitivity.

The audio sensitivity is increased by reducing *R-60* (in the cathode circuit of the audio amplifier) to 47 ohms, 1 watt, approximately half of its original value. It is possible to use two 100-ohm, $\frac{1}{2}$ -watt resistors in parallel, in lieu of the single resistor cat. No. URD-017, 47 ohms, 1 watt.

GENERAL ELECTRIC

Model 19C101

Increasing insulation between connections of deflection-yoke plugs.

To increase the insulation between connections of the male and female plugs connecting the yoke assembly to the chassis, two of the leads are re-arranged as follows:

1. The orange lead from yoke to *T-26* originally connected through pin 1 is moved to pin 2.
2. The brown lead from yoke to arm of *R-88* originally connected through pin 3 is moved to pin 4.

Receivers incorporating this wiring change in production are identified by the letter "G" stamped upon the rear chassis apron.

It is suggested that, whenever a chassis not carrying the later wiring change is out of the cabinet for repair, the alteration described above be made to the plug wiring. Clean thoroughly between the terminals with a stiff brush and alcohol.

Corresponding wiring changes to plugs must be made with chassis not displaying the "G" identification stamping when plug and cable replacement is being made.

GENERAL ELECTRIC

Models 800 series,
805, 806, 807, 817, 821

Horizontal-sync stabilization

(see Fig. 29).

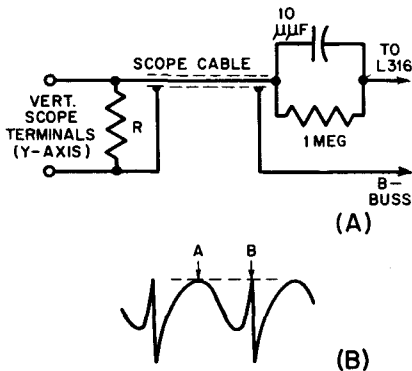

Fig. 29 — General Electric

On the above production receivers, a tuned circuit is added to the horizontal blocking oscillator circuit to stabilize the sync. The method des-

Other oscilloscopes, while their input capacitance may be high, can be used if the special probe shown in part (A) of the figure is incorporated in the test set-up. The value of R for a given type oscilloscope is shown in the table.

The television receiver must first be tuned for normal picture, the usual adjustments of either or both the front panel or rear of chassis horizontal-hold controls being made to obtain horizontal sync. The flywheel coil, L-316, is adjusted for equal amplitude of its positive peaks, A and B, as shown in part (B) of the figure. Keep the picture in sync during adjustment of the flywheel coil by adjusting either or both of the horizontal-hold controls.

After properly setting L-316, the rear-of-chassis horizontal-hold control should be readjusted as described in the service notes.

RESISTORS FOR PROBE

Value of R	Type of Oscilloscope
18,000 ohms	General Electric CRO-3A*
150,000 ohms	General Electric CRO-5A
82,000 ohms	General Electric CRO-5S
82,000 ohms	Dumont Type 208

cribed below uses instruments for adjustment of the circuit which will give better performance than the method described in the service notes.

Connect a low input impedance oscilloscope (General Electric type ST-2A or equivalent) to the junction of L-316, and the horizontal blocking oscillator transformer L-313 through a .05-μf capacitor. Connect the ground side of the oscilloscope to B- of the horizontal-sweep circuit.

*Note: Vertical attenuator set at mid-range.

GENERAL ELECTRIC

Models 801,
802, 803, 805, 806, 807,
809, 810, 811, 814, 820,
830, 835, 840

Improved horizontal-output transformer (see Fig. 30).

A new ceramic-core sweep transformer, stock No. RTO-071, is recommended as a substitute for the original molded horizontal-sweep out-

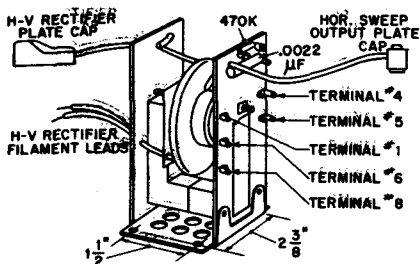

Fig. 30 — General Electric

put transformers for these models. It has several electrical design improvements over the originally specified transformer, among them are higher efficiency and better high-voltage insulation.

The transformer is equipped with a 470,000-ohm resistor in shunt with a 0.0022- μ f capacitor, connected between the primary and high-voltage windings. In order to provide identical electrical characteristics to the original transformers, a few circuit revisions are necessary when the substitution is made. Kits are available which contain all the additional components, except transformers or tube, which are required to make the conversions. Each kit is furnished with an instruction sheet which gives the step-by-step procedure for making the conversion.

GENERAL ELECTRIC

Models 801,
802, 803

Picture distortion at high contrast or brightness setting.

If distortion of the picture is evident when either brightness or contrast is advanced after installation of a ceramic horizontal-sweep transformer, the cause is often that the wire going from pins 2 and 5 of the damping tube 6AS7, (*V-14* in model

801 or *V-23* in models 802, 803) to terminal number 4 of the transformer is dressed too close to the wire that goes from terminal number 5 on the transformer to the blue side of the width coil. Dressing the wire that goes from pins 2 and 5 of the 6AS7 tube along the top of the chassis eliminates this difficulty.

GENERAL ELECTRIC

Models 802, 803

Buzz modulation at high-frequency channels.

A sharp low-frequency audio buzz which sounds similar to a 60-cycle sync pulse reproduction has been isolated to the filament lead that connects to the head-end switch wafer. This hum was noted particularly on channel 13 reception but possibly exists on some of the other high-frequency channels. It is apparent only when tuned to the station. Correct as follows:

Disconnect the filament-supply lead at the point where it connects to the r-f head-end switch wafer (2nd from rear). This filament lead runs between *V-20* and the r-f head-end switch, *S-1*. Wind a choke out of self-supporting #18 insulated wire by close winding 8 turns around a 1/4 inch rod. Slip the choke off the rod and connect it in series with the filament lead and a point of the switch where the lead was originally connected. Connect a 5,000- μ mf ceramic capacitor (RCW-3014) between the junction of the choke and filament-supply lead, to the lug on which *C-147* is grounded. Attach the ground end of this capacitor as close as possible to the ground end of the lug where it assembles to switch back plate. Leads on choke and capacitor must be short.

GENERAL ELECTRIC

Models 805,
806, 807, 809, 817,
818, 821

Insufficient horizontal sweep width.

Insufficient horizontal sweep width may be caused by a parasitic oscillation in the type 19BG6 horizontal sweep output tube, *V-13*. To correct, connect a 47- μmf , 500-volt mica capacitor (stock No. UCU-1020) from pin 7 of the 19BG6 tube to a ground lug of an existing terminal board on the adjacent side apron.

GENERAL ELECTRIC

Models 810,
811, 814, 820, 830,
835, 840

High-channel interference (see Fig. 31).

By the addition of a 1.5-15- μmf trimmer (stock No. RCY-002) to the head-end unit, high-channel interference, such as channel 8 being

received on channel 5 and channel 10 on channel 6, can be reduced considerably or eliminated. As shown dotted in the diagram, the trimmer is connected between the low side of *L-3* and ground. The rotor side of the trimmer should be connected to ground at the ground point to which *R-1* and *C-2* are soldered.

The channel selector switch *S-1* is open on low-channel reception connecting the added trimmer in series with *L-3*. This makes a series-resonant circuit of these components which when properly adjusted will effectively reduce the subject interference. On high-channel reception, the trimmer is switched in parallel with *C-2* (1,500 μmf), making the trap circuit inoperative so that it has no effect on the normal high-channel operation.

With the receiver tuned to the low channel and the interfering high channel station operating, two minimum points of interference will be observed when turning the trimmer from the maximum capacitance position. The first minimum indicates that the trap is tuned to attenuate the high-channel fundamental and the second minimum indicates tuning to the second harmonic of the local oscillator. The best point of adjustment for the least interference is the second minimum point or when the trap is tuned to the second harmonic of the local oscillator. Note: The first minimum gives an attenuation of 45 db, while the second minimum gives approximately 83 db attenuation, making it very important to tune for the minimum interference at the lowest capacitance setting of the trimmer.

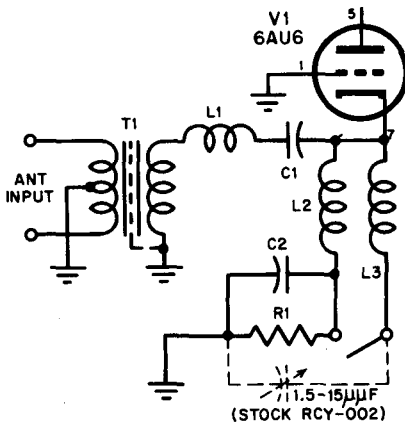

Fig. 31 — General Electric

GENERAL ELECTRIC

Models 810,
811, 814, 830, 835

Audio clicks at various volume-control settings.

Audio clicks heard when the volume control is moved past the tap or at maximum volume setting when operating in a high channel, can be cured by re-dress of the audio shielded leads and placement of components. Proceed as follows:

1. Remove the two shielded audio leads from under the cable clamp which is located on the side chassis apron above the 2nd audio i-f transformer. These audio leads are then dressed out of this clamp so they will be spaced approximately $\frac{1}{8}$ inch away from the chassis side apron.

2. The three paper capacitors (C-87, .01 μf , C-74, .01 μf , and C-76, .02 μf) mounted on the left apron terminal board must be dressed down close to the side apron, as far away as possible from the head-end unit.

GENERAL ELECTRIC

Models 810,
811, 814

Audio buzz due to excessive signals (see Fig. 32).

The addition of bias to the converter grid is sometimes necessary when the receiver was used in strong-signal areas, especially on the high-frequency stations. The peaks of the signal, which are the vertical pulses, cause the tube to draw grid current which, in turn, frequency-modulates the oscillator voltage at the vertical-pulse rate (60 cps). This appears in the audio as a buzzing sound.

Bias is added to the converter grid (pin 7 of V-2B) by the addition

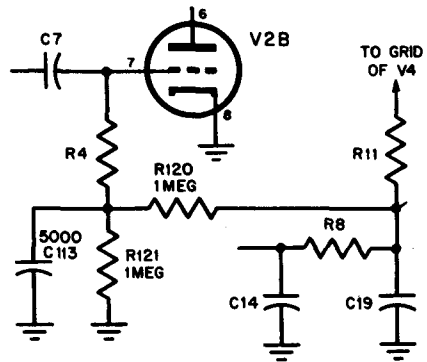

Fig. 32 — General Electric

of R-120, R-121 and C-113, as shown in the figure. Add a terminal board to the underside of the main chassis near the r-f unit. The board should be mounted so that short leads can be used. Remove R-4 from ground under the oscillator trimmer C-80 and connect to the junction of R-120 and R-121 on the new terminal board. Connect C-113 from junction of R-120 and R-121 to the ground point on the r-f chassis under the oscillator trimmer C-80. Note: Dress C-113 as far away as possible from the oscillator trimmer C-80.

Cat. No. for R-120 and R-121 (1 meg, $\frac{1}{2}$ watt) is URD-121. Cat. No. for C-113 (5,000 μf , ceramic capacitor) is RCW-3014.

GENERAL ELECTRIC

Models 810,
811, 814

Removal of vertical-retrace lines (see Fig. 33).

The circuit shown in the figure has been added in late production to remove the vertical-retrace lines which appear when the contrast control is used at a low setting or the brightness control is used at a high

setting. Models not modified may be wired in accordance with the schematic shown with the addition of the following parts: *C-109* (UCC-635) is a .05- μ f, 600-volt capacitor, *C-110* (UCC-631) is a .02- μ f, 600-volt capacitor, *R-118* (URD-059) is a 2,700-ohm, $\frac{1}{2}$ -watt resistor, and *R-119* (URD-1082) is a 24,000-ohm, $\frac{1}{2}$ -watt resistor.

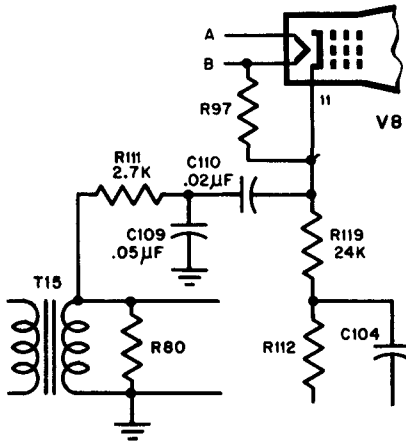

Fig. 33 — General Electric

GENERAL ELECTRIC

Models 810, 811

Reducing horizontal-oscillator drift.

The blocking-oscillator coil *T16* is mounted below the chassis rather than on top as in early production models. This change materially reduces the amount of horizontal-oscillator drift.

GENERAL ELECTRIC

Models 810, 814

Improved audio i-f selectivity.

To improve the selectivity of the audio channel and, thereby, to increase the attenuation to the video

i-f signal and to vertical pulses which might cause hum or noise, a transformer *T-21* has been substituted for *L-5*. The addition of this transformer reduces the audio i-f bandwidth to approximately 300 kc. The catalogue number for this transformer is RTL-090. To replace *L-5* with *T-21*, it is necessary to remove the coupling capacitor *C-98* and coil *L-5*. The primary of *T-21* should be connected between pin 5 of *V-22* and the load resistor *R-102*. Connect terminal 1 of *T-21* to *R-102*. A bypass capacitor *C-106* (cat. No. RCW-3014) must be connected from the junction of *R-102* and terminal 1 of *T-21*, to ground. Terminal 2 of *T-21* should be connected to pin 5 of *V-22*. Terminal 3 of *T-21* must be connected to ground. Terminal 4 is connected to pin 1 of *V-17*.

This transformer mounts in the same manner as *L-5* and is double-tuned. Therefore, when tuning this stage, it is necessary to adjust two iron cores of *T-21* for maximum amplitude and symmetry about the 21.8-mc marker.

GENERAL ELECTRIC

Models 810, 814

Eliminating audio howl.

It has been found that howl may be caused by one or more of the three following reasons:

1. A microphonic converter-oscillator tube, *V-2*, type 12AT7.
2. The capacitor *C-3*, located on the head-end unit under the tuning capacitor, may start vibrating.
3. The metal guide ring on the rear side of the oscillator wafer rotor section or the textolite rotor in the oscillator wafer of the channel switch may be loose.

A lead weight RHX-014 is available from the manufacturer to mount over the type 12AT7 tube, *V-2*, which will dampen out mechanical vibration of the tube envelope and the internal components of the tube.

To prevent the capacitor *C-3* from vibrating, a rubber block, RMM-081, may be wedged between the edge of *C-3* and the front apron of the head-end unit. To facilitate the installation of this piece, it is suggested that it be cut into a V or wedge shape so that the edge of *C-3* will be held in the channel of the rubber cushion.

Item 3 can be corrected by cementing the textolite rotor to the shaft and the rotor guide ring on the rear side of the oscillator wafer rotor to the textolite rotor with *Dekadhes Cement*. Extreme caution should be observed when applying this cement. The cement should only be applied to the guide ring and the textolite rotor. The cement *should not* touch the fingers of the electrical contact ring which extends through the textolite rotor.

GENERAL ELECTRIC

Model 810

Increasing range of brightness control.

Resistor *R-24* plate resistor of the 2nd video amplifier is changed from a 1-watt, 3.3-k to a 2-watt, 3.3-k unit. It was found that the original resistor increased in resistance slightly, therefore limiting the brightness obtainable on the picture tube. The catalogue number for *R-24* is URF-1061.

GENERAL ELECTRIC

Models 811,
814, 820, 830, 835

Eliminating i-f regeneration.

Audio regeneration, which causes a click in the speaker as the tuning control is tuned through the station, can be eliminated by the use of a 5,000- μmf capacitor across the audio i-f B+ lead. This capacitor is connected between the B+ and ground terminals at the terminal board located between the limiter tube socket, *V-18*, and the discriminator transformer *T-19*.

GENERAL ELECTRIC

Model 814

Removing wiggle at top of raster.

To remove a slight wiggle at the left-hand end of the first few lines at the top of the raster, a resistor *R-116*, 330 ohms, $\frac{1}{2}$ watt (cat. No. URD-037) is added in parallel with *C-83*. This capacitor is in series with the horizontal-deflection coils.

GENERAL ELECTRIC

Model 820

Extending high-frequency audio response.

On most of the receivers of series R production, a change has been made in the tone-compensating network connected across the volume control of the tv chassis to extend the high-frequency audio response and reduce some of the "boom" bass compensation. It may be found desirable to change any receiver prior to this where the audio-frequency characteristic is unsatisfactory.

PARTS LIST

C-87 (cat. No. UCC-630)
C-114 (cat. No. UCU-052)
R-96 (cat. No. URD-095)

.01- μ f, paper capacitor
1,000- μ f, mica capacitor
82,000-ohm, carbon resistor

The change involves the removal of the three components connected in the volume-control circuit as shown in the table.

GENERAL ELECTRIC

Model 840

Excessive bass response.

Excessive bass response on television audio and low-frequency rumble when playing the phonograph and when receiving radio programs is corrected by making the following changes in the audio compensation. For the television audio:

1. Change *C-14*, 1,000- μ f capacitor to 470 μ f. This capacitor connects between shield and ground at the volume control of television-receiver chassis.

2. Change *C-135*, 470- μ f capacitor that connects between *R-76* and *C-91* on radio chassis to 1,000 μ f.

This can be done by interchanging these two components without the need of additional components.

For radio and phono audio:

Remove *R-39*, 22,000-ohm resistor in bass tone control circuit of radio chassis. The removal of *R-39* will disconnect a portion of the bass tone control consisting of *C-82*, *C-83*, and *C-84* from the remainder of the circuits without removing the components themselves.

GENERAL ELECTRIC

Models 901, 910

Horizontal-sweep failure in low-line voltage areas.

Failure regarding no picture may be caused by an inoperative horizontal sweep generator tube, *V-14*, which results in no high voltage on the 5TP4 picture-tube anode. In this sweep oscillator, feedback is provided through the common cathode resistor, *R-40*, in the two triode sections of *V-14*. This resistor has a value of 1,000 ohms. However, where low line voltage exists, this may not provide sufficient feedback to maintain oscillation, and it is suggested that the value of *R-40* be increased to 1,200 ohms (URD-051) in all receivers to cure this trouble or insure against a possible service complaint.

GENERAL ELECTRIC

Models 901, 910

Increasing range of vertical-size control.

When insufficient picture height is experienced with adjustment of the vertical-size control, the range may be extended about four inches by shunting *R-118* (2.2 meg) with another 2.2 meg resistor or replacing *R-118* by a 1-meg resistor. *R-118* is one of the plate-charging resistors in the vertical sweep generator tube (*V-11B*) circuit located at the rear of the television chassis.

GENERAL ELECTRIC

Models with

"B-version" head-end unit High-channel instability.

To improve the stability when operating on channels 12 and 13, a

component addition is made as described below. The instability shows up in most cases as a flutter or "motorboat" in raster brilliance when very weak or no signal is present on channels 12 and 13. The trouble may also result in r-f oscillation appearing as alternate black and white horizontal bars. This condition has only been noted since the use of the B-version head-end unit which uses a type 6AB4 tube as the 1st r-f amplifier, *V-1*.

Connect an 800- μmf ceramic capacitor (RCW-3026) from pin 3 (filament) of the type 6AB4, tube, *V-1*, to the head-end unit mounting plate. This mounting plate serves as the B-buss for the head-end unit. Keep the capacitor leads as short as possible.

GENERAL ELECTRIC

All models
using series filaments

Maintaining filament continuity with picture tube removed.

When it is necessary to perform alignment, measure socket voltages, or troubleshoot a tv receiver, it is desirable to remove the picture tube for convenience as well as a personal safety precaution. In receivers with series lighting of the filaments, the removal of the picture tube breaks the continuity of the heater circuit for all tubes and a substitute resistor or suitable filament element must be used to restore continuity. A defective type 6SN7GT tube with a good heater may be used for this purpose.

To prepare the 6SN7GT tube, saw or clip off all base pins except 7 and 8. These are the filament pins and it will be found that they will insert readily into the picture tube socket

pin openings 1 and 12. This will reestablish the continuity and provide proper voltage division on the filament strings.

Note: The keyway on the altered type 6SN7GT will not line up with the keyway slot in the picture-tube socket, however it will not interfere with the insertion of the tube into the socket.

GENERAL ELECTRIC

All models

Transmission-line wave traps.

Occasionally the use of a quarter-wave stub of transmission line is recommended for trapping out unwanted signals or for attenuating powerful interfering nearby tv stations. This is satisfactory as far as the reduction or elimination of the undesired signal is concerned, but it will also cause a change in the r-f response curve of the head-end unit on channels close to the tuned frequency of the stub. This may result in a serious impairment to the picture detail due to smearing.

It has been found that it is much more desirable to insert a small capacitor in series with each line of the stub at the point where the stub fastens to the head-end terminals. These capacitors should be 5 μmf for stubs in the low-frequency tv band and the f-m band, and 2 μmf for stubs used in the high-frequency channels. This gives a series-parallel tuned trap which is much sharper in response and will not affect the response curve of the head-end unit unless the stub is tuned directly in the channel.

The capacitors in the tuning stubs result in a longer piece of line being

used for a particular frequency. The best method of determining the proper length of line is to clip off small portions until maximum attenuation is obtained.



HALLICRAFTERS Models T-54, 505
Low picture brightness.

Poor picture-tube brightness is usually the result of low anode voltage. Adjustment of anode voltage to the recommended value is described in the service note; however, this may result in the observed picture appearing to be folded over horizontally, especially on the left-hand edge. When increasing the anode voltage, set width control to just fill the screen width and increase high voltage until foldover occurs. Readjust width and repeat voltage adjustment until maximum voltage is obtained without foldover.

The foldover indicates that the horizontal sweep limits have been reached. Changing horizontal oscillator or amplifier tubes may provide higher sweep limits, allowing a higher picture tube anode voltage to be used.

HALLICRAFTERS Models T-54, 505
Increasing sensitivity.

The following changes will increase the sensitivity of the above models:

1. Change oscillator-injection capacitor from $.68 \mu\mu\text{f}$ to $1.5 \mu\mu\text{f}$ (part No. 47A160-3). This effectively raises the r-f gain with a considerable improvement on channel 7.

2. A $10\text{-}\mu\text{f}$, 25-volt electrolytic capacitor (part No. 45A121) should be added as a cathode bypass for the 25L6 (V-4) audio-output tube. This effectively raises the audio gain by 6 db and should only be made on sets which use a 6AV6 audio-amplifier tube.

HALLICRAFTERS Models T-60,
T-64, T-67, T-68, 509

Reducing fringe-area snow.

To reduce fringe-area snow by increasing the sensitivity, proceed as follows:

1. Remove capacitors C-9 and C-11 from the push-button tuner.
2. Remove grounding leads from socket terminals 4 of V-1 and 7 of V-2 and ground socket terminals directly to the chassis.

HALLICRAFTERS Models T-60,
T-64, T-67, T-68, 509

Reducing horizontal instability.

To reduce horizontal drift, change R-83 (horizontal oscillator plate load) from 5,600 ohms, $\frac{1}{2}$ watt to a 1-watt unit of the same resistance value (part No. RC30AE562K).

HALLICRAFTERS Models T-64, 509
White horizontal line at top of picture.

In the event that a white horizontal line appears at the top of the picture when the set is switched to "Picture Normal" position, change resistor R-120 (200 ohms, 1 watt, part No. RC30AE201J), which is connected to the Normal-Circle switch, to 390 ohms, 1 watt (part No. RC30AE391J).

HALLICRAFTERS Models T-64, 509
Slow collapse of vertical sweep.

In the event of slow collapse of vertical sweep due to a failure of the vertical linearity control, *R-111*, replace the control. Then, install a 3,300-ohm, 1/2-watt resistor (part No. RC20AE332) from pin 6 of the vertical amplifier, *V-14*, to ground.

HALLICRAFTERS Models 1002
through 1007, 1015
through 1019

Improving horizontal-oscillator stability.

To improve horizontal-oscillator stability, proceed as follows:

1. *R-173* (150,000 ohms), in the grid circuit of the horizontal oscillator, is changed from a 10%, 1/2-watt resistor to a 5%, 1-watt resistor.

2. *C-147* (330 μmf), in the grid circuit of the horizontal oscillator, is changed from a plain mica to a 10% silver mica capacitor.

3. *R-177* (330,000 ohms), in the feedback circuit to the grid of the horizontal-control tube, is changed from a 10%, 1/2-watt resistor to a 5%, 1-watt resistor.

4. *C-179* (68 μmf), which may be found in some chassis as the horizontal-lock adjustment, is deleted to increase the range of the horizontal-range adjustment.

5. The cold end of *C-146* (.05 μf at 600 volts) is connected to the cathode (pin 3) of the horizontal oscillator (*V-115*) instead of to ground.

HALLICRAFTERS Models 1002
through 1007, 1015
through 1019

Improving interlace.

To improve interlace a shield is placed around the sync clipper and vertical oscillator tube *V-107*.

HALLICRAFTERS Models 1002
through 1007, 1015
through 1019

Increasing range of vertical-hold control.

To increase the range of the vertical-hold control, the 820,000-ohm, 1/2-watt resistor (*R-191*) on the high side of the control is changed to 1.2 meg, 1/2-watt. This change was made early in production and consequently few chassis are in the field with the original 820,000-ohm resistor.

HALLICRAFTERS Models 1002
through 1007, 1015
through 1019

Improving retrace blanking.

To improve retrace blanking, the 47,000-ohm, 1/2-watt resistor (*R-138*) between one side of the brightness control and ground is changed to *R-220* with a value of 10,000 ohms, 1/2-watt.

HALLICRAFTERS Models 1002
through 1007, 1015
through 1019

Improving sound sensitivity.

To improve sound sensitivity, the sound take-off point is changed from the plate (pin 5) of the video amplifier to the junction of *L-114* and *L-101* in the video-detector circuit. At the same time, the 2.2- μmf coupling capacitor (*C-112*) is changed to 4.7 μmf and is given a schematic symbol of *C-184*. The plate and screen voltage for the audio i-f ampli-

fier is increased by replacing *R-148* (22,000 ohms, 1/2-watt) with *R-222* (4,700 ohms, 1/2 watt). In the sound-detector circuit, the de-emphasis capacitor *C-130* (1,000 $\mu\mu\text{f}$, ceramic) is replaced by *C-186*, a 2,000- $\mu\mu\text{f}$ ceramic capacitor.

HALLICRAFTERS Models 1002
through 1007, 1015
through 1019

**Preventing vertical foldover and
improving vertical linearity.**

To prevent top-picture fold and improve vertical linearity, proceed as follows:

1. The 2.2-meg grid-leak resistor (*R-213*) for the vertical amplifier (*V-108*) is changed to a 1-meg, 1/2-watt resistor (*R-145*).

2. A 3.3-meg, 1/2-watt resistor (*R-221*) is added between ground and the junction of *R-143* (1 meg, 1/2 watt) and the height control (*R-146*).

3. The vertical-output transformer (*T-114*), part No. 55C189 with a d-c resistance of 1,600 ohms, is replaced by *T-116*, part No. 55C199 with a d-c resistance of 1,400 ohms.

4. The 12,000-ohm, 1/2-watt, 10% resistor *R-214* is replaced by a 10,000-ohm, 1/2-watt, 5% resistor, *R-223*.

HALLICRAFTERS All 10-inch
picture tube models
Reduction of noise.

To reduce noise or snow on the screen in areas of low-signal strength, shield the leads to the contrast control. Ordinary braid shielding may be used to encase the two leads, shielding that portion which appears above the chassis. The braid should be grounded to the chassis.

HALLICRAFTERS All 10-inch
picture tube models
Improved definition.

It has been found that the addition of a capacitor directly across (in parallel with) resistor *R-64* will result in improved picture definition. Resistor *R-64* is in the cathode circuit of the 2nd video amplifier.

The capacitor may have any value from 500 $\mu\mu\text{f}$ to 1,000 $\mu\mu\text{f}$ at 500 volts, 20%. This addition is made in later production runs of the above models. The added capacitor has a part No. of CM20A471M.



HOFFMAN Chassis 135
Insufficient picture width.

The raster width on the 12-inch tube may be too small to fill the mask, even with the width-control slug all the way in. This may be caused by low power output from *V-126* (6BG6G horizontal output) to the deflection yoke. To remedy, try one or more of the following:

1. Move the tap on *R-209* (located inside the high-voltage power supply shield) to the connection at the top of the resistor.

2. Replace *V-126*.

3. Add a .05- μf , 600-volt capacitor across terminals 5 and 6 of *T-109* (horizontal-output transformer).

4. Replace *T-109*.

5. Replace the yoke (*T-115* and *T-116*).

HOFFMAN Chassis 135
**White milky hand at right edge of
raster.**

After a few minutes of operation, the right edge of the raster may begin

to draw slowly toward the center causing the right edge to become a steadily widening milky line. This is caused by the end of each horizontal sweep being nonlinear and losing focus before the start of the next blanking pulse.

To remedy, replace *V-126* (6BG6G, horizontal-output tube) and/or replace *C-186* and *C-188* (connected to horizontal-linearity coil). Failure of either of these capacitors will usually be accompanied by a drop in the voltage at pin 8 of *V-128*.

HOFFMAN

Chassis 135

Horizontal white line.

A horizontal white line approximately $\frac{1}{4}$ inch wide may appear across the picture at all times. Adjustment of the height and linearity controls changes the position of the line. This symptom is due to a transient oscillation in *V-122*. To remedy, replace *V-122* or exchange this tube for *V-116*, 2nd video amplifier. This exchange may be made since the transient oscillation is due to a combination of factors in the circuit, and the same tube will not oscillate as a video amplifier.

HOFFMAN

Chassis 135

Microphonic at high-volume setting.

Pronounced howl may be produced at high settings of the audio volume control; also frequently a non-tunable hum may occur at lower settings of the audio volume control. This trouble is almost always traceable to the head end, and is due to mechanical vibration of some part affecting the local-oscillator frequency. This vibration may occur in the

oscillator tube itself, the fine-tuning capacitor or in the oscillator coils.

To remedy:

1. Make certain that the fine-tuning knob does not bind against the escutcheon plate or the channel-selector knob, and that its shaft rotates freely in the support bearing on the front of the chassis.

2. If the trouble occurs on only one channel or is noticeably more pronounced on one channel than on the others, check that oscillator coil for rigidity of mounting and mechanical strength of connections.

3. Change the local-oscillator tube. This must only be done when a high band (channels 7-13) signal source is available. The tube interelectrode capacitance affects the fine-tuning range on the high band, therefore it is usually necessary to try several tubes in order to obtain one which will give the same tuning on these channels.

4. The following apply only to the Standard Coil head end *RF-3* (Hoffman part No. T9513).

a. Remove the lead shield from the local oscillator tube, leaving the sheet metal shield in place; and be certain that the remaining shield is completely clear of the shield support.

b. Be certain that the variable dielectric disc is firmly in contact with the phenolic block and with the front plate of the fine-tuning capacitor.

HOFFMAN

Chassis 135

Sound bars and/or 4.5-mc beats in the picture (see Fig. 34).

Sound bars appear as alternate light and dark horizontal bars across

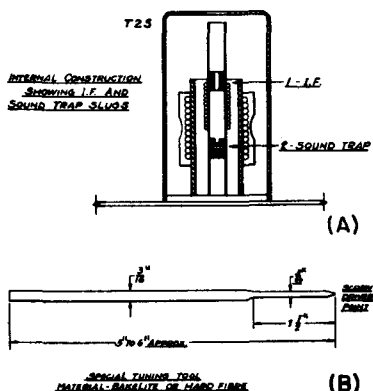

Fig. 34 — Hoffman

the picture which move or vary in synchronization with the received sound. A 4.5-mc beat note appears as a vertical rain-like effect comparable to water running down a window pane. Both phenomena are caused by misalignment of one or more of the absorption wave traps (*T-1*, *T-2*, *T-25*, *T-103*, or *T-105*) in the video i-f circuit. Sound bars indicate the presence of audio frequencies in the video voltage at the picture-tube grid, while the 4.5-mc beat effect in the picture is due to the appearance of a heterodyne signal caused by mixing video i-f carrier and sound i-f carrier. Note: *T-1*, *T-2*, and *T-25* are absorption traps for the sound i-f frequency, while *T-103* and *T-105* affect both the sound i-f interference and the 4.5-mc beat.

If sound bars alone are present, or if both sound bars and 4.5-megacycle beat notes are evident; follow the steps outlined below in order, noting the effect on the picture after each adjustment. If the 4.5-megacycle beat note effect is present without any sound bars, do not retune *T-1*, *T-2*, or *T-25*, but follow steps 2 and 3 in that order.

Tune the receiver to the channel on which the effect is most pronounced, then proceed as follows:

1. *T-1*, *T-2*, or *T-25* adjustment.
 - a. Head end *RF-1* (RCA, Hoffman part No. *T9501*). Adjust the top slug on *T-2* for minimum sound-bar effect.

- b. Head end *RF-2* (Sarkes Tarzian, Hoffman part No. *T9514*). Adjust the top slug on *T-1* for minimum sound-bar condition.

- c. Head end *RF-3* (Standard Coil, Hoffman part No. *T9513*). Adjust *T-25* as follows: Referring to the figure, rotate slug No. 2 *only* to maximum counterclockwise position (normally about 6 turns), then turn it clockwise to the *first* point at which the sound bars are reduced or eliminated. A second resonant point may be found at the lower end of the travel. Do *not* tune to this lower point. A special tool is required for this adjustment, since the only access to slug No. 2 is through a clearance hole in slug No. 1. See the figure for details of the tool required.

2. *T-103* adjustment.

- a. Locate *T-103* on the chassis. In early production runs, *T-103* is tuned with a single 43- $\mu\mu\text{f}$ capacitor, located on the side of the transformer. In later production, a total of 22 or 30 $\mu\mu\text{f}$ has been added in parallel with the original trimmer. This additional capacitance (designated *C-117* on the schematic) may be in the form of two ceramic capacitors of 15 $\mu\mu\text{f}$ each, or of one capacitor of 22 $\mu\mu\text{f}$ or 30 $\mu\mu\text{f}$ +10%, NPO (part No. *T4016*). If the chassis involved is the earlier version, add *C-117*.

- b. Adjust the top slug for minimum sound-bar and/or minimum 4.5-megacycle beat-note effect.

3. *T-105* adjustment.

- a. Locate *T-105* on the chassis.
- b. Adjust the trimmer for minimum sound-bar and/or minimum 4.5-megacycle beat-note effects.

HOFFMAN

Chassis 135

Dark vertical line near left edge of raster.

A dark vertical line may be evident near the left edge of the raster. This is usually more pronounced on channels 11, 12, and 13. The brightness control has some effect on the intensity of the bar, while the horizontal-drive control may eliminate the bar or cause it to divide into two stripes. The above condition is due to transient high-frequency oscillation in the horizontal-oscillator, or the horizontal-output and reaction-scanning sections of the receiver.

To remedy, proceed as follows:

1. Dress leads from A and B terminals of *T-113* (sync discriminator transformer) approximately 3/16 inch away from the chassis.
2. Replace *V-126* (6BG6G, horizontal-output tube).

HOFFMAN

Chassis 140,
142, 143, 146, 147

Tunable herringbone interference on channel 5 (see Fig. 35).

This internally generated interference appears as a fine herringbone pattern in horizontal bands across the picture. The pattern is tunable with the fine-tuning control. As the fine tuning is varied, the size of the herringbone changes, as well as the number of bands across the picture. The interference is caused by a beat note between the 3rd harmonic of

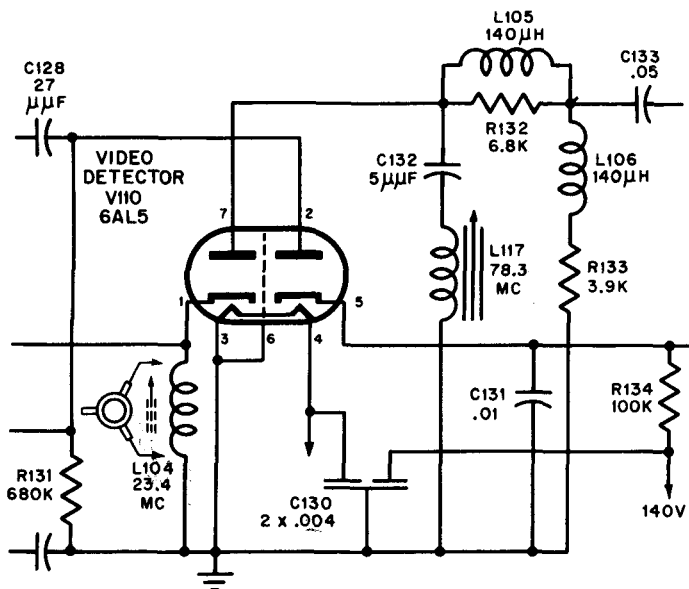

Fig. 35 — Hoffman

the picture i-f frequency (26.1 mc) and the channel-5 video-carrier frequency (77.25 mc). When the fine tuning is adjusted for best sound and picture, the interference appears as a herringbone pattern. It is possible to adjust the fine tuning towards a zero beat between the two signals at which time the pattern degenerates to a series of black and white bands across the picture, giving a venetian blind effect.

This i-f 3rd harmonic is present in the picture 2nd detector and video-amplifier stages. It is coupled back to the input and to the antenna lead-in, mixing with the incoming signals. This condition becomes more apparent in weak signal areas where the amplitude of the 3rd harmonic approaches the amplitude of the desired signal. In strong-signal areas, the channel-5 carrier tends to override the interfering harmonic and very little picture disturbance is produced.

To remedy, the interfering signal must be eliminated at the video detector, *V-110*. Referring to the abbreviated schematic diagram, the video output from pin 7 is shunted by a series-resonant circuit formed by *C-132* and *L-117*. The slug-tuned coil, *L-117*, must be added to the circuit in series with *C-132* to form the series-resonant shunt. For field service correction of the interference, the coil should be mounted in a 5/16 inch hole that can be drilled through the i-f strip chassis adjacent to pin 7 of *V-110*, video-detector tube. The coil is mounted with a tinnerman nut which also holds the tuning-slug screw. It is essential that the tinnerman nut and tuning slug be grounded, which will occur automatically

when the coil is mounted through a hole in the chassis in a manner identical to the mounting of the i-f peaking coils.

The capacitor *C-132*, is at present wired form *V-110*, pin 7, to ground. The capacitor connection to ground must be removed and soldered to one terminal on the coil *L-117*. Ground the other coil terminal to the chassis immediately adjacent to the coil, *not* through a wire back to the former capacitor ground tie-point. The special coil, *L-117*, is part No. 5318 and is available on order from the manufacturer.

Tuning the coil to the i-f 3rd harmonic must be done when a signal is available on channel 5. To increase the interfering signal pick-up, lay the antenna lead-in across the picture tube socket. If the channel-5 signal is strong, disconnect one wire of the twin lead-in from its antenna terminal, leaving an unbalanced input with only one side of the line connected. Adjust the receiver's tuning controls for best picture and sound, and tune *L-117* for minimum herringbone interference. When the antenna lead-in is returned to its normal position, the interference will be eliminated.

HOFFMAN

Chassis 140,
142, 143, 146, 147

**Removing neck shadows (see
Fig. 36).**

A number of remedies are suggested for neck shadows. Any one, or combination of several, may be necessary to clear up the trouble. The primary objective of the remedies is to make certain that the tube is mounted with the neck horizontal, as

compared with the chassis, and exactly centered in the deflection and focus coils. With 15- or 16-inch tubes mounted separately from the chassis, it is generally advantageous and faster to remove the mounting board and tube from the cabinet.

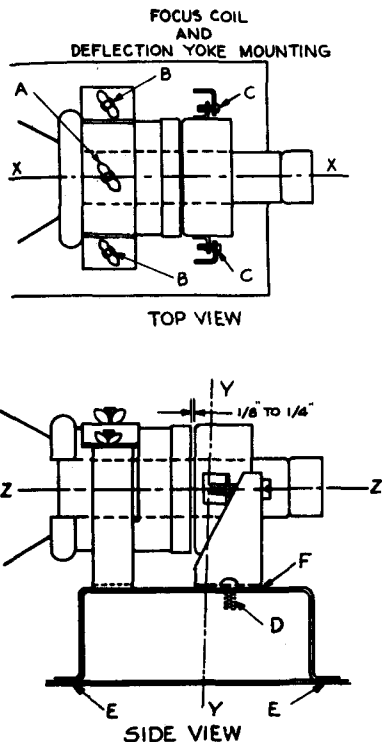

Fig. 36 — Hoffman

Check the tube mounting. It is imperative that the tube neck axis Z-Z, shown in the side view, be level and concentric with the centers of the deflection and focus coils. The front portion (face) of the tube may be raised by shimming with rubber pads under the front rim where the tube is held in place by the vinyl-resin

strap. The rear of the tube may be raised by shimming at points E with thin wood strips or metal washers. On some tubes the axis of the neck does not coincide with the axis of the bulb, and the neck appears to be cocked off at a slight angle. In lining up this type of tube, make the neck level and true with the focus coil to aid in elimination of neck shadows.

Rotate the tube in its mountings. It may be necessary to extend the high voltage lead to accomplish the rotation. This treatment is particularly effective if the tube neck is slightly off center.

Check the positioning of the deflection yoke and focus coil. They should be as far forward as possible. Loosen the wingnut A and slide the deflection coils to their maximum forward position. Loosen wingnut B and slide the entire deflection-yoke bracket securely up on the cone of the tube. Slide the focus-coil bracket as far forward as possible. The bracket is slotted to allow adjustment when hold-down screw D is loosened. Approximately 1/8 inch spacing must be allowed for centering adjustments. The centering adjustment screws C should be 1 3/4 inches long on the 15- or 16-inch tube, and 1 1/2 inches long in the 10- or 12-inch tube for maximum range of adjustment. Be sure to loosen the focus-coil locking-screw, found on 15-inch tubes only, before making any centering adjustments.

Reversing the polarity of the focus-coil field by reversing the circuit connections (yellow and green wires) will often aid in reducing neck shadows. This also reverses the relative motion of the centering ad-

justments C. Best results have been obtained when the left screw (seen from the rear) is the vertical adjustment. Individual exceptions to this general condition may occur.

A non-concentric adjustment of the focus coil is occasionally necessary to allow for proper centering and elimination of neck shadows. Set the centering controls in about their middle range and loosen hold-down screws D. Move the focus-coil bracket by hand to any position that gives the best results. Experimentation is necessary, although a slight forward tip to the bracket and coil often achieves results. When the best position is determined, slip washers under the edge of the bracket at any raised point, (such as under one corner, F), and retighten the hold-down screws to maintain this position.

Slight neck shadow conditions may be hidden if sufficient width control is available to more than fill the picture mask. Move the picture slightly off-center and then increase the width. The shadowed portion of the picture will be hidden behind the tube mask. It is obvious that this is not a correction, and can be used only in minor cases, or as a last resort after other methods have eliminated the major portions of the neck shadow.

The major corrections for neck shadow are all a part of the proper alignment of the tube neck, deflection yoke, and focus coil.

HOFFMAN Chassis 140,
142, 143, 146, 147
High-pitch audio oscillation.

A high audio-frequency tone which is not affected by the volume

control or presence of sound signals can be traced to oscillation in the final audio amplifier. The sound is similar to a microphonic howl, but is not affected by tapping on the chassis. Generally, the amplitude is low and may be partially covered by the sound signal, but it is quite apparent during pauses in speech or music.

To remedy, solder a bypass capacitor, .002- μ f, 600-volts paper tubular (part No. 4118), between plate and screen, pins 3 and 4, of *V-105*, the 6K6 audio-output amplifier tube. This correction has been incorporated in all sets produced after serial No. F909900.

HOFFMAN Chassis 140,
142, 143, 146, 147
Channel-13 picture interference.

A fine herringbone-like interference pattern may occur on channel 13 only, when the sound fine tuning is adjusted correctly for the best sound reproduction. Tuning slightly off the best sound point will usually eliminate or reduce the interference pattern. This interference may also be noted during alignment, showing up when the set is properly aligned and tuned. The interference will disappear or diminish when the sound i-f string is misaligned, often requiring only a slight detuning of the 2nd sound i-f to eliminate the interference.

The above effect is usually caused by regeneration in the sound i-f string because failure of the electrolytic capacitor, *C-108*, to act as an efficient r-f bypass allows the interfering signal to get into the picture amplifiers, thus causing an interference pattern on channel 13.

The combination screen and cathode bypass capacitor for *V-102*, 2nd

sound i-f, is a dual-type, .004- μ f capacitor. This should be removed and replaced by two separate .005- μ f ceramic-type capacitors (part No. 4029). An additional bypass (.005- μ f ceramic, part No. 4029), should be placed in parallel with the ratio-detector load capacitor, *C-108*.

These changes do not affect the sensitivity of the sound i-f; yet they make the i-f strip less "hot" for ease in tuning and alignment, in addition to eliminating the interference on channel 13.

HOFFMAN

Chassis 140,
142, 143, 146, 147

Channel-11 picture interference
(see Fig. 37).

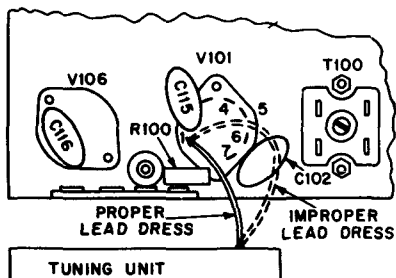

Fig. 37 — Hoffman

Receivers with the above listed chassis produced prior to serial No. E906732, used the conventional sound i-f take-off from the tuning unit. In these chassis, a number of cases of interference in the form of a fine herringbone pattern on channel 11 only have been observed.

Improper lead dress of the sound i-f lead (short lead, white with green tracer) from the tuning unit to pin 1 of *V-101* has been the cause of

trouble in each of the cases observed. When this lead, which goes to pin 1 of the 1st sound i-f grid, is dressed across or near pins 5 or 6, plate and screen connections respectively of *V-101*, coupling and feedback to the grid circuit are introduced. Apparently, an oscillation of such frequency as to cause interference on channel 11 only is set up.

Dressing the grid lead away from pins 5 and 6 will stop the interference. Proper location of the lead is a position running directly from the tuning unit to pin 1 of *V-101*. This will allow the lead to pass over and above R-100, 100-ohm, 1/2-watt cathode-bias resistor. This lead dress should be checked on all sets requiring service for any reason.

HOFFMAN

Chassis 140,
142, 143, 146, 147

Improvement of a-m rejection of ratio detector (see Fig. 38).

Distorted sound may be the result of multipath effects in certain locations which cause random amplitude modulation of the signal. Critical fine-tuning adjustment is required, inasmuch as it is necessary to have the sound ratio detector exactly zeroed to obtain maximum a-m rejection, and least distortion. Certain changes in the detector circuit may be made. These changes reduce the response of the ratio detector to a-m components in the signal, thereby giving better a-m rejection and reducing multipath distortion. In addition, greater audio recovery from the i-f signal gives more audio output, and the response to ignition and other noises is increased. To modify the ratio detector, proceed as follows:

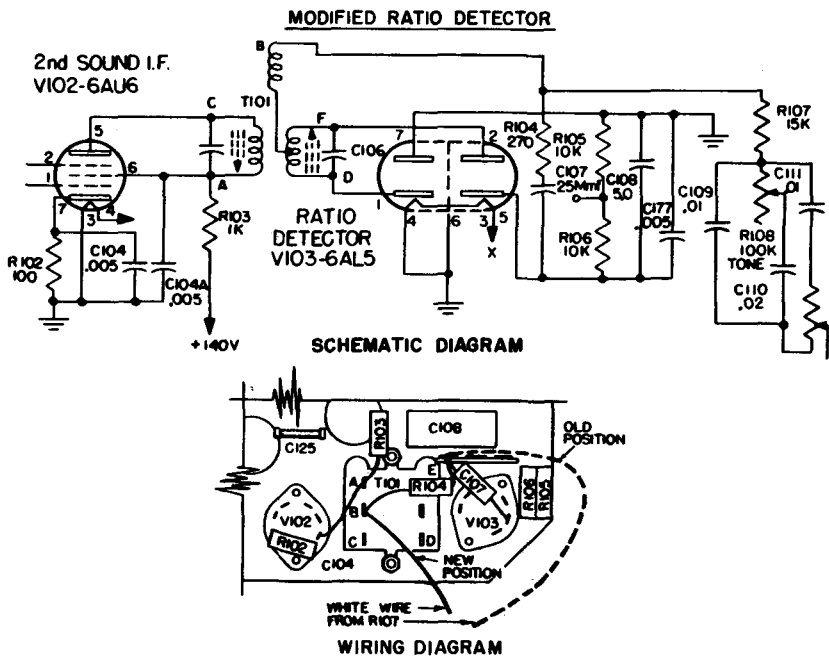

Fig. 38 — Hoffman

1. Change present ratio-detector transformer (*T-101*) from part No. 5305 to No. 5305-1. This new transformer has reduced primary-to-secondary coupling.

2. Increase the value of *C-107* (one side of which is connected to pin 5 of *V-103*) from 1,000 $\mu\mu\text{f}$ to 30 $\mu\mu\text{f}$ (part No. 4043).

3. Change white wire connected from *R-107* to the junction of *R-104*, *C-107* so that it is now connected from *R-107* to terminal B on *T-101* as shown in the figure.

These changes are already made in late production runs of the above chassis.

Whenever *T-101* is replaced for any reason, it is desirable to replace the transformer with a new type (No. 5305-1) and make the wiring

and capacitor changes. It is possible to effect a partial improvement of a-m rejection in present sets by making the capacitor and wiring changes. Realignment of the ratio-detector transformer is necessary when any of the changes are made.

A preliminary method may be followed for field alignment:

1. Tune in a tv signal for best picture. This is best adjusted by tuning for minimum 4.5-mc beat which shows up as a grainy appearance, particularly in the vertical-resolution wedges.

2. Tune top slug of *T-101* for clearest sound. Tune in both directions until distortion appears, then adjust midway between these points.

3. Tune bottom slug of *T-101* for maximum sound amplitude and best quality.

HOFFMANChassis 140,
142, 143, 146, 147**Video i-f peaking for fringe-area reception (see Fig. 39).**

The video i-f string may be peaked for additional gain at a sacrifice of bandwidth to aid reception in low-signal areas. The procedure is set up on the basis that the adjustments may be made in the field without the aid of a sweep generator or scope. All adjustments on the i-f coils are reached from the top of the chassis, and may be accomplished without removing the chassis from the cabinet in sets produced prior to serial No. E906732.

1. Adjust *L-102* (plate circuit of 2nd video i-f) counterclockwise $1\frac{1}{2}$ turns.

2. Adjust *L-103* (plate circuit of 3rd video i-f) clockwise $\frac{1}{2}$ turn.

3. Adjust *L-104* (plate circuit of 4th video i-f) counterclockwise 1 turn.

Fine trimming of the i-f tuning may be accomplished with a sweep generator and scope. The resultant i-f characteristic will have approxi-

mately twice the gain of the normal amplifier, and will have a bandpass of about 3 megacycles between 50% points. This bandpass characteristic applies to all sets, regardless of sound i-f take-off points.

Average i-f bandpass characteristic curves are illustrated to give a comparison of the normal production alignment and the peaked alignment, and may be used as a general guide when the waveform is observed on a scope. The greatest change has been made in the low-frequency portion of the characteristic curve, and the 26.1-mc video i-f carrier must be maintained in its same relative position at approximately 60% up on the straight portion of the slope.

HOFFMAN

Chassis 140, 142, 146

Arcing at h-v rectifier socket (see Fig. 40).

A continuous frying noise from the high-voltage rectifier tube socket location, sometimes accompanied by audible periodic popping and momentary compression of the picture or raster is caused by arcing in the high-voltage rectifier circuit. During periods of high humidity, a leakage path is formed for high voltage between the corona buttons (see part (A) of the figure) and the metal-retaining ring holding the 1B3GT tube socket. This ring assumes a high potential and then discharges to the grounded metal bracket which holds the bakelite platform.

To remedy:

1. Remove the 1-meg resistor, *R-188*, (see part (B) of figure) from pin 2 of 1B3GT socket and corona ring.

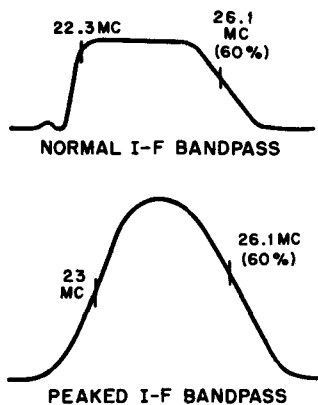

Fig. 39 — Hoffman

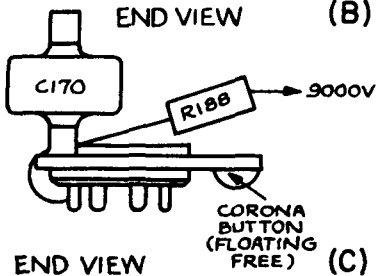
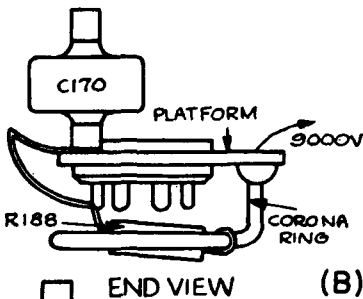
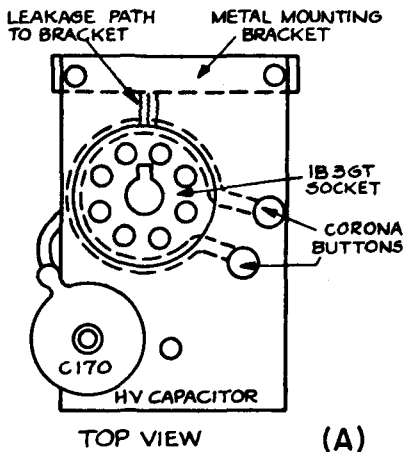

Fig. 40 — Hoffman

2. Solder on end of the resistor to the solder lug at the base of the h-v capacitor C-170 (see part (C) of figure).

3. Remove the h-v lead from the corona button and attach directly to the remaining end of R-188. Make a

smooth solder connection at this point and tape.

4. Take up slack in h-v lead by means of clamp holding lead to cage.

5. Remove unused corona ring by heating unused corona buttons. Part (C) shows final wiring.

HOFFMAN Chassis 140, 142, 146
Unstable vertical sync (see Fig. 41).

Unstable vertical sync is characterized by a picture that tends to jump or bounce in a vertical direction. At times it appears that only part of the picture is affected. Operation of the vertical-lock control is normal, and will hold the picture in sync over a normal range of the control. The vertical bounce caused by noise pulses occur erratically, except when consistent noise conditions are present, and the picture appears to jiggle. Occasionally, the picture will skip one frame vertically. These conditions, in a few cases, are accompanied by spasmodic horizontal tearout of the picture, which is caused by high amplitude noise pulses.

Modification of the sync separator and sync clipper circuits will provide better rejection of noise signals and faster recovery from the effect of noise pulses of high amplitude. The circuit modifications and part changes are listed below.

1. Change R-145 (between video-amplifier plate and the input of the 1st sync separator) from 2,700 ohms to 5,600 ohms part No. 4629).

2. Change R-147 (in above circuit) from 1 meg to 20 megs (part No. 4626).

3. Change wiring of R-147 which was connected from pin 1 of V-112 to ground to parallel C-138.

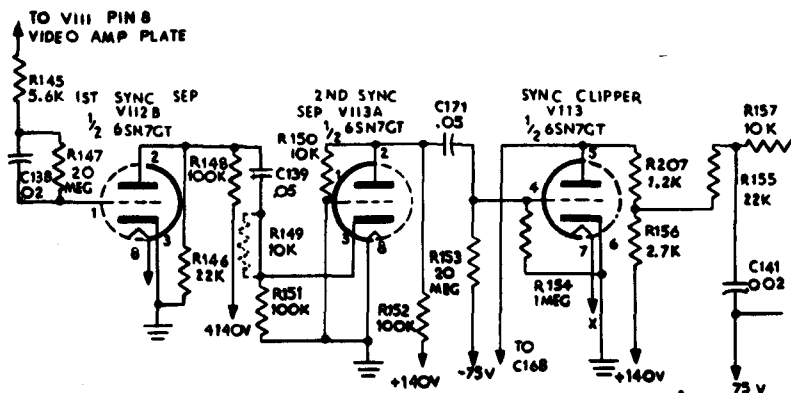

Fig. 41 — Hoffman

4. Change *C-138* (also in above circuit) from .05 μf to .02 μf at 600 volts (part No. 4124).

5. Short out or remove *R-149* (between two sync separators) from the circuit.

6. Change *R-154* (grid circuit of sync clipper) from 680,000 ohms to 1 meg, $\frac{1}{2}$ watt, 10% (part No. 4614).

7. Insert *R-207* (1,200 ohms, $\frac{1}{2}$ watt, part No. 4553) between pin 5 of *V-113* and *R-156* to form a voltage-divider network for vertical-sync pulses.

8. Change the wiring of *R-155* which was originally connected to pin 5 of *V-113*. This resistor should be connected from the junction of *R-207* and *R-156* to the tie-point junction of *R-157* and *C-141*.

These modifications have been made on all receivers produced after serial No. G910973. The figure is a schematic diagram of the sync circuits showing the modified wiring and new parts values. The resistance value of *R-145* is 10,000 ohms in sets prior to serial No. E904712, and must be changed to the new value. Removal of *R-149* from the circuit, and

reconnection of *C-139* to *R-151*, produces an empty tie-point that may be used for the junction of *R-207*, *R-156*, and *R-155*.

Two additional changes that have been made in production to aid in stabilizing the vertical sync should be included in all sets at the same time that modification of the sync circuit is accomplished. The portion of the circuit in which these changes are made is not shown in the figure. These changes are as follows:

1. Change *C-128* (in the output of the 4th video i-f amplifier) from 100 μf to 27 μf , 10% (part No. 4048).

2. Increase the value of *R-167* (in series with the vertical-size control) from 47,000 ohms to 220,000 ohms, $\frac{1}{2}$ watt (part No. 4618) to improve B+ regulation for *V-114A*.

The changes outlined for modification of the sync circuits apply to sets operated in low-signal areas, where the average noise level approaches the signal level. In areas where normal signal and noise conditions exist, no advantage is gained by modifying present sets now in operation.

Conditions of weak signal with very heavy noise or high amplitude noise pulses may exist in a few locations. In these cases, a different time constant for the *R-147—C-138* circuit will give better noise rejection performance. For better noise rejection, use .25 μ f, 600 volts for *C-138* and 1 meg, 1/2 watt for *R-147* in place of the values given above. The circuit wiring will still be the same as shown for either of the alternate sets of components. Better noise rejection is gained at the expense of sync separation, and vertical lines in the picture may exhibit slight waves or curves. The use of this alternate modification is limited to special circumstances best judged by the individual serviceman.

This alternate modification will not be accomplished in factory production, and is primarily intended for a field service measure in special cases.

HOFFMAN Chassis 142,
146, 149, 150, 154
Increasing range of focus control
(see Fig. 42).

Insufficient adjustment range of the focus control (*R-172*) has occurred in 12-inch chassis using the Dumont 12QP4 picture tube. The 12QP4 tube requires more focusing current through the focus coil than other 12-inch tube types, and maximum counterclockwise rotation of the focus control will not bring the tube to its optimum focus.

Circuit changes to increase the amount of current through the focus coil can be accomplished by changing one resistor and adding another resistor, as shown in the accompanying diagram.

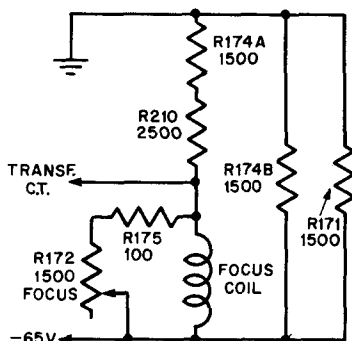

Fig. 42 — Hoffman

1. Decrease the value of *R-171* from 2,500 ohms to 1,500 ohms, 5 watts (part No. 4715).

2. Add *R-210*, a 2,500-ohm resistor (part No. 4714) in series with *R-174A* (1,500-ohm unit).

The 2,500-ohm resistor formerly used as *R-171* may be used as *R-210*. The 1,500 ohms resistor now used as *R-171* should be the wire-wound type. *R-174A* and *B* are a single large Candohm resistor, center-tapped to form the two sections.

These changes will increase the current through the focus coil, and bring the adjustment of the focus control near the center of its range. These changes have been made on all sets produced after serial No. H913661.

HOFFMAN Chassis 143, 147, 151
Staggered interlace patterns.

A ragged interlace action shows up on some 16-inch sets. This action is noticeable particularly on vertical lines, or on the circle portion of a test pattern. The edge of the raster also appears jagged. Alternate trace lines of the raster are displaced so that a ragged effect is produced in the picture.

A degenerative action of the horizontal sweep a-c component occurs in the cathode-bias circuit of the 6BG6 horizontal-output tube. The screen bypass capacitor is returned to the cathode of the 6BG6, which means that any bypassed a-c components from the screen pass through the cathode circuit. The cathode is also bypassed, but some degeneration does occur.

To remedy this condition, the screen bypass capacitor, a .05- μ f paper tublar, should be returned to the -100 volt string instead of to the cathode of the 6BG6. A convenient way to make this connection is to remove the capacitor lead from the cathode, pin 3, and resolder it to any convenient -100 volt point, such as the opposite end of the 100-ohm cathode resistor. The -100 volt string is wired with white wire so that it is easily identified.

HOFFMAN Chassis 143, 151, 152
Vertical white line on left side of picture.

A vertical white line occasionally appears in the left portion of the picture, about two to four inches from the left side on some receivers with 16-inch picture tubes. The vertical disturbance may appear in any form from two light, slightly displaced traces to a broad, fuzzy band. The actual condition is a foldover of the raster, and the edge of the raster appears as if it were behind the picture a few inches from the edge.

If the horizontal-sync pulses are viewed on an oscilloscope, the position of the vertical line will be indicated by two small pips on the

sawtooth portion of the horizontal-sync trace.

The coupling capacitor to the grid of the 6BG6G, horizontal-output tube, is at present a .01- μ f, 400-volt paper tubular capacitor (part No. 4112). This is shown as *C-161* in the schematic digram in the service notes.

A change to .001- μ f, 500-volt ceramic tubular capacitor will eliminate most cases of the left side vertical white line. Do not decrease the capacitance below .001 μ f, as coupling capacitance below this value tends to cause a right side foldover. The part number of the new capacitor is 4025.

HOFFMAN Chassis 143, 147
Increasing range of vertical-linearity control.

The relative range of the vertical-linearity control, *R-169*, can be increased by reducing the value of the series cathode resistor, *R-168*, to 150 ohms. This may be accomplished by replacing *R-168* or paralleling the present 560 ohms with an additional 220-ohm resistor.

HOFFMAN Chassis 143
Elimination of audio buzz.

The unshielded location of the volume control, *R-109*, may allow a low-frequency buzz to be introduced into the audio system from the pulse voltages applied to the picture tube.

An additional metal shield around the volume control has been added on all production sets manufactured after serial No. F907760. The shield is a tent shaped piece of metal that snaps into place and is held by the side channels of the remote tun-

ing control bracket. This installation is made without tools. The shield is most easily snapped into the channel at a position roughly over the contrast-brightness controls, and then slid, in the channel, down over the the volum-tone controls.

Installation of this shield in the field, on sets produced prior to serial No. F907760 can be made in this same manner, to aid in the elimination of an audio buzz. This shield is available and may be ordered to fill individual requirements.

As part of the original set-up adjustments on a new receiver, check to see that the shield is in its proper place, and has not become dislodged or slipped down during shipment.

HOFFMAN Chassis 146
Power-cord interlock looseness (see Fig. 43).

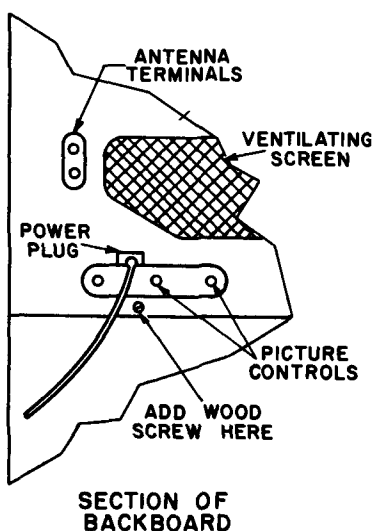

Fig. 43 — Hoffman

The receivers are manufactured with the power cord permanently fastened to the masonite backboard and interlocked in such a manner that the power plug is automatically removed when the backboard is removed. Natural springiness of the backboard tends to pull the power plug from the interlock socket even when all parts are in their normal positions. To prevent the plug from unintentionally being removed from the socket, sets manufactured after serial No. E906729 will have a re-designed power-plug mounting.

On sets of prior manufacture, the problem can be satisfactorily solved by putting an additional wood screw, #6, 1" length, through the backboard and into the wood chassis shelf at a point below the power plug. This additional screw will spring the backboard in, and hold the power plug firmly in place. The sketch of a section of the rear of the tv receiver indicates the approximate position of the additional wood screw.

HOFFMAN Chassis 146
Elimination of oscillation in sound channel (see Fig. 44).

Under no-signal conditions, the receiver sound system may break into a low-frequency motorboating when the channel selector is set on any of the low-frequency channels. Channel 3 produces the worst condition. When switched to the high-frequency channels, the motorboating gives way to a high frequency rough note that sounds like a bad condition of noise hash. This condition also affects the raster when no video signal is present, appearing as grainy horizontal lines similar to heavy

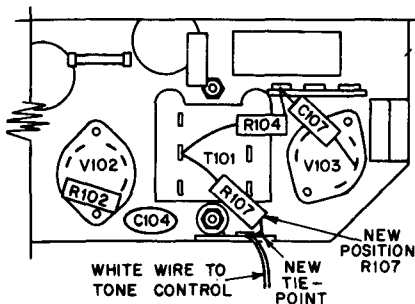

Fig. 44 — Hoffman

noise conditions. This oscillation or motorboating disappears when video and sound signals are present. It has appeared only on consolettes with the remote tuning controls. No indications have been observed on any of the other models. This condition should not be confused with audio buzz or oscillation in the audio-output tube, both of which are noticeable whether or not signals are present.

The long lead to the remotely-located tone-control produces a feedback circuit which allows oscillation to occur. The remedy described below has been accomplished in production on all sets produced after serial No. F904866. This change has been made in all models to eliminate any possibility of future difficulty.

Move the location of the audio-coupling resistor, *R-107*, 15,000 ohms, $\frac{1}{2}$ watt. An additional tie-point is mounted under one of the hold-down screws for *T-101*. The resistor *R-107* is moved from its present location at the tone control, and wired between terminal B of *T-101* and the new tie-point. The white wire previously connecting terminal B and *R-107* may be connected from the new tie-point to one end of the

tone control where *R-107* was previously wired.

The relocation of *R-107* should be accomplished whenever a modification of the sound detector is made on chassis produced prior to serial No. F904866.

HOFFMAN

Chassis 153,
156, 157, 164

Sync instability in noisy locations.

Sync instability, indicated by picture jitter, has been observed on some sets using the above chassis with 19-inch round and 16-inch rectangular picture tubes in noisy locations. This instability is caused by large amplitude noise pulses getting through the video amplifier (*V-III*, type 6AG7) and upsetting the sync system.

For improvement of sync stability, this tube should be replaced with a type 6AC7. The output of 6AC7 is slightly lower, and operates in such a manner as to provide peak limiting of large amplitude noise pulses. The two tube types have identical socket connections and a direct interchange is possible when going from a 6AG7 to a 6AC7 tube type. The 6AG7 tube draws more plate current than a 6AC7, so the reverse interchange of a 6AC7 to a 6AG7 is not recommended in sets of previous manufacturing which used a 1-watt, 3,300-ohm plate load resistor. The chassis which have 2-watt, 3,300-ohm plate-load resistors allow use of either tube interchangeably.

HOFFMAN

Chassis 156,
157, 159, 160, 164

Grounding picture-tube coating.

On some picture tubes, the aquadag coating is not formed down far

enough to contact the ground springs attached to the deflection-yoke bracket. Most tubes are satisfactory. The manufacturer has painted extra coating on initial equipment tubes which require this treatment. However, the length of coating must be considered if tube replacement or change is made by the serviceman. The coating can be extended with a paint formed of graphite held in a lacquer vehicle suspension.

HOFFMAN Chassis 156, 157, 164
Insufficient picture width.

Lack of width is evidenced by the picture being too narrow to fill the mask, even though the width control and horizontal drive are set for maximum horizontal size. The remedy for this condition is to provide more horizontal output, and can be accomplished by two changes.

1. At the present time, the heater voltage for the 6CD6G tube is derived from a common heater string, and falls below the 6.3-volt rated value. To bring this heater voltage to normal, remove the present heater wire from the circuit, and replace it with a separate, No. 18 wire which is to be connected directly to the 6.3-volt tie-point near the power transformer.

2. Increase the horizontal drive (by decreasing the value of *R-182* in series with the horizontal-drive control) to 100k ohms, 10%, ½ watt, part No. 4571.

HOFFMAN Chassis 156, 157, 164
Shadows at top of raster.

At low contrast-control settings, the top of the raster may tend to be-

come dark or shadowy. This effect can be eliminated by adding a .01- μ f, 400-volt, paper capacitor to the retrace elimination circuit. Connect one lead of the .01- μ f capacitor to the junction of *R-221* (3,300 ohms) and *C-188* (.022 μ f). Connect the other lead to ground. Make sure that the outside foil of the capacitor is the ground terminal.

HOFFMAN Chassis 156, 157, 164
Centering range of horizontal-hold control.

Initial setting of the horizontal-hold control as described in the service notes is at maximum clockwise rotation, and the control range is spread over only a small portion of the control rotation. To approximately center the control range, a change can be made in the afc phase comparator circuit. The resistor, *R-199* (connected to pins 1 and 2 of *V-116*), should be reduced from 10,000 to 3,900 ohms, 20%, 1 watt, composition type.

This change also affords a better horizontal sync hold-in characteristic. The horizontal frequency control, *L-111*, should now be set with the horizontal hold control, *R-181*, in the center of its range.

HOFFMAN Chassis 156, 157, 164
Insufficient width.

Early production using a revised high-voltage circuit was built with the common heater cathode connection of *V-121*, 6W4GT damping diode, wired to terminal 4 of the horizontal-output transformer. This connection produces greater than normal high voltage and less horizontal-sweep out-

put. The proper connection is to terminal 5. The horizontal output to the horizontal-deflection coil remains connected to terminal 4. Although most sets will have correct wiring, these connections should be checked.

If sweep width is insufficient with the damper diode connection properly made, additional width can be obtained by connecting a 620- μmf , 1,500-volt capacitor, part No. 4058, between terminals 2 and 4 of the horizontal-output transformer, *T-107*.

HOFFMAN Chassis 156, 157, 164

Bending of vertical lines.

Vertical lines in the picture, such as a door jamb, folds in draperies, or similar vertical objects, may appear to have a curve, bow, or bend in the top portion of the picture. This condition is sometimes called "hook" and results from nonlinearity of the horizontal sweep. Receivers with the revised high-voltage circuit produced prior to serial No. DO36208 have a horizontal sweep comparison feedback network composed of *C-159*, .05 μf , and *R-199*, 3.9k ohms, connected to terminal 2 of the h-v transformer, *T-107*. To aid in eliminating hook, all sets produced after the above serial number have a revised feedback network *C-159*, .005 μf and *R-199*, 10k ohms, connected to terminal 3 of *T-107*.

If some bending still persists, it may be caused by "hash" appearing in the bootstrap B+ voltage. This can be filtered out and eliminated by placing a 10- μf , 600-volt, electrolytic capacitor from terminal 1 of the horizontal-output transformer, *T-107*, to the +265 volt string. This can be

illustrated schematically as being directly in parallel with *C-164*, .1 μf . Return of the capacitor to B+ instead of ground is made to avoid placing too high a voltage on the electrolytic.

HOFFMAN

Chassis 159,
160, 170 through 176,
180, 183 through 187

Reduction of buzz in sound.

Occasionally a 60-cycle buzz problem is encountered in the sound output of tv receiver types listed for this note. The buzz is caused by a 60-cycle ripple voltage on the agc buss. The ripple comes from 60-cycle pulses of varying degrees of amplitude originating from the vertical-sync pulse. The time constant of the RC filter network in the agc buss is short enough to pass a considerable portion of the pulse. By increasing the time constant of the filter, the pulses can be attenuated so that the 60-cycle variations are filtered effectively.

There is a practical limit to how much the time constant can be increased, however, because it is desirable that the agc follow signal fading and airplane flutter. It is recommended that the RC time constant be increased by increasing the value of *C-402* from .005 μf to .22 μf . For extreme cases of buzz, change *C-402* to an electrolytic capacitor within the value from 2 μf to 4 μf ; the voltage rating need be only 10 volts. A convenient point to connect the grounded side of the capacitor is to the ground lug of the tie-point strip associated with the secondary lead of the audio-output transformer.

HOFFMAN

Chassis 159,
160, 170 through 176,
180, 183 through 187

Interference trap for channel 2 (see
Fig. 45).

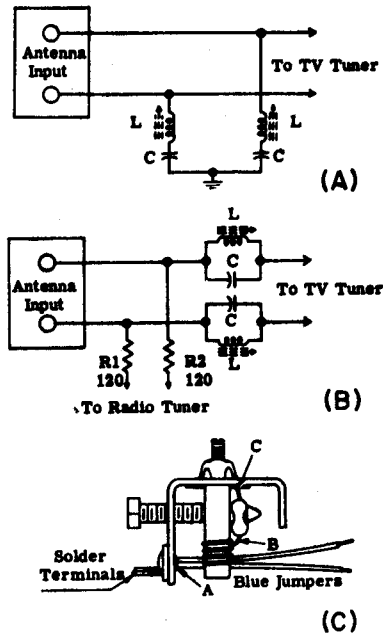

Fig. 45 — Hoffman

A herringbone interference pattern which varies in appearance and intensity is being received on channel 2 in areas where a strong interfering signal lying within the 100-108-mc range of frequencies exists. This interference is an image problem; the interfering signal heterodynes with the receiver local oscillator channel 2 frequency of 81.35 mc to produce a difference frequency lying within the picture i-f band-pass. One important source of interfering signal has been f-m broadcast signals lying within the 100-108-mc band.

The solution to reducing the interference pattern is to trap the interference signal before it enters the r-f stages of the receiver. A special, 88-108-mc trap is available on order from the manufacturer which can be installed at the rear of the receiver on the antenna binding post bracket. The trap consists of a pair of series resonant LC circuits which are balanced to ground. The inductance is variable in order that the trap may be tuned within the approximate limits given. The two series-resonant circuits offer a low-impedance path between antenna and ground to the resonant frequency (interference frequency); very little voltage is developed across the input to the r-f stages at this frequency. It is this low impedance characteristic that makes it necessary, in some cases, to convert the trap to a parallel resonant circuit when it is installed on a tv-radio combination receiver. A comparison of parts (A) and (B) of the figure should reveal that the series-resonant trap will bypass the f-m signals near its resonant frequency, and these signals would be detected somewhat weaker. If the f-m signals which are subject to being trapped are weak or are only moderately strong, the trap should be converted to a parallel-tuned circuit. If these signals are strong local signals, enough signal will be picked up by the tuner and line connected between tuner and rear antenna post bracket to provide adequate excitation, and the series trap can be used without modification.

See part (C) of the figure for conversion details. Unsolder capacitor lead from point C and resolder to point A, unsoldering blue lead from

point A at the same time. Resolder blue lead at point B. This procedure applies to both sections of the trap assembly. The parallel resonant circuit will offer a very high impedance to its resonant frequency (interfering frequency), but it will pass all other frequencies with little or no attenuation. The series-resonant trap provides more rejection, and that is why it should be used where applicable.

Installation of the trap is as follows:

1. Unsolder 2-wire line from antenna terminals at rear antenna plate (not at tuner).

2. Hold trap assembly slightly away from high-voltage cage side of bracket so that the two blue leads may be soldered to lugs at antenna terminals.

3. Slip trap over edge of antenna terminal bracket so that the screw may be tightened with a hex wrench or screwdriver against its rear (cage) side. This should then hold assembly tightly in place.

4. Resolder 2-wire line to terminals at rear of assembly.

5. Set coils so that cores are fully included in winding.

6. Turn on set and tune to channel 2, back out screws slowly one at a time to eliminate interference and give best picture. This should require about three or four turns, or less, on either coil.

HOFFMAN Chassis 159, 160

Focusing of various picture tubes
(see Fig. 46).

Rectangular 14- and 16-inch picture tubes of various manufacturers require different focus coil field strengths. The present focus coil is

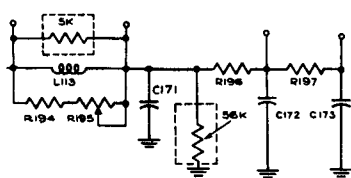

Fig. 46 — Hoffman

suitable for use with all types, provided that circuit arrangements are made to give the proper amount of current flow through the focus coil.

Hytron and GE tubes require less current and a 5k-ohm, 5-watt resistor must be shunted across the focus coil, *L-113*. Sylvania tubes require more current, and a 56k-ohm, 2-watt resistor should be shunted across *C-171* to increase the current through the focus coil. These changes are illustrated schematically in the diagram.

The appropriate circuit modification for the tube used is made in the factory. However, if a tube is changed in the field for any reason, circuit modifications may be necessary. These circuits apply in most cases. Occasionally a tube will require slightly different resistance values.

HOFFMAN Chassis 159, 160
Buzz in sound.

A buzz of basically 60-cycles frequency may appear on some stations and not on others in the same area. The buzz is different from a 60-cycle hum in that it is rough or raucous sounding. The cause of the buzz is in the transmitting station characteristics, and may result from excessive video amplitude modulation, or phase modulation of the video carrier in the final stages of the transmitter.

Three things may be done which will materially aid in eliminating buzz reception by the receiver.

1. Retrim the tuning of the ratio-detector secondary. Tune the receiver to the station which gives the greatest buzz. Tune the top slug of *T-102* for minimum buzz. This slug may be reached from the top of the chassis. The results obtained by tuning the slug for minimum buzz while listening to an offending station will be better than those obtained when aligning to a 4.5-mc signal generator.

2. Change the value of *R-107*, ratio detector load resistor, from 12k ohms to 6.8k ohms. This change affords a considerable improvement in the buzz rejection, and has been made on all sets produced after serial No. E040192.

3. Increase the capacitance of *C-109* (connected to the volume control) from .0047 μf to .01 μf . A 200-v paper capacitor is suitable for use. This change has been made on all sets produced after serial No. C023200 and will aid the previously described changes in reducing buzz.

HOFFMAN

Chassis 159, 160

Curvature in vertical lines (see Fig. 47).

Curvature in vertical lines in the top portion of the picture is commonly called "hook." This curvature is particularly apparent on a test pattern, or a picture with distinct vertical lines, such as the sides of a door or folds in drapery. The curvature is normally in the form of a bow or a bend to the right in top portion of the picture.

The hook can be materially decreased by addition of a 12k-ohm, 20%, 1/2-watt, composition resistor (*R-198*) and a .005- μf ceramic capacitor (*C-180*) in the grid circuit of the horizontal oscillator control tube, *V-110A*. Refer to the schematic diagram shown here for location of these components. A further change which will improve the hook is the change of *C-142* from a .0047- μf to a .01- μf , 400-v paper type capacitor. However, this change reduces the horizontal sync hold-in range, and it is imperative that *C-146* and *C-149* be changed

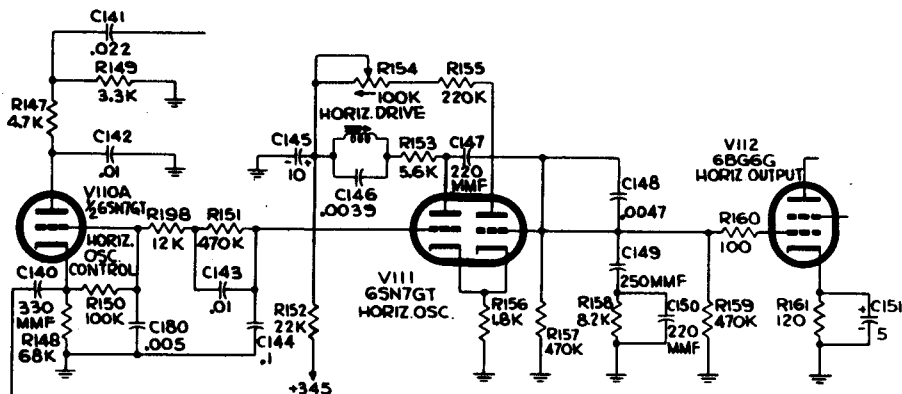

Fig. 47 — Hoffman

to zero temperature coefficient types as described under "Horizontal drift" for chassis 159 and 160 if the change of *C-142* is made.

HOFFMAN Chassis 159, 160
Improving horizontal sync pull-in range.

When tuning from station to station, or when the receiver is first turned on, there may be a momentary delay before the picture will pull into horizontal sync. To increase the pull-in range and improve the pull-in characteristics of the receiver, a modification has been made on all receivers produced after serial No. DO37401. The changes are:

1. *C-143* (in the grid circuit of *V-110A*) is changed from .0047 to .01 μf , 20%, 200 v, part No. 4142.

2. *C-141* (connected to one side of the horizontal-size coil) is changed from .0047 to .002 μf , 20%, 1,000 v, part No. 4135.

An additional result of changing *C-141* is that a different phasing relationship is obtained between the horizontal-sweep voltage and the sync signals in the horizontal oscillator control tube. This causes the picture to start at a point further to the right and allows for easier centering without neck shadows. When this change is made, check the values of *R-147*, *R-149*, and *C-140* to make sure they are the correct values as shown on the schematic for chassis 159 and 160.

HOFFMAN Chassis 159, 160
Horizontal drift.

To aid in eliminating drift and to improve the long-time stability of the horizontal multivibrator, the

capacitor *C-149* (output of multivibrator), 250 μf , part No. 4086, must be a ceramic NPO (zero temperature coefficient). In sets produced prior to serial No. EO47496, *C-149* has been a GP type ceramic, with no rated temperature characteristic. In some instances, a 330- μf capacitor may be found as *C-149*. The 330- μf unit should be replaced with the proper 250- μf NPO ceramic. The capacitance 250 μf is critical, and no other value should be used. If a ceramic NPO condenser is not available, a silver mica type with a low temperature characteristic is suitable.

The change of *C-149* will eliminate most drift problems. However, further stabilization may be obtained by changing *C-146*, .0039- μf capacitor across the hold coil from its present ordinary mica type to a silver mica type with low temperature characteristic.

HOFFMAN Chassis 159, 160
Christmas-tree effect.

The Christmas-tree effect, with symptoms as described under "Regeneration in i-f amplifiers" for chassis 159, 160 appears on unused channels when no signal is present, such as when switching from channel to channel. In addition to evidences on the picture tube, the effect is characterized by loud frying or singing sound from the horizontal-output transformer. Although this singing causes no apparent harm, it is annoying and sound destructive. The primary cause of Christmas-tree effect is regeneration, and this should be eliminated on sets requiring wiring changes.

A second cause is excessive resistance. Set the drive control, *R-154*, at minimum in the horizontal-drive circuit. minimum resistance (maximum counterclockwise rotation). This position can be used when setting up the horizontal controls unless a vertical white bar appears in the center of the picture. In this case, the control can be set to eliminate the white bar. In some receivers, the potentiometer may be 250k ohms instead of the rated 100k ohms. Replace these 250k-ohm controls or shunt them with a fixed 220k-ohm resistor to bring the total resistance to the proper value.

A third possible cause is too high a capacitance value of *C-149* (output circuit of horizontal oscillator). Too much capacitance in this component tends to cause Christmas-tree effect and poor sync hold-in.

HOFFMAN Chassis 159, 160 **Reducing vertical size.**

The vertical output is sufficient to more than fill the entire tube screen. In some cases, particularly on the 159 chassis, the vertical-size control will not decrease the size of the picture sufficiently to have all of the picture appear on the tube. Increasing the value of *R-181* (in series with the size control) from 1.5 to 2.2 megs will reduce the vertical output to within normal range of the vertical-size control. In extreme cases it may be necessary to increase *R-181* to 3.3 megs.

A convenient arrangement for changing to 2.2 megs is to interchange the resistors *R-181* and *R-166* (in grid circuit of sync separator). This will result in values of 2.2 megs for *R-181* and 1.5 megs for *R-166*.

This change has been made on all sets produced after serial No. EO40192.

HOFFMAN Chassis 159, 160 **Horizontal sync instability.**

As an aid in stabilizing the horizontal sync, the following components are added or changed:

1. Capacitor *C-144* (.1- μ f, 20% 200v paper) is connected from the grid (pin 1) of the horizontal oscillator to ground.

2. Capacitor *C-179* (47- μ f, 20%, 500v ceramic or mica) is connected in parallel with *R-166*, from pin 1 of *V-115* to ground.

3. Resistor *R-148* (68k ohms, 20%, 1/2 watt) is connected between pin 3 of the horizontal oscillator control tube and ground.

4. Capacitor *C-143* in grid circuit of the control tube is changed to .01 μ f, 20%, 200 volts.

Sync instability in sets with the above, produced prior to serial No. DO34738, may be caused by the inversion of *C-144*. This capacitor is a molded phenolic, paper-dielectric type. It is imperative that the outside foil be connected to ground. If this capacitor is inverted, with the outside foil connected in the grid circuit, stray pulses will be picked up which cause severe instability. In construction of this capacitor, one of the leads has a solder bump located just outside the phenolic case. This lead is connected to the outside foil and must be connected to ground. Careful control of the polarity of this capacitor has been exercised in sets produced after serial No. DO34738. Leads should be kept short and the capacitor mounted close to the chassis.

HOFFMAN Chassis 159, 160
Adjacent-channel trap adjustments.

The adjacent-channel traps, *L-102* and *L-103*, may require adjustment to a different set of frequencies to give optimum operation in some locations. Alignment data shows 28.1 mc for *L-103* and 28.5 mc for *L-102*. Factory production is aligning to 27.6 mc for *L-103* and 28.1 mc for *L-102*. The frequency 27.6 mc represents the adjacent-channel carrier and more efficient trapping is obtained, particularly in fringe areas. Setting the traps to the lower frequencies tends to steepen the side of the i-f bandpass characteristic and may result in a sharper sound tuning characteristic.

In setting the adjacent-channel traps, two positions of the iron slug will produce resonance. The trap will be most effective if the slug is set in a position going into the electrical "bottom" of the coil. The electrical "bottom" is the grounded end of the winding. Physically, the "bottom" end is opposite from the end held in the chassis by the tinnerman nut. In practice, the slug may protrude out of the coil form by an amount of one or two threads. This slug position is most effective for either set of trap frequencies.

The trap settings materially affect the i-f alignment, so it is suggested that no adjustments be made on the traps unless complete realignment can be completed.

HOFFMAN Chassis 159, 160
Increasing life of high-voltage rectifier.

The chassis 159, with 14-inch picture tube, has a 4.7-ohm resistor in series with the 1X2, high-voltage

rectifier, filament. This resistor drops the filament operating temperature below the most desirable condition for long tube life. Reduce this resistor, *R-164*, to 2.2 ohms, 10%, 1/2 watt, part No. 4735.

The corresponding part in the 160 chassis should remain at 4.7 ohms. The reason for the difference between the two chassis is that the 14-inch tube requires less high voltage and horizontal sweep than the 16-inch tube. As a result, the 6BG6-G screen resistor, *R-162*, is 15k ohms on chassis 159, which reduces the drive to the horizontal-output transformer, *T-107*, and in turn reduces the available 1X2 filament voltage.

HOFFMAN Chassis 159, 160
Preventing failure of C-166.

The failure of *C-166*, vertical blanking coupling capacitor, (.005 μ f, part No. 4069) causes the brightness control to have no effect. Shorting of *C-166* places a constant positive voltage on pin 2 of the picture tube, and the screen remains lighted at all times. Replacement of the capacitor affords temporary correction, but the capacitor may fail again due to voltage spikes in the vertical-deflection circuit, temporary arcs in the picture tube, or shorting of *R-145* to ground.

This condition can be remedied permanently by physically and schematically interchanging the positions of *C-166* and *R-145* (1 meg, 1/2 watt). The two components form a series circuit, so that the operation of the receiver is not affected. However, the 1-meg *R-145* will protect *C-166* from voltage spikes. The two components should be interchanged whenever re-

placement of C-166 is necessary. This change has been made on all sets produced after serial No. DO37401.

HOFFMAN Chassis 159, 160

Forestalling heater-cathode breakdown in picture tube (see Fig. 48).

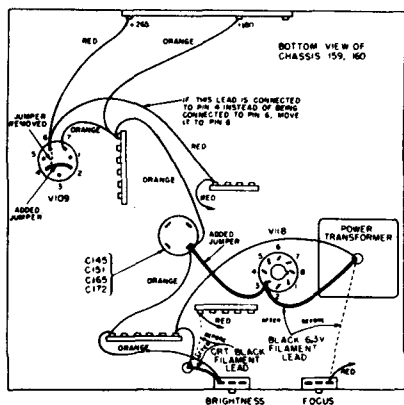

Dotted lines indicate wiring before change is made. Heavy black lines indicate wiring that is changed or added.

Fig. 48 — Hoffman

Field reports indicate that a number of chassis 159 and chassis 160 receivers are experiencing intermittent picture tube trouble as evidenced by loss of raster. This trouble occurs in receivers that use a picture tube that has an abnormally low heater-to-cathode breakdown potential characteristic. In order to provide a greater safety factor in the receiver, the picture-tube heater d-c potential should be lowered from the 265 volts originally used to 180 volts. The figure indicates the necessary change in wiring.

HOFFMAN Chassis 159, 160

Regeneration in i-f amplifiers.

Regeneration in the i-f amplifiers, particularly at low signal level where little agc bias is developed, may result from feedback through the B+ lines on sets produced prior to serial No. DO35142. Two effects may be produced, one when a station is tuned in and another on unused channels when no signal is present.

The effect on a picture is production of a vertical, 1/8 to 1/4 inch wide band, spaced about 1/4 inch from the left edge of the raster. The band contains variable width diagonal stripes, alternate dark and light, which produce a "barber pole" effect.

The effect when no signal is present, is known as "Christmas tree." The white raster, with brightness turned up, will appear with several variable width sections, giving it an appearance of a Christmas tree. In severe cases, the raster disintegrates into "layers" of bright horizontal lines filling approximately the center 50% of the raster area. The lines are accompanied by a loud singing of the horizontal-output transformer. This latter effect disappears when a station is tuned in.

The following changes can be made in the wiring layout of chassis 159 and 160 to aid in reducing regeneration. Schematically, no changes are made in the circuit.

1. Remove the coax lead running from the tuning-unit video output to coil L-101.

2. Replace connection with wire, dressing wire against chassis.

3. Remove two red +265-volt wires (in some sets these wires are orange) from the 80- μ f, 475-v, elec-

trolitic capacitor (shown as present *C-171* on schematic).

4. Remove orange +345-volt wire from the 80- μ f, 475-v, electrolytic capacitor (shown as present *C-170* on schematic). Remove one end of *R-193* (150 ohms) from same electrolytic.

5. Reconnect one +265-volt red wire (from *R-195*, focus control) to the electrolytic capacitor formerly occupied by +345-volt orange wire.

6. Reconnect orange +345-volt wire to electrolytic formerly occupied by two red wires.

7. Reconnect free lead of *R-193* to new position of +345-volt wire as in step 6 above.

The steps 3 through 7 are for the purpose of exchanging the physical locations of *C-170* and *C-171*. Schematically, no changes have been made.

8. Disconnect one blue wire (going to *R-197* voltage divider) from the +140-volt point at *C-173*.

9. Reconnect blue wire to +140-volt tie-point in sound i-f strip (junction of *R-102*, *R-104*).

10. Reconnect red wire (+265-volt lead from *R-196*, previously disconnected in step 3) to junction of pins 4 and 6 at tube socket of *V-109*, 6AU6, agc keyer.

If heater leads of *V-109* are connected directly to the tube socket, the following change should be made.

11. Remove *V-109* heater wires (black, twisted leads from power transformer) from tube socket pins. Leave all other wires in place. Connect one wire to +265-volt string at junction of *R-195*, *L-113*, on focus potentiometer. Connect other black wire to tie-point junction of brown

wires running to heater of cathode-ray tube and heater of *V-109*.

These changes have been made on all sets produced after serial No. DO35142.

On early production receivers, prior to serial No. CO23200, one additional change is required. A white wire, carrying agc voltage, runs along the front of the i-f strip, between the adjacent-channel traps, *L-102*, *L-103*, and the i-f amplifier tubes. This wire should be rerouted so that it lies outside the i-f strip, and against the main chassis, under the lip of the i-f strip subchassis.

To realize full benefit from the wiring changes to reduce regeneration, the chassis should be realigned after completion of the rewiring.

The metal bottom plate for the chassis may provide an additional feedback path in some cases, particularly in fringe areas where the signal is low and little agc bias is developed. This condition will be characterized and aggravated by the 3rd i-f stage being "hot" or regenerative. To alleviate this situation, a non-metallic bottom plate has been developed and is available on order under part No. 3735.

HOFFMAN

Chassis 170
through 176, 180, 183
through 187

Elimination of channel-5 tweet interference (see Fig. 49).

There are some receivers in the field that are troubled by a tunable herringbone interference which appears on channel 5 when a weak signal is being received. The interference is the beat note between the 3rd harmonic of the picture i-f frequency

($3 \times 26.1 \text{ mc} = 78.3 \text{ mc}$) and the channel 5 picture carrier (77.25 mc). Most receivers are driven by a reasonably strong signal so that enough agc bias is developed to make the i-f amplifiers insufficiently sensitive to pass the signal on to the video-amplifier stage. However, receivers in weak-signal areas or receivers using an indoor-type antenna in only fair-signal areas develop less agc bias, and the picture i-f amplifiers have sufficient gain to pass the beat note on to the video amplifier. Receivers that fall into the latter category may be made immune from tweet interference by the following field service change.

In 180-series chassis:

1. Obtain the following parts:
 - a. Adjustable tweet-coil assembly (part No. 5410).
 - b. Ceramic capacitor, $100 \mu\text{mf}$, N750 (part No. 4012).

2. Mount the coil assembly in the blank cut-out identified as "A" in part (A) of the figure. The assembly should be mounted with the screw shaft on top of the chassis.

3. Disconnect the yellow lead from pin 2 of the video amplifier and solder it and one lead of the $100\text{-}\mu\text{mf}$ ceramic capacitor to tie-lug 2 of the tweet coil.

4. Ground the other $100\text{-}\mu\text{mf}$ capacitor lead, cutting lead as short as is practicable.

5. Run a short jumper lead between tie-lug 1 of the tweet coil and pin 2 of the video amplifier.

6. Tune in channel 5 for best sound. If receiver is not being operated in a weak-signal area, simulate a weak signal by using an indoor antenna or a balanced H-type resistance pad.

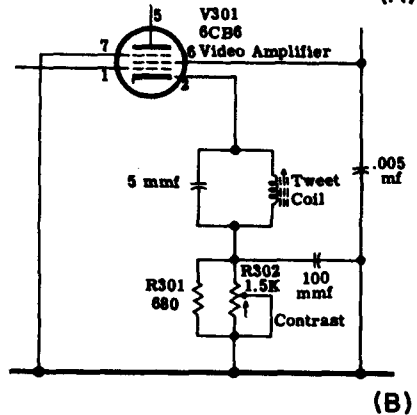
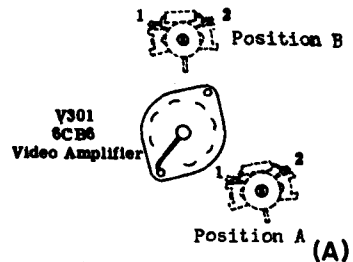

Fig. 49 — Hoffman

7. Couple 2-wire transmission line to yellow picture tube cathode lead for stronger 3rd harmonic signal by wrapping transmission line about yellow lead.

8. Tune tweet coil for minimum interference on picture-tube screen.

In 170-series chassis with 4.5-mc beat trap:

Follow steps 1 through 8 above, but add a $.005\text{-}\mu\text{f}$ ceramic capacitor, part No. 4029, between pin 6 of the video amplifier and ground.

In 170-series chassis without 4.5-mc beat trap:

Follow instructions above with one exception. Mount tweet coil in blank hole identified as position "B" in part (A) of the figure.

Since the problem is one related to signal strength of a particular loca-

tion, it is recommended that the change be made on an individual basis.

HOFFMAN

Chassis 170
through 176, 180, 183
through 187

Vertical roll.

The characteristic of this particular vertical-roll problem is that it is impossible to keep the picture locked in vertical sync for a single setting of the vertical-hold control. This condition is a result of the free-running frequency of the vertical oscillator increasing due to the tube characteristics of the 6BL7GT changing as the tube becomes warm. The remedy for the problem is to replace the 6BL7GT with a new type, a 6BX7GT, which is a direct replacement from a pin numbering standpoint. However, in a few instances it will be necessary to make a wiring change when substituting a 6BX7GT for a 6BL7GT.

In instances where insufficient vertical size with bottom compression exists after making the tube substitution, check whether the vertical-size control is connected to the boost-voltage buss. The boost-voltage buss may be identified by the yellow lead of the deflection yoke or the red lead of the width coil. The boost-voltage measures approximately 600 volts. If the control is not connected to boost, make the necessary change. If the size control is connected to the boost-voltage buss check the value of *R-604*, the 3.3-meg resistor which is connected in series with the size control. A 2.7-meg value may be used in these special cases of insufficient height. In a few instances folding at the top of the picture may occur after the tube

substitution is made. Increasing the value of the peaking resistor, *R-185* in 170-series chassis and *R-606* in 180-series chassis by approximately 2k ohms will eliminate the folding.

HOFFMAN

Chassis 170
through 176, 180, 183
through 187

Improved vertical stability in fringe areas.

Some of the receivers of the chassis types given for this note encounter vertical-hold trouble when they operate in fringe areas. Where extremely weak signals are present, the symptom appears as a continual vertical roll of the picture. In weak-signal areas the symptom appears when an occasional frame or two vertical slip or jump every time a relatively strong noise signal is encountered.

The vertical hold stability may be improved so that the trouble may be prevented or reduced in effect, depending upon the signal strength that exists.

1. Change *R-303* from 47k to 10k. This resistor is in the coupling circuit between the video amplifier and the 1st sync separator.

2. Change *C-501* from 220 μf to .001 μf . This capacitor is in the coupling circuit between the video amplifier and the 1st sync separator.

3. Change *R-501* from 10 meg to 1.5 meg. This is the grid resistor of the 1st sync separator.

4. Add a 47- μf capacitor between pin 1 of *V-501* and ground.

These changes rescind a portion of recommended changes which appear under "Improved picture definition" for chassis 170 through 176. These

latest revisions described above, change the four components back to the original earlier 170 series component values. This does reintroduce a reduction in definition which takes the form of smear, but the noise signal encountered in fringe areas masks this smear so that better operation is gained from a practical point of view.

Another change that is suggested for receivers operating in extreme fringe areas is to raise the B- supply voltage of the 1st sync separator, V-501, from +140 volts to +195 volts. This will result in a stronger sync signal for controlling the vertical oscillator.

It is emphasized that these changes are for fringe-area receivers. They are not applicable to receivers which operate in normal or strong-signal areas. Were the four components to be changed in normal area receivers, a smear effect would result as mentioned above. Were the B- supply voltage of the 1st sync separator to be raised in normal-area receivers, the sync signal would be improperly separated, causing the horizontal afc system to operate on the leading edge of the horizontal-sync pedestal at high-contrast levels. At low-contrast levels the operation would be off the sync pulses as is normally the case. Therefore, a change in contrast level from low to high or high to low would cause a horizontal phase shift of the picture. For these reasons the recommended changes must be made on an individual basis rather than on a production basis.

HOFFMAN

Chassis 170
through 176, 180

**Mounting modification of 3rd i-f
transformer shield (see Fig. 50).**

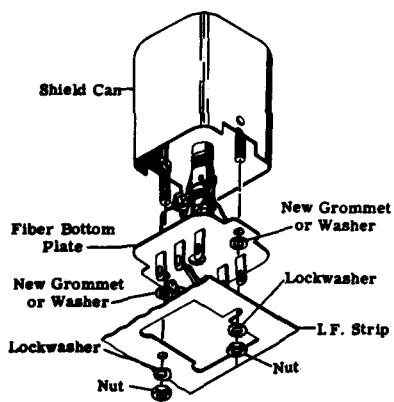

Fig. 50 — Hoffman

The following modification is suggested as a means of eliminating the necessity for disconnecting leads soldered to the lugs of the can assembly which houses the crystal video detector when replacement of the crystal or other component inside the can is required. The change can be made at such times as removal of the shield has been necessitated by failure of an internal part.

Upon completion of the repair to the assembly, the two nuts that are used to hold the fibre bottom plate to the shield can should be replaced by small rubber grommets or small washers of comparable size and thickness. Proceed with the remaining installation as previously performed. The two remaining nuts are adequate for holding the assembly and shield can firmly in place. When the two remaining nuts are removed henceforth, the can may be lifted from the assembly, the assembly being held in position by the wire leads soldered to its tie lugs.

Focusing of various picture tubes.

The picture tubes of various manufacturers require slightly different values of focus-coil current to provide the proper field strength for correct focusing of the electron beam. The current requirement of the original factory-installed picture tube is provided for by appropriate circuit modifications. The information given below is intended to aid the serviceman in obtaining the correct focus current when replacement of the original picture tube is necessary.

After replacing a picture tube, note whether the picture tube goes through focus within the range of the focus control. If the point of focus cannot be reached, or if the point is at the extreme end of the focus-control potentiometer, one of the following corrective measures given below is recommended.

1. If focus is reached or approached at the extreme clockwise position (minimum resistance) of the focus control, less focus-coil current is required. To accomplish this, shunt the coil with a resistor having a value from about 2,500 to 5,000 ohms with a power rating of 4 watts or more.

2. If focus is reached or approached at the extreme counterclockwise position (maximum resistance) of the focus control, more focus-coil current is required. To accomplish this, remove the 5,000-ohm shunt resistor from across the focus coil.

Removing 4.5-mc beat interference (see Fig. 51).

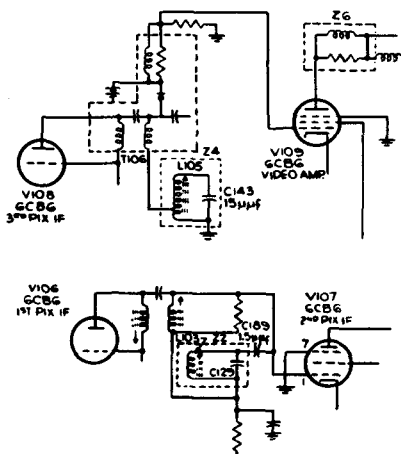

Fig. 51 — Hoffman

Some receivers are being troubled by excess 4.5-mc beat interference and sound in the picture. This unwanted situation makes it impossible to obtain a clear picture when the tuner is adjusted correctly for best sound. The difficulty may be eliminated by increasing the 21.6-mc trappage.

The additional 21.6-mc trap is obtained by converting Z-4, at present one of the two 27.6-mc adjacent channel sound traps. Z-4 is converted by increasing the capacitance in the parallel tuned circuit to 15 μ f. This is accomplished by shunting C-143 with an additional 5- μ f capacitor and peaking the converted trap to 21.6 mc.

Conversion of Z-4 to 21.6 mc results in less 27.6-mc trappage, so the connections on Z-2, the other adjacent channel sound trap must be changed to provide the additional trappage. To alter Z-2, disconnect the bare lead from the tap on the trap inductance. The tap connection is the one that is not connected to either side

of the 10- $\mu\mu\text{f}$ parallel capacitor. Reconnect the bare lead to the trap lug that also has the 330-ohm resistor and .005- μf capacitor connected to it. Connect a 1.5- $\mu\mu\text{f}$ capacitor between pin 1 of the second video i-f amplifier, V-107, and the lug on the trap inductance to which only the parallel capacitor C-129 is connected, keeping the leads as short as possible. Peak Z-2 for 27.6 mc.

The additional 21.6-mc trappage has eliminated the need for the 4.5-mc trap, and later factory production has eliminated its usage. It is recommended that the slug for the 4.5-mc trap be removed in all sets that there will be no possibility of this trap causing a dip in high-frequency response should it be misadjusted below 4.5 mc toward the high frequency end of the video response.

These changes have been made on all sets produced after serial No. HO69463.

There are several hundred sets with serial numbers lower than the given number which also incorporate the change. However, in these sets the 4.5-mc trap is present, but the slug has been removed.

HOFFMAN

Chassis 170
through 176

Improved video i-f bandpass characteristic (see Fig. 52).

In order to simplify the alignment procedure and provide a more nearly ideal video i-f bandpass characteristic, several changes may be made. The changes result in an approximately flat-topped i-f response curve by introducing more resistance loading into the first two video i-f transformers and by decreasing the coupling in the second video i-f

transformer. The loss in gain brought about by these changes is more than balanced by eliminating the by-pass portion of the cathode resistance in the first two video i-f stages. The resulting decrease in bias in no way causes the operating ratings of the tubes to be exceeded.

1. Change R-117 and R-122, grid resistors of the 1st and 2nd video i-f amplifiers, from 3,900 ohms to 3,300 ohms.

2. R-120 and C-126 in the 1st video i-f cathode circuit and R-126 and C-132 in the 2nd video i-f cathode circuit are not used.

3. R-119, the cathode resistor of the 1st video i-f amplifier is reduced from 47 ohms to 39 ohms.

4. C-133, interstage coupling capacitor between 2nd and 3rd video i-f amplifiers is reduced from 1.5 $\mu\mu\text{f}$ to 1.2 $\mu\mu\text{f}$.

The wiring of the two 3.3-k resistors and the 1.2- $\mu\mu\text{f}$ capacitor should duplicate the old components, regarding position and lead length. However, the new R-119 resistor and previous R-125 resistor should be returned to the suppressor grid ground point rather than returning the resistors to the grounded tie lugs of the tie-point strips. The latter connection would introduce unwanted inductance into the i-f circuits.

These changes have been made on all sets produced after serial No. G067626.

Note: R-117 should be reduced to 1.8 k in those chassis which employ the alternate adjacent channel sound trap. This alternate trap may be easily identified by ceramic trimmer capacitor mounted on the lip of the i-f subchassis near the 1st video i-f stage.

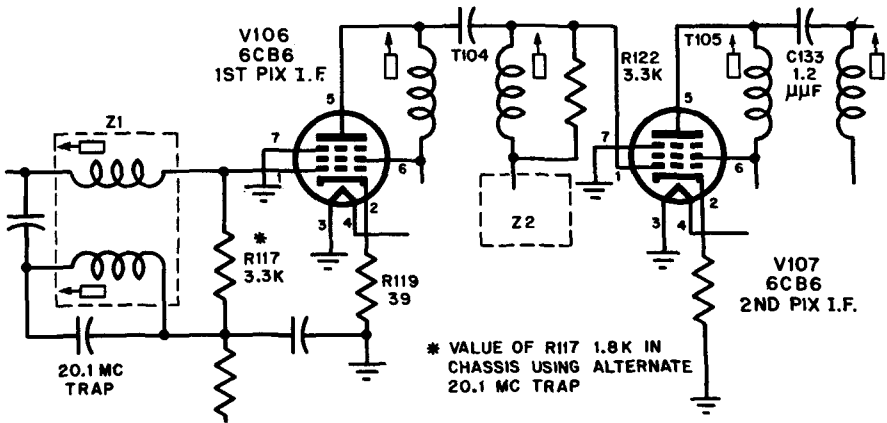

Fig. 52 — Hoffman

HOFFMAN Chassis 170 through 176
Eliminating Christmas-tree effect.

There are some receivers in the field that are troubled by Christmas-tree effect (see "Regeneration in i-f amplifiers") under certain operating conditions, such as occur during between-channel tuning or tuning to one particular channel. This condition may be remedied by reducing the resistance value of R-157, the 220-k resistor that is in series with the horizontal-drive potentiometer. This change has been made on all sets produced after serial No. G067626.

HOFFMAN Chassis 170 through 176
Dark shading at top of picture (see Fig. 53).

In order to eliminate dark shading at the upper portion of the picture that occurs on some receivers at low contrast settings, the following changes are recommended:

For sets containing the smear change (see "Reduction of picture

smear" for chassis 170, 171, 173, 175), remove C-185 and reduce the resistance value of R-143 to 100k ohms. Change C-146 to a higher voltage rating (.0047 μf at 1,000 volts) and rewire as indicated in figure. Dotted lines indicate wiring and components before this change was made. Heavy black lines indicate wiring and components changed.

For sets not containing the smear change, move C-146 leads to other

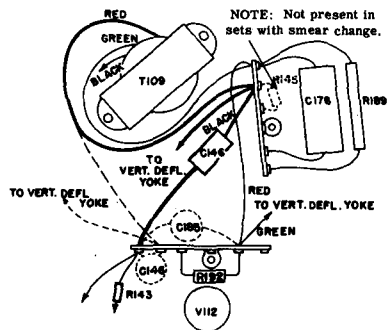

Fig. 53 — Hoffman

side of *R-145*, eliminating *R-145* from the circuit. Also, reduce resistance value of *R-143* to 100k ohms.

This change has been made on all sets produced after serial No. GO67626.

Note: *C-146* and *C-185* shown in the figure may have their "C" numbers erroneously interchanged in the schematic diagram in the service notes. This must be kept in mind if reference is made to this schematic concerning the change described above.

HOFFMAN Chassis 170
through 176

Elimination of smear.

Smear, as exemplified on the screen by trailing shades from black toward white after large objects, and white toward black after large white objects, and a general fuzzy appearance throughout the picture, is still present in some sets incorporating the smear change covered under "Reduction of picture smear" for chassis 170, 171, 173, 175. The remaining smear is caused by insufficient low-frequency response of the video amplifier, and it may be eliminated by an increase in low-frequency response. To accomplish this, the coupling capacitor between the video amplifier and the picture tube should be increased in value. To do this, change *C-145* (.005 μ f at 500 volts) to a .22 μ f at 200 volts capacitor.

This change has been made on all sets produced after serial No. GO67626.

HOFFMAN Chassis 170
through 176

Contrast improvement.

Field reports have indicated that more picture contrast is desirable at high-level settings of the contrast control. The condition shows up as a washed-out appearance of the picture. The affect has been due to the linear relationship between the increase in contrast and the increase in brightness. In order to obtain a picture that appears to have more contrast at high-contrast levels, the relationship can be made nonlinear by the following change. Increase the resistance value of *R-141* (in the cathode circuit of the picture tube) from 100,000 ohms to 330,000 ohms. When this has been done the picture brightness will increase at a slower rate than the rate of increase in picture contrast.

This change has been made on all sets produced after serial No. GO67626.

HOFFMAN Chassis 170
through 176

Changing range of contrast control.

All later production chassis have a 680-ohm, 1/2-watt resistor connected in shunt across the contrast potentiometer. The physical location of the new resistor is from pin 2 of *V-109*, the video amplifier, to ground. The maximum resistance in the cathode circuit of the video amplifier is lowered, and the minimum contrast level previously obtained is raised. This means that the seldom used lower third of the contrast range is dispensed with, and the more useful range that remains is spread out over a greater scale.

It is important to note that the recommendations for setting the brightness control are now different.

The recommended procedure for setting the brightness control is to set the control for medium brightness at minimum contrast setting. This will produce a picture with average background characteristics at about three-quarters contrast setting. For individual tastes that vary from this recommendation, the brightness control may be set so that it is most pleasing to the observer.

HOFFMAN

Chassis 170
through 176

Improved picture definition (see Fig. 54).

Closely associated with the smear effect as far as picture appearance is concerned, is the general lack of contrast which shows up in the picture

as a reduction of fine detail. This effect is caused by a falling off of the high-frequency end of video response in the video-amplifier circuit. The response may be improved by making the following changes which may be identified in the figure.

1. Remove *R-139* (47,000-ohm resistor connected to the grid of the agc keyer tube) and replace it with a short piece of hook-up wire. It is suggested that the leads of *R-139* be kept as long as possible during its removal so that it may be used to replace *R-138*.

2. Remove *R-138* (10,000-ohm resistor between the video amplifier and the sync separator) and connect a 47-k resistor between the junction of *L-106*, *L-107* (plate circuit of video amplifier) and the tie lug

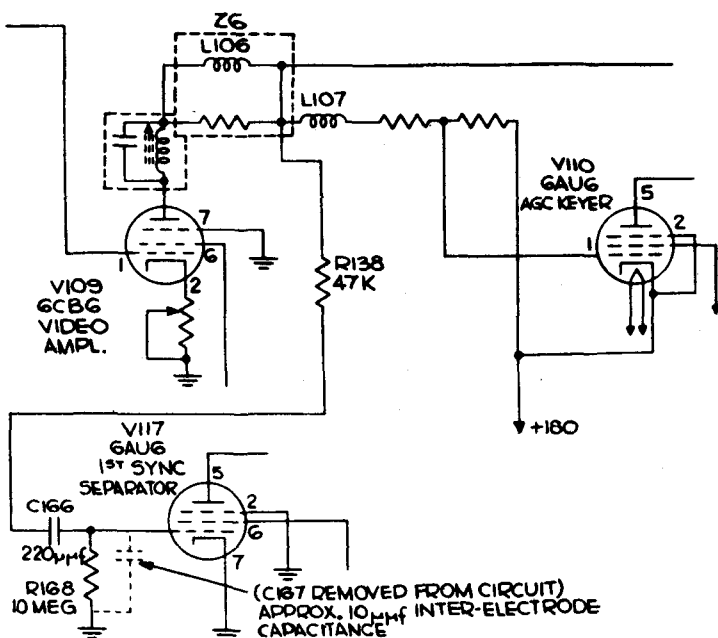

Fig. 54 — Hoffman

previously used for connecting *R-138* to *C-166*.

3. Change *C-166* (coupling capacitor to the 1st sync separator) from .001- μ f to a 220- μ f ceramic capacitor.

4. Change *R-168* (grid circuit of 1st sync separator) from 1.5 meg to 10 meg.

5. Remove *C-167* from grid circuit of the 1st sync separator.

These changes will introduce less loading on the video amplifier without changing the noise immunity going into the 1st sync separator.

The changes have been made on all sets produced after serial No. HO70169.

HOFFMAN

Chassis 170,
171, 173, 175

Light vertical bars in raster.

A. .047- μ f, 400-volt capacitor is added across the vertical-deflection coils of the high-impedance yoke only. The purpose of this addition is to reduce light vertical bars in the raster due to internal deflection yoke coupling. Since this internal coupling varies among deflection yokes, only a relatively few sets contain yokes that give noticeable indication of these bars. Only those sets in the field that give evidence of these light vertical bars need be serviced regarding this addition. The change was added to all later production as an insurance measure. The physical location of the capacitor is under the chassis. One side is connected to the black vertical deflection coil lead. The other side is connected to a red plastic-covered jumper wire that is in turn connected to the green vertical deflection coil lead.

HOFFMAN

Chassis 170,
171, 173, 175

Beam modulation in horizontal-output tube.

A recent change in the internal structure of some 6BG6G horizontal-output tubes has brought about a condition of beam modulation in the 6BG6G. This condition shows up in the raster as a 120-cps horizontal wave of about a quarter inch peak-to-peak amplitude in extreme cases. This condition will be made negligible by changing the .047- μ f screen by-pass capacitor for the 6BG6G to a 4- μ f electrolytic or greater. Anything between 4 μ f and 20 μ f is recommended.

An alternate modification is as follows: *R-164* (screen resistor of the horizontal-output tube) is replaced by two 3.3k-ohm, 2-watt resistors in series. *R-154* (plate circuit of horizontal oscillator) is eliminated, and the junction of *C-153*, *L-109*, *C-154*, and *R-156* is connected to the screen of the 6BG6G.

HOFFMAN

Chassis 170,
171, 173, 175

Preventing heater-cathode breakdown in picture tubes.

An additional safety factor on the cathode-ray tube heater-cathode potential may be provided in the above listed chassis. This is accomplished by tying the picture tube filament to a +180-volt potential instead of the +265-volt potential formerly used.

The following wiring changes are made in order to achieve the above objective. At the agc keyer tube, *V-110*, the jumper between pins 4

and 6 is removed. The red (orange in some chassis) wire that formerly was connected to pin 4 of *V-110* is moved to pin 6 of *V-110* so that both red (and/or orange) wires are connected to the same pin. In some early receivers only the jumper need be removed since both wires are already connected to pin 6. A jumper is run between pins 2 and 4 of *V-110*. So far, then, the result has been to change the filament connection from the +265-volt string to the +180-volt string. This is necessary because the *V-110* filament shares its filament winding with the picture tube, and the B+ string leads included in the wiring change serve the dual function of completing the filament circuit of these two tubes and of providing the correct B+ potential to the filament.

Continuing the wiring change detail, the transformer filament lead that formerly connected to the +265-volt side of the focus control, *R-196*, is moved to pin 3 of the 5U4, *V-116*. Formerly, pin 3, had not been used. An additional orange wire 8 inches long is connected to this same pin 3 and to the tie lug on *C-183*. The black picture tube filament lead is removed from the +265-volt string tie lug and wired to the +180-volt side of the brightness control (*R-142*). The final result is to change the B+ leads that make up part of the filament circuit shared by the picture tube and agc keyer tube so that the filament potential of the picture tube is brought closer to its cathode potential. In this manner the safety factor on the picture tube heater-cathode potential is increased. Later production runs of the above chassis already include the above changes.

HOFFMAN

Chassis 170,
171, 173, 175

Improved sound-tuning characteristic.

A change involving the audio i-f section of the tv receiver is made in order to make the point of optimum sound reproduction less critical when the head end is tuned. This objective is accomplished by broadening the sound i-f bandpass. Therefore, just as the broad bandpass of the video i-f stages makes it possible for the r-f oscillator to be detuned slightly, giving a higher or lower center i-f frequency without serious changes in picture reproduction, so the broader bandpass of the sound i-f stages permits a less critical tuning of the r-f oscillator.

In order to increase the bandpass, the following circuit and part changes are made:

1. Reduce the value of *C-103* and *C-109*, screen bypass capacitor for *V-101* and *V-102*, from .005 μf to 1,500 μf .
2. Remove *C-108* from the circuit.

HOFFMAN

Chassis 170,
171, 173, 175

Reduction of picture smear (see Fig. 55).

A change concerning the retrace line elimination circuit is made in order to reduce picture smear present when the picture tube draws grid current. A study of the schematic diagram will reveal that retrace-line elimination circuit can act as a grid-leak biasing circuit for the picture-tube grid. When the grid draws grid current, as it will when the cathode is driven by relatively high negative peaks (high contrast levels), a nega-

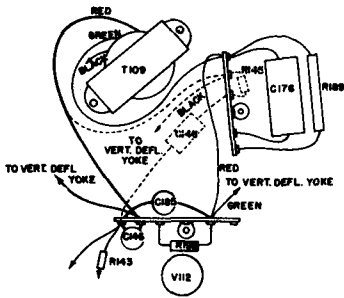

Fig. 55 — Hoffman

tive bias is produced which tends to bring the picture grid to its cut-off potential. This negative bias remains on the grid until it has had time to leak off via the RC path of the circuits involved. By reducing the RC time constant of the effective grid leak, the grid is not held near cut-off for so long a time, relatively speaking, and the faster recovery makes it possible for the grid to better follow the transmitted video information.

The RC time constant is reduced by making the following circuit and part changes:

1. Delete *R-145* (1-meg resistor), which is in series with *C-146*.
2. Change coupling capacitor *C-146* from .0047 μf at 1,000 volts to .005 μf at 500 volts.
3. Add a .005- μf capacitor to complete the capacitance voltage divider.

The diagram shown indicates the original wiring by means of dotted lines and the rewiring by means of heavy black lines.

HOFFMAN

Chassis 183

Vertical picture roll.

There are some receivers in the field that may give evidence of a vertical-roll problem. The symptom is a downward roll of the picture after

the receiver has warmed up. The remedy for this condition is to replace *R-601* in the blocking oscillator grid circuit with a new resistor of the same specification: 1 meg, 1/2 watt, 10% tolerance, composition type.

HOFFMAN

Chassis 187,
187B, 187C

Vertical jitter.

When the hot horizontal-deflection coil lead lies close to the vertical-deflection tube, the 6BL7GT, it couples horizontal-voltage pulses into the vertical system causing the triggering of the vertical-blocking oscillator to become abnormal. This condition results in a rapid vertical jitter of the picture. The remedy for this problem is to dress the red deflection yoke lead away from the 6BL7GT.

HOFFMAN

Chassis 187,
187B, 187C

Picture smear.

Closely related to the problem mentioned under "Vertical Jitter" for chassis 187, 187B, 187C is picture smear. If the red deflection yoke lead is dressed too close to the picture tube cathode lead, the yellow lead connected to the picture-tube socket, horizontal-voltage pulses will be coupled to the picture-tube cathode, causing the picture tube to draw grid current on the negative portion of the voltage pulse. There is also the possibility of the horizontal pulse reaching the sync circuits via the picture tube cathode lead and RC circuit between this lead and the 1st sync separator. If the coupling is severe enough a condition of "Christmas tree" is apt to occur. The remedy is to dress the

yellow cathode lead and red yoke lead away from one another, taking care not to dress the red yoke lead too near the 6BL7GT.

HOFFMAN Chassis 187, 187B
Increasing life of 150-ma fuse (see Fig. 56).

In some of the earlier receivers the 150-ma *Slo-blo* fuse has a tendency to blow on surges of current drawn through it. The figure shows how the fuse circuit is changed so as to eliminate the condition.

1. Capacitor *C-720* (.005- μ f Hi-K ceramic) is changed to a .0047- μ f, 600-volt molded unit (part No. 4128) in order to obtain a higher voltage rating.

2. Capacitor *C-721* (.22- μ f, 20%, 400-volt molded, part No. 14103) is added in shunt across the 150-ma fuse.

It is recommended that the revision be incorporated in these early receivers at such time as servicing is

contemplated as a precautionary measure against future fuse trouble.

HOFFMAN Chassis 187, 187B
Improving adjacent-channel trappage.

If adjacent-channel interference is a definite problem in the area in which the receiver is located, proceed as follows: The picture i-f stages must be realigned after these changes.

1. Change *R-202* (grid circuit of 1st picture i-f) from 4,300 ohms to 3,300 ohms, 1/2 watt, 5% (part No. 4648).

2. Change *R-213* (plate circuit of 3rd picture i-f) from 2,700 ohms to 2,200 ohms, 1/2 watt, 5% (part No. 24525).

3. Change *C-206* (grid circuit of 2nd picture i-f) from 1.5 μ f to 2.2 μ f, 500 volts, 10% ceramic (part No. 4069).

4. Change *C-221* (in cathode circuit of video detector) from 1.5 μ f to 4.7 μ f, 500 volts, 10% ceramic (part No. 4081).

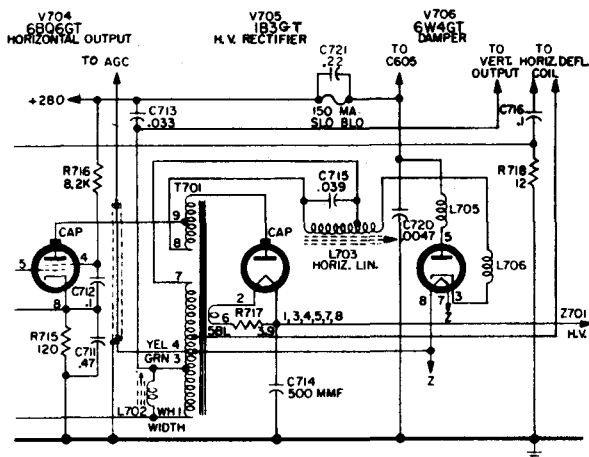

Fig. 56 — Hoffman

5. Delete C-223, 3.3- μf capacitor in cathode circuit of video detector.

6. Remove C-222 ($2 \times .004\text{-}\mu\text{f}$ capacitor) in 4th picture i-f and replace with two separate .005- μf Hi-K ceramic capacitors (part No. 4029).

HOFFMAN Mark IV chassis
Vertical roll (see Fig. 57).

Extensive tests in the factory indicate that the 6BL7 vertical tube is critical in that some tubes cause the picture to roll vertically during the warm-up period. Rather than hand pick 6BL7 tubes for the vertical circuit, it is suggested that the vertical-hold range be increased to mask any possible drift of the 6BL7 tube. This can be done as follows:

1. Replace R-502 (now 12 k) with a 33-k resistor ($\frac{1}{2}$ watt).
2. Replace R-503 (now 100 k) with an 82-k resistor ($\frac{1}{2}$ watt).
3. Jumper the .004- μf capacitor between the plate of V-502 (2nd sync) and the molded integrator block. This takes the .004- μf capacitor out of the circuit and extends the vertical-hold range. The changing of R-502 to 33 k and R-503 to 82 k also extends the vertical-hold range.

Later Mark IV chassis are being modified as detailed above. These chassis may be identified by a black "X" just below the a-c interlock plug on the rear of the chassis.

HOFFMAN Models with RF-1 head end
Noise in head ends.

Noise in RF-1 head ends (RCA head end, Hoffman part No. T9501) may be caused by the oscillator adjustment screws for channel 7 to 12 contacting the metal eyelets in the switch deck.

HOFFMAN Models with RF-2 head end
Noise in head ends.

If noise is present in the RF-2 head end (Sarkes Tarzian head end, Hoffman part No. T9514), proceed as follows:

1. Make certain that all four nuts in the rotary switch assembly are tight.
2. If the noise is particularly apparent when the fine-tuning control is rotated, check for the presence of small brass particles in the fine tuning capacitor tube. It may be necessary to tap the tube lightly to

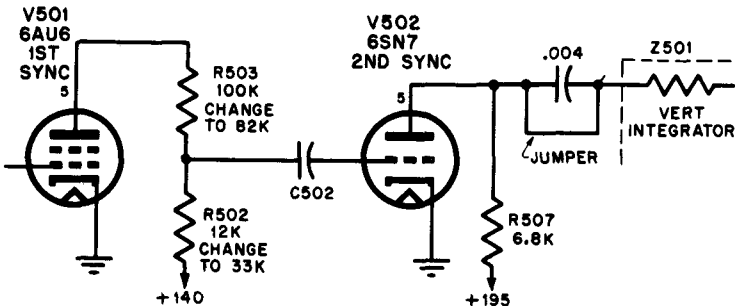

Fig. 57 — Hoffman

make a positive check for this condition.

If particles are present in the tube, do the following:

1. Remove the complete head-end unit. See schematic diagram in service notes for lead connections.

2. Disconnect the two ribbon leads of the fine tuning capacitor tube from pins 5 and 6 at the 6J6 tube socket, being careful not to break or shorten the leads.

3. Remove the snap-ring retainer at the front end of the station-selector shaft.

4. Mark the angular position of the fine tuning drive wheel on its shaft and loosen the two #4 set screws on the hub of this wheel.

5. Slide off the fine tuning control shaft and drive wheel together.

6. Mark the angular position of the threaded fine-tuning shaft and of the capacitor tube.

7. Remove the two lock nuts on the front end of the fine tuning capacitor tube.

8. Remove the fine tuning capacitor tube.

9. Remove the brass slug from the tube and clean both tube and slug with carbon tetrachloride.

10. Reassemble the head end, observing the following:

- a. Be sure to install the fine tuning capacitor tube, brass slug and drive wheel in the same relative angular position as they originally had.

- b. Do not set the two #4 set screws in the fine tuning drive wheel so tight that they damage the threads on the shaft. A light setting is adequate to drive the shaft.

11. Check the fine-tuning adjustment on all available channels.

HOFFMAN

Models with
RF-3 head end

Noise in head ends.

If noise is present in the RF-3 head end (Standard Coil head end, Hoffman part No. T9513), remove the turret assembly as follows:

1. Remove the shaft bushing on the front-chassis apron.

2. Remove the retainer spring at the back end of RF-3 chassis.

3. Remove the fine tuning stop screw located immediately to the right of the station-selector shaft, and the front retainer spring and plate.

4. The turret may now be removed from the bottom of the unit. Note: The roller will drop out the spring stop arm as the turret is removed.

With the turret assembly removed:

1. Clean all contact points with carbon tetrachloride and coat with a light film of *Lubriplate*.

2. Remove the fine-tuning disc and shaft and clean any oil or grease from both sides of the disc.

3. Polish the surface of the spring-stop roller with fine emery or crocus cloth.

4. Check the pressure of the coil holding springs at both ends of the turret assembly. Note: If it is necessary to bend these springs to obtain more pressure, be sure to maintain clearance between the front springs and the rear plate of the fine-tuning capacitor.

5. Check the spring pressure on the stationary contacts.

After the above procedure, reassemble the turret in the chassis. Check the seating of the shield can on T-25 against the chassis. If it does not seat firmly, insert a layer of phenolic sheet or insulating cambric

under the can so that it is rigid when in position.

HOFFMAN Chassis with turret tuners RF-3 through RF-6
Tunable modulation hum (see Fig. 58).

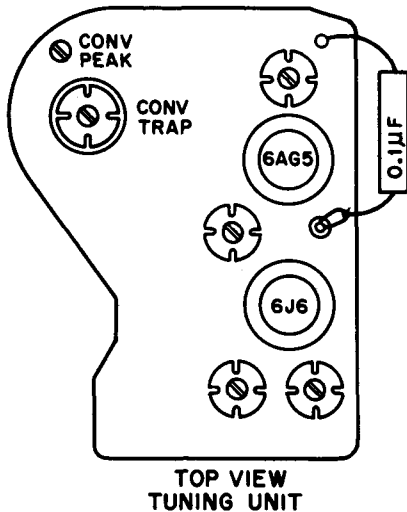

Fig. 58 — Hoffman

A low-frequency hum that is tunable with the fine-tuning control has been observed in a number of sets. The hum is at its loudest point when the sound is properly tuned in, and has been observed primarily on the channels where a strong signal is present. This hum can be reduced by removing one of the antenna leads, thereby reducing the signal.

There are three remedies that have been used in field service. The first, or capacitor method, is recommended. The second and third have disadvantages and should be used only when conditions warrant.

1. Solder a 0.1- μ f paper tubular bypass capacitor (voltage rating un-

important) from the test loop (see diagram) to ground on the tuning-unit body. Do not ground to the main chassis. The end of the capacitor marked "foil" is to be used for the grounded end.

2. A second method is to solder a 5,000-ohm, 1/2-watt composition resistor in place of the 0.1- μ f capacitor. This method reduces the sensitivity of the tuning unit and also decreases the bias on the 6J6 converter grid, allowing greater plate current flow with resultant increased heating.

3. A third method is to ground the test loop directly. This materially decreases sensitivity in addition to increasing current, and should not be used except in very pronounced hum cases and where very strong signals are available.

HOFFMAN All 10-, 12-, 16-, and 19-inch chassis
Lead-dress precautions.

In the 10 and 12-inch chassis—

The filament leads to the 1B3GT rectifier from the high-voltage transformer may lie in a position near the h-v button, terminal 3, of the h-v transformer. Pulse voltages appearing at terminal 3 will break down the insulation of the wires and result in arcing and other damage. The filament leads should be dressed down and away from the h-v transformer, directly as possible to the 1B3GT tube socket. These leads are heavy gauge solid copper conductors covered with a translucent vinyl insulation that may easily be identified.

The red insulated wire connecting pin 2 (filament) of the 1B3 to the h-v end of C-170, the 500- μ f h-v capacitor is suspended between the tube

socket pin and a solder lug attached to the capacitor. This wire should be dressed downward in a loop, away from the lower h-v button, terminal 3, of the h-v transformer. Arcing or burning of the insulation may occur if this wire comes in contact with the h-v button.

The lead from terminal 3 of the transformer to the plate cap of the 1B3GT is white with red tracer wire. In past production, this wire has been threaded through a small hole in the h-v transformer terminal board insulation at a point immediately adjacent to the terminal 3 corona button. The wire was then dressed upward, looping over to the tube cap of the 1B3GT. In this position the wire can come in contact with terminal 2 of the h-v transformer which is directly above terminal 3. Pulse voltages will break down the insulation on the wire with resulting arcing and damage to the wax impregnated terminal board. The remedy for this condition is to clip loose the plate cap connector and pull the wire back through the small hole in the terminal board adjacent to terminal 3. The wire can then be shortened and reconnected directly to the plate cap connector. The lead dress will be more direct and will not cross over the corona button of terminal 2.

The lead from terminal 2 to the 6BG6G tube cap should be dressed up and over to the tube cap as directly as possible. This lead may tend to lay over toward the metal side of the cage or down on the top connection to C-170, the 500- $\mu\mu\text{f}$ capacitor. Care should be exercised to dress this lead clear from all other parts, including the top of the cage.

On many sets a .05- μf capacitor is connected between terminals 5 and 6 of the h-v transformer to produce additional sweep width. It is important that this capacitor is mounted on the "outside" of the transformer such as near the iron frame of the transformer. Some instances have been observed where the capacitor was mounted "inside" adjacent to the h-v winding of the transformer. In this case, arcing will occur from the h-v winding to the capacitor which would tend to ignite the impregnation of the capacitor or h-v winding. Placement of this capacitor should be checked whenever the h-v cage is opened.

In the 16-inch and 19-inch chassis:

The vertical-output circuit contains a possible source of trouble. A few cases of failure of the electrolytic capacitor C-147B, has occurred. Shorting of this capacitor immediately burns out the 1,000-ohm, $\frac{1}{2}$ -watt plate voltage dropping resistor, R-170, in the vertical-output circuit. All wires should be dressed away from R-170 to avoid any further damage if this resistor should burn out. Specifically, the red lead to the vertical-output transformer should be dressed down against the chassis, away from the resistor. This source of trouble is a consideration particularly in any unfused receiver.

In the main chassis of all models:

The cathode-bias circuit of the 6BG6G horizontal-output tube contains a .1- μf capacitor and a 100-ohm, 2-watt resistor. These two components should be physically separated so as to provide heat insulation and circulation of air. In some instances, the leads of the two components have been twisted together so that the parts

are held tightly together. Undesirable heating of the capacitor's wax coating will occur under this condition. Check these components for physical separation.

All of the above precautions have been carried out in receivers of recent manufacture. These precautions should be observed when any critical parts replacement is made or when servicing receivers for other reasons.

HOFFMAN Chassis with
16-inch metal picture tubes
**High-voltage arcing around
picture-tube neck (see Fig. 59).**

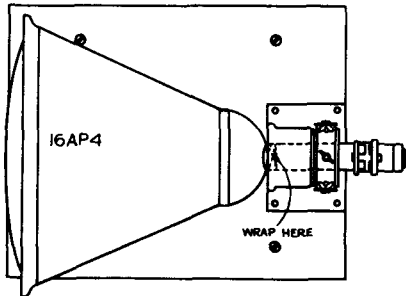

Fig. 59 — Hoffman

An arcing or sizzling sound may originate in the vicinity of the deflection-yoke assembly. In many cases this will also cause crackling noise in the sound channel and white or black splashes in the picture. This is caused by leakage of the high voltage from the metal cone across the insulating portion which allows arcing through the vinylite insulation and dust cover to the deflection coils.

To remedy, proceed as follows:

1. Loosen wing nuts on deflection yoke and pull deflection coil assembly back from the cone of the 16-inch tube, towards the focus coil.

2. Wrap two or three turns of vinylite tape around the base of the tube cone where it contacts the deflection coils.

3. Replace the deflection-coil assembly.

HOFFMAN

All chassis
with signal-keyed agc

Overloading of i-f amplifiers in strong-signal areas.

Quivering of the picture due to partial loss of both vertical- and horizontal-sync pulses has been observed in strong-signal areas. This occurs when a strong signal overloads the video i-f amplifiers and a limiting action occurs which clips the sync pulses. An increase in the agc action, which will produce more agc bias with strong signals, can be accomplished by decreasing the delay bias voltage on the agc diode. This delay-bias voltage is derived from the plate, pin 2 of *V-113A*, 2nd sync separator.

Reference to the circuit diagram will show that a 10k-ohm plate stabilizing resistor, *R-150*, is connected from pin 2 to ground. A smaller diode-delay bias can be obtained by effectively tapping down on this resistor. *R-150* at present is a 10k-ohm, 10%, 1/2-watt composition resistor. Remove this resistor from the circuit and replace with two 4,700-ohm, 1/2-watt, 10% composition resistors in series. The junction of the two new resistors provides a center-tap for connection of the delay-bias lead, a green wire from pin 5 of *V-110*. This green wire is at present connected to pin 2 of *V-113*.

This modification can be made on any receiver produced with signal-

keyed agc, and will aid materially in the stabilizing of picture sync in strong-signal areas. Factory modification has been accomplished on all sets produced after serial No. J921278.

HOFFMAN All chassis
Elimination of noisy volume control.

Field reports have indicated that there have been some cases of a condition of noisy volume control. Replacement of the volume control, *R-110*, has been only a short-term cure. This condition may be removed by inserting a .0047- μ f capacitor between the volume potentiometer, *R-110*, and the 15k-ohm resistor, *R-106*, connected to the volume potentiometer. The voltage rating of the capacitor should be 200 volts or greater.

HOFFMAN All chassis
Noise in head ends.

Crackling, snapping or other unpleasant noises may be heard when the station-selector knob is jarred or turned slightly. This is generally due to poor contact at the selector switch, in the chassis ground circuit, or in the electrical connections in the head end. It may also result from contact between the insulated portions of the head-end components. To remedy proceed as follows:

1. Clean all contact points with carbon tetrachloride and apply a light film of *Lubriplate* or other non-carbonizing, non-gumming lubricant.
2. Check all contacts to be sure they make firm connection.
3. Be sure that all contact areas between sections of the chassis are well

soldered together, and that all grounding lugs, tube mounting rings, etc. are soldered to the chassis.

4. Be sure that all circuit components (resistors, capacitors, choke coils, etc.) are spaced so they do not contact one another or the chassis; even though the external surface of these components may be an insulating coating.

5. Be sure that the fine-tuning shaft support bearing mounted on the front chassis apron is tight enough to prevent mechanical vibration of the shaft. Caution: If this bearing is too tight, it may cause microphonics.

HOFFMAN All chassis
Increased circuit protection.

Protection of the receivers from shorts or other circuit abnormalities has been accomplished by addition of a fuse in the primary of the power transformer, *T-106*. The fuse is wired in the circuit after the switch and phono a-c outlet, so that only current for the power transformer flows through the fuse. Physical location of the fuse is under the chassis near the power transformer. This location is easily reached through the screened access hole in the cabinet bottom of 10-inch or 12-inch sets, and by sliding the chassis out a few inches on its slide mounting in the 16-inch and 19-inch sets. To prevent turn-on surges from unnecessarily blowing the fuse, a delayed action or *Slo-blo* fuse should be used. The 3AG style, *Slo-blo* fuse is used and has a 2-amp rating for all 10-inch or 12-inch sets and a 3-amp rating for 16-inch and 19-inch sets. These fuses will blow on any sustained plate or

heater-circuit short. The proper type and rating fuses must be used for replacement to insure maximum protection.

The 27- μmf ceramic tubular capacitors, *C-183* and *C-184*, are a potential source of short-circuit trouble. These capacitors are wired from the screen and plate of the 6K6 audio-output tube to ground, and shorting of either capacitor provides a B+ short to ground with subsequent burnout of other components in unfused sets. These capacitors were originally used for suppressing radiation of i-f 3rd harmonic (78.3 mc), but since other measures have reduced this problem, the capacitors serve no further purpose and have been deleted from the set in later production. It is suggested that these capacitors be cut out of any set that is being serviced for any reason.

Lead dress in the high-voltage cage is important to prevent arcing. All leads carrying high voltage should be dressed away from other leads and the grounded cage or cover. One low voltage (+260) d-c lead on the 10-inch or 12-inch sets has been a source of field trouble. This red insulated lead runs from the top of the 500- μmf capacitor, *C-170*, to terminal 4 on the h-v transformer, *T-107*. Its physical location is closely adjacent to the black insulated h-v lead running from terminal 3 of *T-107* to the plate cap of the 1B3. Arcing will occur between these leads if they are not spaced apart. The solder lug atop *C-170* should be rotated so that it points toward the nearest side of the h-v cage. This will hold the red wire away from the black wire, and eliminate arcing.

All of these circuit protection considerations are general in nature and should be applied to any receiver being serviced.

Note: In all sets produced after serial No. A006389, ratings of line fuses have been increased to avoid blowing of fuses during temporary surge currents that may occur when the set is first turned on. The fuses to be used for all 10-inch and 12-inch chassis are the 3-amp, 250-volt, 3AG *Slo-blo* type (part No. 9648), and for all 16-inch and 19-inch chassis, the 5-amp, 250-volt 3AG standard type (part No. 9661). Also, more convenient placement of the line fuse is attained by holding the fuse in an extractor-type fuse post. This fuse post is located on the rear apron of the chassis immediately below the a-c power interlock plug. The fuse can be removed without removing the backboard or disassembling the set.



INDUSTRIAL Chassis IT-1R
Replacement of high-voltage transformer (see Fig. 60).

Due to recurrent failures and breakdown in the 60-cycle high-voltage supply used in the IT-1R (with the 20B-27 h-v transformer), a means has been devised to change over to a fly-back doubler-type supply, such as is used in the IT-3R, 11R, and 13R. This type has proven to be much more dependable, and will greatly reduce, if not eliminate, high-voltage supply failures.

An adapter plate, supporting the necessary components, is supplied. The installation instructions follow:

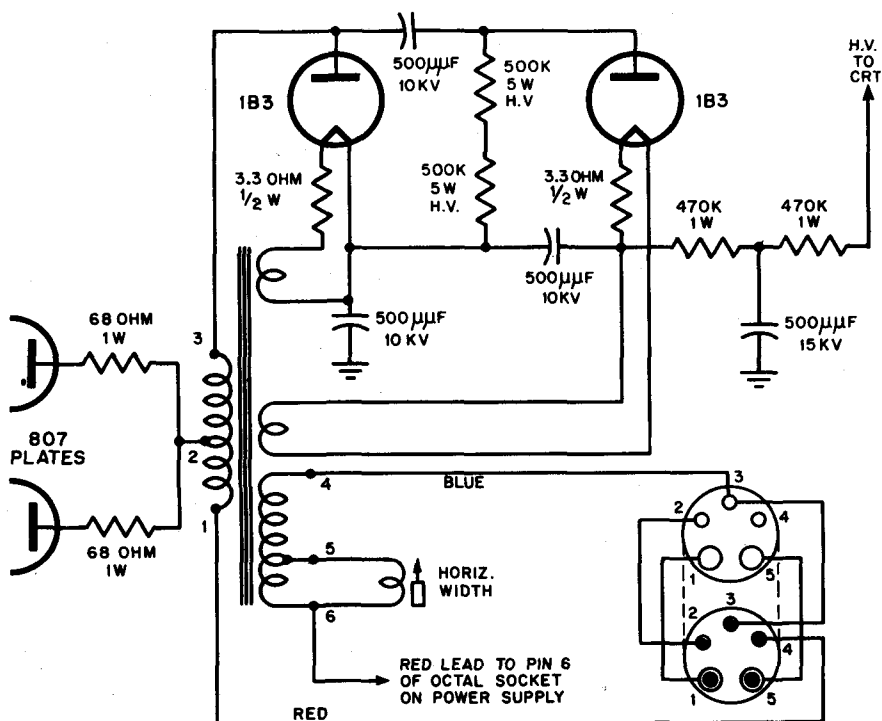

Fig. 60 — Industrial

1. Disconnect all leads from *T-102* (black horizontal-output transformer).

2. Connect lead from junction of *L-105* (horizontal-linearity coil) and *C-138* (.035- μ f capacitor) to pin 4 on *J-102* (yoke socket).

3. Remove relay *K-101*. Jump pins 3 and 4 on relay socket.

4. Install new high-voltage plate, bolting securely in place of old high-voltage transformer. Remove old high-voltage rectifier, filament transformer, and high-voltage bank.

5. Attach red lead from high-voltage plate to pin 6 of octal socket on power supply. Attach plate caps to 807's. Remove yoke plug from yoke

socket, plug in adapter, and plug the yoke plug into adapter. Attach new high-voltage lead to cathode-ray tube.

The relay is no longer required due to the short time constant of the high-voltage filter network. The cathode of the cathode-ray tube should be connected directly to the arm of the brightness-control potentiometer.

The replacement h-v unit is supplied with a connector for a 20-inch tube. When using with a 15-inch set, the connector must be changed.

On some chassis, pin 4 on the yoke-output socket will be found to be grounded. This ground must be removed before the new connection is made to it.

INDUSTRIAL

Chassis IT-1R-2

Increasing sensitivity.

The following change in design is incorporated in later production of IT-1R-2 control units, and is recommended as a field change wherever the present sensitivity is insufficient. An approximate 2:1 increase in gain results from this modification, and a slight improvement in picture quality will be noted.

In the 5th video i-f stage *L-9* (input coil) is replaced by a 6.8-k, 1-watt resistor, and *R-27* (6.8-k resistor connected between output-coupling capacitor and ground) is replaced by *L-9*. Realign the 5th video i-f according to the regular alignment procedure (peak *L-9* at 25 mc).

INDUSTRIAL

Chassis IT-1R-20"

Severe audio distortion or low output.

If either severe distortion or low-sound output is present in the audio amplifier, check for possible miswiring at the audio-output transformer. In some cases it has been found that the B+ lead from *L-401* and *L-402* to the center tap on the primary of *T-402* was miswired to pin 3 of *V-403* or to pin 3 of *V-404*.

INDUSTRIAL

Chassis IT-3R

Increasing audio output.

V-120 (1st audio amplifier) is changed from type 6SN7-GT to type 6SL7-GT. This change is made to provide greater gain and undistorted output. No wiring changes are necessary. This change is recommended for sets in the field only if audio output is insufficient. Later production runs already include this change.

INDUSTRIALChassis IT-11R,
IT-13R**Protection of horizontal-output transformer.**

Due to recurrent internal shorts in type 6BG6-G horizontal sweep output tubes, it has been found necessary to devise a means to protect the horizontal-output transformer from being damaged by excessive current.

A Mazda No. 47, brown bead, 6-8 volt, .150-amp pilot bulb is inserted in the B+ feed to terminal 1 of the horizontal-output transformer, *T-102*, serving as a fuse in case of a shorted 6BG6-G. This change has been made in production, and may readily be made in the field. A special pilot light socket with good insulation to ground is available. The part No. of the socket is 4A-235. This socket clips onto the assembly strap of *T-102*.

INDUSTRIAL

Chassis IT-21R-1-2

Removing intercarrier hum (see Fig. 61).

Fig. 61 — Industrial

Intercarrier hum has been found to be pronounced in many of the sets between serial Nos. 2076 and 2347. It has since become necessary to wire them as shown in the following procedure to prevent this hum. Whenever intercarrier hum is present in sets between serial Nos. 2076 and 2347, the following procedure is recommended:

1. Disconnect *C-131*, 5- $\mu\mu\text{f}$ capacitor, from pin 5 of *V-8* (video detector) to ground and discard.

2. Rewire *L-49*, *R-43*, and *R-45* as shown in the figure.

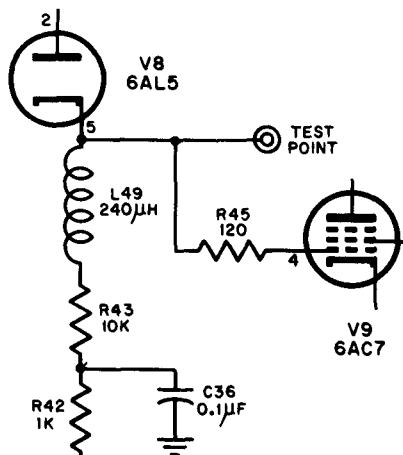
3. After rewiring, connect receiver to antenna and obtain a normal contrast picture. If noticeable hum persists, slight readjustment of the top slug on ratio-detector transformer *T-2* will remove it.

INDUSTRIAL Chassis IT-21R-1-2
Intercarrier hum elimination.

Methods of eliminating intercarrier hum have been set forth here; however, these methods have been found to be ineffective in some receivers. The continuing search for a means of preventing the hum entirely has resulted in the following procedure. This procedure is recommended in any IT-21R-1-2 chassis where noticeable intercarrier hum exists.

Disconnect primary of *T-1* (sound take-off transformer) from circuit. Connect *L-17* (peaking coil) directly to pin 8 of *V-9* (6AC7), video amplifier. Connect one side of *T-1* primary to ground. Connect the other side of *T-1* primary through a 2.2- $\mu\mu\text{f}$ capacitor to the junction of *L-17* and *L-16*. Also, change *C-70*, a 1- μf , 200-volt capacitor across the detector

load to a 10- μf , 200-volt tubular electrolytic connected with the plus side to pin 7 of *V-13*.

After rewiring, connect antenna to receiver and obtain a normal contrast picture. Connect a vacuum-tube voltmeter across *C-70* (detector load) and adjust *T-1* primary and secondary for maximum. Disconnect vacuum-tube voltmeter. Adjust *T-2* secondary (above chassis) until all noticeable hum disappears. This last adjustment should be slight (1/8 to 1/4 turn).

INDUSTRIAL Chassis IT-21R-1-2
Increasing range of horizontal-hold control.

The following procedure is recommended whenever adjustment of the horizontal-hold control seems too critical or narrow:

1. Change *C-75* (between pin 1 of the horizontal-sweep oscillator) to .05 μf at 200 volts.

2. Change *C-130* (coupling capacitor connected to pins 5 and 6 of the phase detector) to .05 μf at 600 volts.

3. Change *R-87* (in plate circuit of sync phase inverter) to 4,700 ohms at 1/2 watt.

4. Disconnect *C-62* (in phase detector circuit) from the junction of *R-79* and *C-130* and connect it to the junction of *R-80* and *C-130*.

INDUSTRIAL Chassis IT-21R
Reduction of hum or buzz in audio.

The following changes are recommended where trouble is experienced with hum or buzz in audio. These changes will eliminate such trouble and will improve the quality of picture and sound.

1. Disconnect primary of *T-1* (sound take-off transformer) from plate circuit of *V-9* (video amplifier).

2. Connect *L-17* (peaking coil) directly to pin 8 of *V-9*.

3. Remove jumper from pin 6 of *V-9* and junction of *R-51*, *R-52*, and *R-53* (screen voltage divider).

4. Connect terminal of *T-1* which previously was connected to pin 8, to pin 6 of *V-9*.

5. Connect terminal of *T-1* which previously connected to *L-17* to junction of *R-51*, *R-52*, and *R-53*.

6. Connect 20,000 ohm-per-volt meter across *C-51* (output of ratio detector), and with meter on 10-volt range, antenna in local plug, and signal tuned in, readjust the top and bottom slugs of *T-1* for maximum voltage across *C-51*.

INDUSTRIAL Chassis IT-21R
Increasing picture size.

To increase vertical size, make *R-96* (in series with vertical-hold control) 1 meg, and make *R-99* (peaking resistor in vertical oscillator) 1,500 ohms. To increase horizontal size, make *R-112* (peaking resistor in horizontal oscillator) 2,700 ohms, and make *R-113* (grid resistor of horizontal-output tube) 270,000 ohms. Also, a higher accelerating voltage can be produced by returning *C-86* (h-v filter) to terminal 4 on *T-5* (horizontal output) instead of ground. These changes have been made in later production runs.

INDUSTRIAL Chassis IT-21R
Centering range of focus control.

R-127 and *R-128* are to be connected in parallel across focus coil

when a Sylvania 12LP4 picture tube is used. These are 1.2-k 1-watt resistors in parallel (600 ohms) to center range of focus. Resistors *R-127* and *R-128* are not required if a DuMont 12QP4 is used.

INDUSTRIAL Chassis IT-21R
Preventing breakdown of h-v filter resistor.

R-120 (high-voltage filter resistor) is changed to 1 meg, 1 watt. Breakdown of the ½-watt resistor formerly used as a filter shows up as a venetian-blind effect or tear out in the horizontal-oscillator circuit due to arcing across open spot in resistor.

INDUSTRIAL Chassis IT-21R
Improving sync stability (see Fig. 62).

The following changes have been made in the *IT-21R* chassis to improve performance and are recommended in the field whenever difficulty has been experienced with vertical- or horizontal-hold stability.

Alter sync-amplifier circuit (½ *V-10*, ½ 12AU7) as shown in part (A) of figure.

1. *R-86* is changed to 47 k.
2. *R-87* is changed to 4.7 k.
3. *R-88* is changed to 4.7 k.
4. *C-64* is now connected to pin 6 of *V-10* instead of junction of *R-86* and *R-87*.

5. Vertical sync integrator circuit is now connected to junction of *R-86* and *R-87* instead of pin 6 of *V-10*.

Alter vertical sync integrator circuit as shown in part (B) of figure.

1. *R-85* is omitted.
2. *C-114*, .01-μf, 300-v mica capacitor is added in parallel with *C-67*.

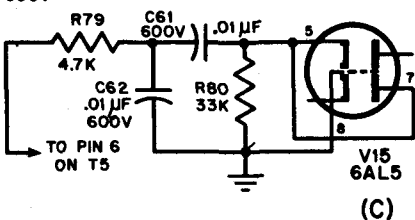
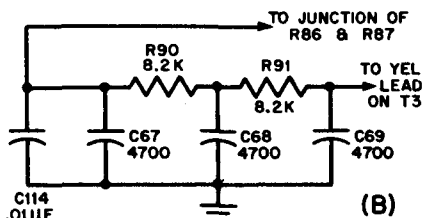
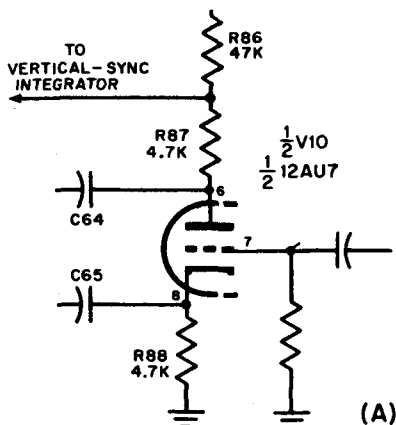

Fig. 62 — Industrial

4. *C-61* is changed to $.01\text{-}\mu\text{f}$, 600-v tubular.

INDUSTRIAL Chassis IT-21R
Improving vertical-size range and vertical linearity.

If difficulty is experienced in obtaining correct vertical size and linearity on early 21R chassis groups, the following changes which will bring them up to present production specifications may be necessary:

1. Change *R-95* (in series with vertical-size control) from 1.5-meg resistor to 1-meg resistor.
2. Change *R-101* (in plate circuit of vertical-output tube) from 6.8-k resistor to 1-k resistor.

INDUSTRIAL Chassis IT-21R
Removing hook at top of picture.

If a bend or hook in the upper vertical wedge is noticed, change *C-75* (connected in grid circuit of horizontal-sweep oscillator) from $.05\ \mu\text{f}$, 200 v to $.1\ \mu\text{f}$, 200 v. Increasing the value of *C-75* increases the filtering in the d-c control voltage to the horizontal oscillator, thereby reducing the hook or bend in the upper vertical wedge. Later production runs have this change.

INDUSTRIAL Chassis IT-21R
Intercarrier hum elimination.

In cases where intercarrier hum cannot be eliminated by other means, *R-144*, a 39-ohm, 1-watt resistor, is to be placed in parallel with *R-123* and *R-129* in the bias circuit of the r-f amplifier, thus putting *R-123*, *R-129*, and *R-144* all in parallel.

3. *C-67* is changed to $4,700\text{-}\mu\text{f}$, 300-v mica.

4. *C-68* is changed to $4,700\text{-}\mu\text{f}$, 300-v mica.

5. *C-69* is changed to $4,700\text{-}\mu\text{f}$, 300-v mica.

Alter horizontal phase detector circuit as shown in part (C) of figure.

1. *C-62* is changed to $.01\text{-}\mu\text{f}$, 600-v tubular.

2. *R-80* is changed to 33 k.

3. *R-79* is changed to 4.7 k.

INDUSTRIAL Chassis IT-35R
Improvement in video response
 (see Fig. 63).

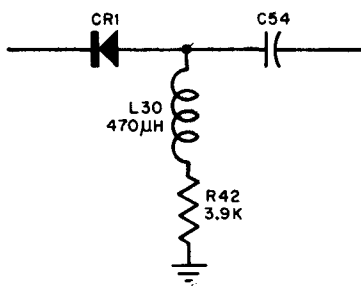

Fig. 63 — Industrial

The following changes improve the video response:

1. Change value of R-42 (video-detector load) from 10-k, 1/2-watt resistor to 3.9-k, 1/2-watt resistor.
2. Add L-30, 470-μh peaking coil, as per drawing.

INDUSTRIAL All chassis
Correction of grid-cathode shorts
 in picture tubes.

Some cathode-ray tubes after a period of use develop a grid-cathode leakage, as evidenced by an apparent lack of d-c restoration and poor or no control of brightness. This is usually caused by a small piece of semiconducting material dropping into the gap between the grid cylinder and the cathode shield. This condition can be cured in many cases by gently tapping the tube neck with a very light rubber-headed tapper, such as an ordinary lead pencil with a rubber grommet forced over the end of it.

In cases where tapping is ineffective, another method has been found to be effective, as follows:

1. Set the brightness control at about midposition.

2. Ground the grid of the cathode-ray tube.

3. Connect an insulated wire to the vertical B+ supply (can be obtained at the vertical-positioning control).

4. Very carefully, momentarily, touch the B+ wire on the arm of the brightness control.

5. Check operation of brightness control.

6. Remove wire from B+, picture tube grid ground, and reset controls.

If one application fails to clear trouble, repeat steps 1 through 5 until brightness control operates properly. The B+ must not be left on the brightness control arm for more than a fraction of a second, or the brightness control may be burned out or the picture tube irreparably damaged.

This procedure has been successfully used in several cases where otherwise the picture tube would have to be replaced.

INDUSTRIAL All chassis
Reduction of a-m interference (see Fig. 64).

A-m interference is characterized by clearly defined straight diagonal or vertical lines or bars across the picture. There are two major possible sources of a-m interference in television receivers located close to an a-m station. The first and most easily corrected is cross-modulation in the input stage, due to overload of this stage by the a-m signal picked up by the antenna or lead-in. The second one is pick-up by the interconnecting cables between the control and picture units.

The first step is to determine the cause of the interference. If the trouble is cross-modulation in the r-f stage, the interference will be a constant percentage of the video signal and will change equally with the picture as the control unit contrast control is operated. If the interference is being picked up on the interconnecting cables, its intensity will not change with change in the control unit contrast control.

In the case of cross-modulation in the input stages, a simple high-pass filter is usually effective. This filter is installed in the antenna lead-in, as close to the control unit as possible, and must be be shielded. A suggested circuit is given in part (A) of the figure.

Where the interference is being picked up by the interconnecting

cables, the cure may be more involved and difficult. The cause of this interference may be from direct pick-up of the interfering a-m signal by the shield of the coax cable, or it may be introduced by a pick-up loop type of circuit, as shown in part (B). In the figure, *C-1* is the primary-to-ground capacitance of the power transformer, and *C-2* is the coil-to-ground capacitance of control relay. Loops are indicated by dotted lines. The alleviation of the interference may require trying several different techniques. Here are a few which should be tried:

1. If the installation is close to an a-m station, keep the control and picture units as close together as possible and the interconnecting cables as short as possible.
2. The simplest method, which can only be used where a relatively strong

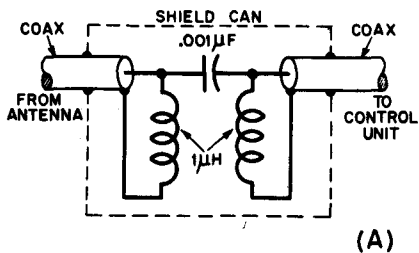

(A)

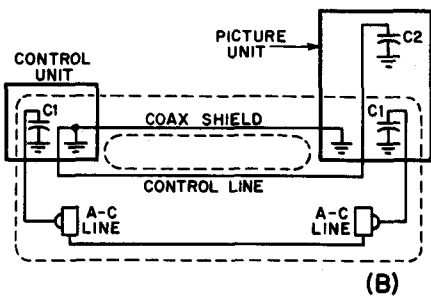

(B)

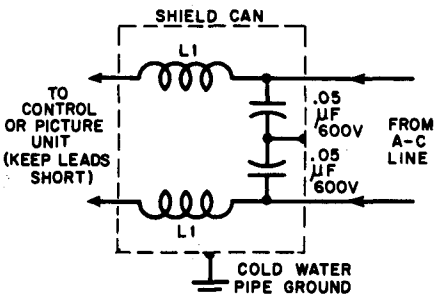

(C)

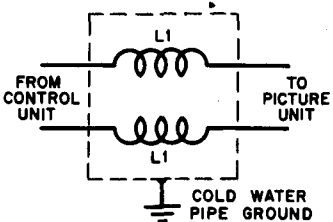

(D)

Fig. 64 - Industrial

television signal is available, is to reduce the contrast control in the picture unit and bring up the control unit contrast control to compensate. This increases the video signal level on the coax cable and increases the signal-to-interference ratio.

3. Bypass the a-c line to ground at either the control unit, the picture unit, or both.

4. Ground the control unit, the picture unit, or both to the nearest cold-water pipe, using heavy wire or flexible braid. Keep ground lead as short as possible.

5. Run a heavy (#00) armored ground wire from control to picture unit, bonding carefully at each unit.

6. Operate both picture and control units from the same a-c outlet, keeping the a-c line as close to the coax as possible.

7. Isolate control and/or picture unit from a-c line. (See part (C) of the fig.). Be sure isolated units are not grounded in any way. The coils *L-1* shown in the figure can be made from 100 turns of No. 14 double cotton covered wire, layer wound on 1/2 inch diameter wood or bakelite forms (about 5 layers, 1 1/2 inch long), varnish or wax impregnated.

8. Isolate relay-control line, as in part (D), inserting isolation in series with control line near control unit. Coils *L-1* are the same construction as in part (C).

9. Use a double-shield coax, such as RG-6/U or RG-42/U between control and picture units in place of RG-59/U. Ground inner shield to both units, and ground the outer shield to either the control or the picture unit.



INTERNATIONAL Chassis F-16 Improvement of sync.

In order to improve the operation of the horizontal and vertical sync on the above chassis, the following circuit modifications may be made:

1. The 6,800-ohm resistor and 390- μmf capacitor on the cathode of the sync-separator tube (pin 6, 6SN7) must be removed from ground (pin 8, 6SN7).

2. Mount a one-lug terminal strip near the 6SN7 socket and wire the 6,800-ohm resistor and 390- μmf capacitor to the open lug.

3. From this lug run a wire (24") to the -20-volt terminal of the bleeder.

4. Insert a .002- μf capacitor from grid of sync amplifier (pin 1, 6SN7) to ground.

These modifications will improve both the horizontal and vertical sync; however, the locking-range padder, width control, and the horizontal speed will require slight readjustment for picture to sync over complete range of horizontal-hold control.

To readjust, proceed as follows:

1. Bring horizontal speed (located on rear of chassis in syncguide) all the way out (counterclockwise).

2. Turn horizontal-locking padder near vertical-linearity pot all the way in.

3. Turn horizontal-hold control to maximum clockwise position. Turn horizontal speed in until 3 to 5 diagonal lines appear on the screen. Note: If picture locks prematurely, switch

channel selector to kill signal and return to channel under adjustment. Then continue tuning horizontal speed until 3 to 5 lines appear.

4. Turn hold control to maximum counterclockwise position. Kill signal by switching channel selector off channel and back. Bring out horizontal locking range until 7 lines appear on the screen.

5. Turn hold to maximum clockwise position. Set will break out of sync. Readjust syncroguide until 3 to 5 lines appear on the screen.

6. Now lock-in should occur over complete range of control.

7. Leave horizontal hold in center for optimum results.

8. Readjust width control (padder located nearest height pot) if necessary.



JACKSON Chassis 114G, 116G, 117G, 120G
Increasing sensitivity for fringe-area operation.

The following hints may be helpful for improving sensitivity in fringe areas. These hints should be followed in the sequence given. The balance of the procedure can be omitted if satisfactory results are obtained at any point in the procedure.

1. Make sure that the proper antenna is used and correctly installed.
2. Check the rectifier tube (5U4G) by substitution since the voltage output of some tubes may be slightly higher. An increase in B-voltage will increase sensitivity.
3. Check the video-amplifier tube (6AC7) by substitution. Increased

contrast is sometimes obtained with tube replacement.

4. Check the power-line voltage. If the voltage is known to vary greatly, it is recommended that the set be operated from a constant-voltage transformer with a power rating of at least 300 watts.

5. Carefully realign the receiver following the instructions given in the service notes. Checking tubes (by substitution) in the r-f amplifier, oscillator-mixer, i-f stages, and video detector while aligning will often give considerable increase in gain. The increase in gain may be observed by an increase in amplitude on the response curve. Realignment of the particular stage should always be made after each tube replacement in order to realize the maximum gain possible.

JACKSON Chassis 114G, 116G, 117G, 120G
Improving vertical sync stability in fringe areas (see Fig. 65).

To improve the vertical-sync stability in weak-signal areas, proceed as follows:

1. Remove vertical-integrator plate.
2. Make up vertical integrating circuit as shown in the the figure.

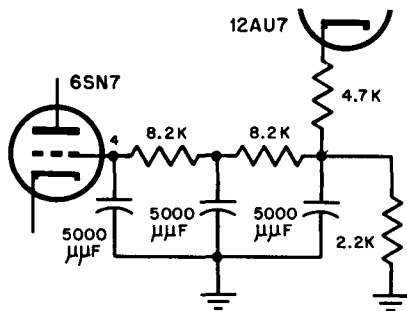

Fig. 65 — Jackson

JACKSON Chassis 114G,
116G, 117G, 120G
Intermittent picture and sound.

This trouble is most commonly due to an intermittent tube, loose tube socket contacts, dirty or loose coil contacts, loose or cold (rosin) soldered joints, or loose or vibrating parts in the underside of the tuner chassis.

Loose tube socket contacts may sometimes be tightened by compressing contacts with an ice pick or a large needle. Defective tube socket contacts can sometimes be replaced individually.

Loose or intermittent connections can be found by tapping components or rotating the channel selector and watching the pattern on an oscilloscope. A visual inspection or a continuity check will also be helpful.

Apply a hot soldering iron to soldered joints which appear doubtful. Caution: Do not change lead lengths or move components other than to slightly separate parts or leads which have caused trouble by contact with the chassis or other parts.

JACKSON Chassis 114G,
116G, 117G, 120G
**Sound bars due to tuner
microphonics.**

Microphonics in the tv tuner will generally produce sound bars in the

picture or a ringing sound as the volume is turned up or as the cabinet is tapped lightly.

Check for microphonic oscillator-mixer tube, V-2 (6J6). It is recommended that several tubes be tried, in order to select a tube which will be least microphonic and at the same time, causes a minimum of oscillator frequency shift, as noted with rotation of tuning control. In some cases, replacement of the oscillator-mixer tube, may necessitate readjustment of trimmer capacitor C-5 (over-all oscillator adjustment).

Microphonics can also be due to vibration of loose wires or loose components. In some instances, the ceramic stator plate (tuning stator) has been a source of microphonics since the rivets which fasten this part to the tuner chassis may be loose. This can be remedied by soldering the plate-mounting bracket to the tuner chassis. To solder the plate-mounting bracket to the tuner chassis, remove the grounded tuning stator plate, and move the tuner shaft forward.

Also, check for any mechanical rub such as loose screws which hold the tuner sub-chassis to the main chassis, loose solder connection from tube shield base to chassis, or extremely dry tuner shaft.



INDEX

	Page		Page
4.5-mc beats, <i>see</i> : Interference; Picture, sound		Beam current, <i>see</i> Picture-tube beam current	
60-cycle hum, <i>see</i> : Buzz; Hum		Beam modulation in horizontal output tube, <i>Hoffman</i> , 170, 171, 173, 175	90
A		Blanking, <i>see</i> Retrace blanking	
Adapter plug, <i>see</i> Plug		Blooming, reducing, <i>Emerson</i> , 120134-B	12
Adjacent channel trap, <i>see</i> Trap		Brightness, <i>see</i> Picture Brightness	
Agc, <i>see</i> : Fringe area, agc; Sensitivity, improvement		Brightness control, increasing range of, <i>Firestone</i> , 13-G-51, -52	23-24
A-m rejection, <i>see</i> : Ratio detector; Transformer;		<i>General Electric</i> , 17C110, -111	42
Amplifier, <i>see</i> I-f amplifier		810	51
Aquadag, <i>see</i> Picture tube coating		<i>Hoffman</i> , 170 through 176	88-89
Arcing, <i>Freed</i> , all chassis	30	linearity changes with, <i>Freed</i> , 1620B	28
at h-v anode of picture tube, <i>Firestone</i> , 13-G-49, -50, -53, -54, -59, -79	23	picture distortion, <i>General Electric</i> , 801, 802, 803	47
at h-v rectifier socket, <i>Hoffman</i> , 140, 142, 146	65	<i>see also</i> Picture contrast	
hiss, <i>Freed</i> , 1620 series, 1916	27	Buzz, <i>Hoffman</i> , 159, 160	75-76
in h-v cage, <i>Fada</i> , S-1055, S-1055X, S1060	20-21	audio, reduction, <i>General Electric</i> , 12C107, -108, -109	109
<i>Freed</i> , 1610	26	12T3, -4, -7	34
<i>Gamble-Skogmo</i> , 05TV2-43-8950A, -9010A	31	<i>Hoffman</i> , 143	69-70
internal, <i>Freed</i> , 1610, 1620 series, 1916	26	<i>Industrial</i> , IT-21R	103-104
near picture tube neck, <i>Hoffman</i> , chassis with 16-inch metal picture tubes	98	due to excessive signal, <i>General Electric</i> , 810, 811, 814	49
Audio, clicks, <i>General Electric</i> , 810, 811, 814, 830, 835	49	intercarrier, reduction, <i>Emerson</i> , 120123-B	2-4
compensation, <i>General Electric</i> , 840	52	<i>Firestone</i> , 13-G-44 through -48, 13-G-51, -52	21
distortion, <i>Industrial</i> , IT-1R-20"	102	modulation at high channels, <i>General Electric</i> , 802, 803	47
high-frequency response, <i>General Electric</i> , 820	51-52	sync, 60-cycle, <i>Freed</i> , 1620C, 1900	29
howl, <i>General Electric</i> , 810, 814	50-51	sync, in sound, <i>Freed</i> , 1610, 1620 series, 1916	25
i.f., <i>see</i> : I-f, audio; Transformer output, increasing, <i>Industrial</i> , IT-3R	102	vertical, <i>Freed</i> , 1610, 1620 series, 1916	26
		1610	26
		<i>see also</i> Hum	
B		C	
Bandpass, <i>see</i> I-f bandpass		Capacitor, breakdown, <i>General Electric</i> , 14C102, -103, 14T2, -3, 16C103, -104, -113, -114, 16K1, -2, 16T3, -4, -5, -6	36
Barkhausen oscillation, <i>see</i> Oscillation, Barkhausen			

	Page		Page
high leakage of C-311, <i>General Electric</i> , 14C102, -103, 14T2, -3, 16C103, -104, -113, -114, 16K1, -2, 16T3, -4, -5, -6	36		
see also Leakage current			
Centering, see Focus control			
Christmas-tree effect, see I-f regeneration			
Contrast, see: Brightness control; Picture contrast			
Corona, see arcing			
Coronado, see Gamble-Skogmo			
Crystal-diode replacement, see Video-detector			
E			
Emerson	1-19		
F			
Fada	19-21		
Fine-tuning control, <i>Freed</i> , 1620B	28		
Firestone	21-24		
F-m interference, see Tuner,			
Focus, control range, centering, <i>Emerson</i> , 120129-B, -D,	9-10		
<i>Freed</i> , 1610, 1620 series, 1916	25		
1610	26		
<i>Industrial</i> , IT-21R	104		
improvement, <i>Freed</i> , 1900	29		
<i>Hoffman</i> , 159, 160	75		
170 through 176	85		
increasing, <i>Hoffman</i> , 142, 146, 149, 150, 154	68		
Foldover, horizontal, <i>Emerson</i> , 120118-B	1		
120142-B, 120143-B, 120148-B	13-14		
vertical, <i>Emerson</i> , 120129-B, -D, 120140-B, -G, -H, 120144-B, -G, -H	8		
<i>Hallicrafters</i> , 1002 through 1007, 1015 through 1019	56		
see also Linearity, vertical			
<i>Freed</i>	25-30		
Fringe-area, age modifications for, <i>Emerson</i> , 120129-B, -D	10-11		
120129-B, -G	9		
120142-B, 120143-B, -H	14-15		
<i>Gamble-Skogmo</i> , 05TV2-43-9010B, 15TV2-43-9012A, -9013A	31-32		
audio quality, improving, <i>Emerson</i> , 120134-B	12-13		
gain, increasing, <i>Fada</i> , R-1025, R-1050	19		
jitter, preventing, <i>Emerson</i> , 120153-B	17-18		
120158-B	18-19		
picture and sound tracking, <i>Emerson</i> , 120134-B, -G	12		
sensitivity, improvement, <i>Jackson</i> , 114G, 116G, 117G, 120G	109		
see also Sensitivity, snow, reducing, <i>Hallicrafters</i> , T-60, T-64, T-67, T-68, 509	54		
All 10-inch picture tube models	56		
sync stability, <i>Emerson</i> , 120129-B, 120134-B, -G, 120135-B	8-9		
120129-B, -D, 120135-B, -G, -H, 120140-B, -G, -H, 120141-B, -G, -H	7		
120129-B, -D, 120140-B, -G, -H, 120144-B, -G, -H	7-8		
<i>Hoffman</i> , 170 through 176, 180, 183 through 187	83-84		
vertical, <i>Emerson</i> , 120142-B, 120143-B, 120148-B	13		
<i>Jackson</i> , 114G, 116G, 117G, 120G	109		
see also Sync stability			
video i-f peaking, <i>Hoffman</i> , 140, 142, 143, 146, 147	65		
Fuse, addition, <i>Hoffman</i> , all chassis	99-100		
life, increasing, <i>Hoffman</i> , 187, 187B	93		
G			
<i>Gamble-Skogmo</i>	30-33		
<i>General Electric</i>	33-54		
H			
<i>Hallicrafters</i>	54-56		
Head end, see Noise in head end			
Herringbone pattern, see: Interference on Channel 2, 5, 11, 13; see also Trap adjustment, high channel			
High-voltage, arcing, see Arcing, failure, <i>Firestone</i> , 13-C-46, -47, -48	22		
transformer, see Transformer			

	Page
Hoffman	56-100
Hook, <i>see</i> Picture, vertical lines bent at top	
Horizontal bars, <i>see</i> Trap adjustment, high channel	
Horizontal-drive control, <i>General Electric</i> , 16C110, -11, -15	
16T1, -2	40
<i>see also</i> , Picture, vertical lines at left, dark	
Horizontal-hold control, <i>General Electric</i> , 10C101, -102, 10T1, -4, -5, -6, 12C107, -108, -109, 12K1, 12T3, -4, -7	33
<i>Hoffman</i> , 156, 157, 164	72
<i>Industrial</i> , IT-21R-1-2	103
Horizontal linearity, <i>see</i> Linearity, horizontal	
Horizontal multivibrator, <i>Firestone</i> , 13-G-51, -52	24
Horizontal oscillator, drift, <i>General Electric</i> , 810, 811	50
<i>Hallcrafters</i> , 1002 through 1007, 1015 through 1019	55
improved starting at low-line voltage, <i>Emerson</i> , 120142-B	16
<i>see also</i> Sync, horizontal	
Horizontal-output, transformer, <i>see</i> Transformer,	
Horizontal-peaking control, centering range, <i>General Electric</i> , 19C101	45
Horizontal pull-in range, <i>General Electric</i> , 12C107, -108, -109, 12T3, -4, -7	34
Horizontal stability, <i>see</i> Stability, horizontal	
Horizontal-sweep, failure, <i>General Electric</i> , 901, 910	52
increasing, <i>General Electric</i> , 12C107, -108, -109, 12T3, -4, -7	34
pick-up in video amplifier, <i>Emerson</i> , 120134-B, -C, 130135-B	11-12
reduced, <i>Freed</i> , 1620B	27-28
width, insufficient, <i>General Electric</i> , 805, 806, 807, 809, 817, 818, 821	48
Howl, <i>see</i> Audio howl; Microphonic	
Hum, 60-cycle at high volume, <i>Freed</i> , 1610, 1620 series, 1916	25
at low volume, <i>Freed</i> , 1610, 1620 series, 1916	25
intercarrier, <i>Industrial</i> , IT-21R-1-2	102-103
IT-21R	105

	Page
modulation, <i>General Electric</i> , 17C113, -115, -117, -120, 17T7	43
nontuneable, <i>see</i> Microphonic residual, <i>General Electric</i> , 16K1, -2	40-41
tuneable, <i>Freed</i> , 1610, 1620 series, 1916	26
<i>Hoffman</i> , Chassis with turret tuners RF-3, RF-4, RF-5, RF-6	96
<i>see also</i> Buzz	
I	
I-f amplifier, <i>General Electric</i> , 17C113, -115, -117, -120, 17T7	45
overloading, <i>Hoffman</i> , all chassis with signal-keyed age	98-99
I-f audio selectivity, <i>General Electric</i> , 810, 814	50
<i>Hoffman</i> , 170, 171, 173, 175	91
I-f bandpass, improving, <i>Emerson</i> , 120095-B, 120123-B, 120133-B, 120138-B	1
<i>Hoffman</i> , 170 through 176	86
I-f bandwidth, realignment, <i>see</i> Fringe-area, gain	
I-f regeneration, <i>Emerson</i> , 120134-B	12
<i>General Electric</i> , 811, 814, 820, 830, 835	51
<i>Hoffman</i> , 159, 160	77-78, 80-81
I-f transformer, <i>see</i> Transformer	
I-f tweet, <i>General Electric</i> , 17C110, -111	42
<i>Industrial</i>	100-108
Instability, high channel, <i>General Electric</i> , models with "B-version" head-end unit	52-53
Intercarrier buzz, <i>see</i> Buzz	
Interference, 4.5-mc beats, <i>Hoffman</i> , 170 through 176	85-86
<i>see also</i> Picture, sound bars a.m., <i>Industrial</i> , all chassis	106-108
high channel, <i>General Electric</i> , 810, 811, 814, 820, 830, 835, 840	48
on channel 2, <i>Hoffman</i> , 159, 160, 170 through 176, 180, 183 through 187	74-75

	Page
on channel 5, <i>Hoffman</i> , 140, 142, 143, 146, 147	59-60
170 through 176, 180, 183 through 187	81-82
on channel 6, <i>General Electric</i> , 17C113, -115, -117, -120, 17T7	43
on channel 11, <i>Hoffman</i> , 140, 142, 143, 146, 147	63
on channel 13, <i>Hoffman</i> , 140, 142, 143, 146, 147	62-63
to a-m broadcast sets, <i>Emerson</i> , 120124	4
Interlace, improving, <i>Hallicrafters</i> , 1002 through 1007, 1015 through 1019	55
<i>Hoffman</i> , 143, 147, 151	68-69
vertical, <i>Emerson</i> , 120129-B, -C	9
International	108-109

J

Jackson	109-110
Jitter, <i>see</i> Fringe area; Sync	

L

Lead-dress precautions, <i>Hoffman</i> , all 10-, 12-, 16-, and 19-inch chassis	96-98
Leakage current, reduction, <i>General Electric</i> , 17C113, -115, -117, -120, 17T1	44
Linearity, horizontal, <i>Gamble-Skogmo</i> , 94TV1-43-8940A	33
<i>General Electric</i> , 17C113, -115, -117, -120, 17T7	44-45
vertical, <i>General Electric</i> , 17C110, -111	42
<i>see also</i> Foldover, vertical	
Low-frequency response, <i>General Electric</i> , 12T7, 16C110, -111, -115, 16T1, -2	35

M

Microphonic, <i>Hoffman</i> , 135	56
tuner, <i>Jackson</i> , 114G, 116G, 117G, 120G	110

Modulation, <i>see</i> Station modulation variations	
Motorboating, <i>see</i> Oscillations in sound channel	
Multivibrator, <i>see</i> Horizontal	

N

Neck shadow, removing, <i>Emerson</i> , 120123-B, 120131-B, 120133-B, 120138-B	2
120127-B, 120128-B	5
<i>Freed</i> , chassis with metal picture tubes	29
<i>Hoffman</i> , 140, 142, 143, 146, 147	60-61
Noise, <i>see</i> Tube, noise level	
Noise condition, adverse, <i>see</i> Sync, picture	
Noise in head end, <i>Hoffman</i> , models with RF-1 head end	94
RF-2 head end	94-95
RF-3 head end	95-96
all chassis	99
Noise pulses, <i>see</i> Sync	
Noise reduction, <i>see</i> Fringe-area, snow reducing	

O

Optical box, discoloration of mirror, <i>Emerson</i> , 120084-B	1
Oscillation, <i>Emerson</i> , 120153-B	16-17
audio, high pitch, <i>Hoffman</i> , 140, 142, 143, 146, 147	62
Barkhausen, <i>Emerson</i> , 120127-B, 120128-B	67
<i>General Electric</i> , 16C110, -111, -115, 16T1, -2	40
channel 6, <i>General Electric</i> , 14C102, -103, 14T2, -3, 16C113, -116, 16K1, -2, 16T3, -4	38
high frequency, transient, <i>see</i> Picture, vertical lines at left, dark	
in sound channel, <i>Hoffman</i> , 146,	70-71
of horizontal-sweep output, <i>see</i> Horizontal-hold control	
parasitic, <i>Gamble-Skogmo</i> , 05TV1-43-8945A, -9005A, -9006A	30

Oscillator, *see* Horizontal oscillator
 Overloading, *see* I-f amplifier

P

Parasitic oscillation,
see Oscillations, parasitic
 Picture, blanked out partially,
see: Capacitors, high leakage
 blooming; Blooming
 brightness,
Hallicrafters,
 T-54, 505 54
see also Brightness control
 carrier beats on channel 5
Emerson, 120127-B,
 120128-B, 120141-B 4-5
 contrast and sharpness,
Emerson, 120118-B 1-2
Hoffman, 170 through 176 88
see also Brightness control
 curl at top,
General Electric, 14C102,
 -103, 14T2, -3, 16C103, -104,
 -113, -114, 16T3, -4, -5, -6 37
 deflection,
Hoffman, 170 through 176 89-90
 diagonal lines, *see*: Interference,
 a.m. distortion; Brightness control
 height, improving,
Industrial, IT-21R 105
 horizontal white lines in,
Hoffman, 135 56
 horizontal white lines, top,
Hallicrafters, T-64, 509 54
 interference, *see* Interference
 intermittent,
Freed, 1610 27
Jackson, 114G,
 116G, 117G, 120G 110
 jitter, *see* Fringe area; Sync
 pulling,
Freed, 1610 26
 quality, improving, *see*
 Tube, noise level
 ringing, *see* Blooming
 roll, *see* Sync, vertical
 shadow at top,
Hoffman, 156, 157, 164 72
 smear, *see* Smear
 sound bars in,
Freed, 1610 27
 1620B, C 27-28
Hoffman, 135 57-59
see also Microphonic
 tracking, *see* Fringe area,
 picture and sound tracking
 trailing shades, *see* Smear

vertical lines at left,
General Electric, 140C102,
 -103, 14T2, -3, 16C113,
 -116, 16T3, -4 39
 vertical lines at left, dark,
Hoffman, 135 59
 vertical lines, bent at top,
Freed, 1620A, B, C 27
Hoffman, 156, 157, 164 73
 159, 160 76-77
Industrial, IT-21R 105
 vertical lines, white,
General Electric, 19C101 45
Hoffman, 170, 171, 173, 175 90
 143, 151, 152 69
 vertical lines, white, right,
Hoffman, 135 56
 width excessive,
Emerson, 120129-B, -D 10
 width insufficient,
Hoffman, 135 56
 156, 157, 164 72-73
Industrial, IT-21R 104
 wiggle at left side, top,
General Electric, 814 51
 Picture tube, beam current,
Firestone, 13-G-46 47
 coating, grounding,
Firestone, models using
 Hytron picture tubes 24
Hoffman, 156, 157,
 159, 160, 164 71-72
 grid-cathode shorts,
Industrial, all chassis 106
 heater-cathode breakdown,
Hoffman, 159, 160 80
 170, 171, 173, 175 90-91
 magnetized,
Freed, chassis with
 metal picture tubes 30
 removal,
General Electric, all models
 using series filaments 53
 shadow, right side,
Hoffman, 170 through 176 87-88
see also Neck shadow
 Plug, adapter,
General Electric,
 12K1, 818 34-35
 power,
Hoffman, 146 70
 Power-supply loading,
Emerson, 120129-B 11
 Power transformer, *see* Transformer

R

Ratio detector, a-m rejection,
Hoffman, 140, 142,
 143, 146, 147 63-64

	Page
Regeneration, <i>see</i> I-f	
Resistor, breakdown of R-120, <i>Industrial</i> , IT-21R	104
Resonance, component, <i>Firestone</i> , 13-G-48	22-23
Retrace blanking, <i>Hallicrafters</i> , 1002 through 1007, 1015 through 1019	55
Retrace lines, removing, <i>Fada</i> , S-1055, S6T65, S7C20, S7C30, S7T65, S20C10, S20T20	19-20
<i>General Electric</i> , 810, 811, 814	49-50
Ringling, sweep, <i>see</i> Sweep ringing	
Rumble, <i>see</i> Audio compensation	

S

Sensitivity, audio, <i>General Electric</i> , 19C101	45
improvement, <i>Freed</i> , 1620A, B	27
1620C, 1900, 1916	28
<i>Hallicrafters</i> , T-54, 505	54
<i>Industrial</i> , IT-1R-2	102
<i>see also</i> Fringe area; Sound sensitivity	
Smear, <i>Hoffman</i> , 170, 171, 173, 175	91-92
170 through 176	88
187, 187B, 187C	92-93
on channel 4, <i>General Electric</i> , 14C102, -103, 14T2, -3, 16C113, -116, 16K1, -2, 16T3, -4	38
Snow, <i>see</i> Fringe area	
Sound, alignment, <i>Emerson</i> , 120133-B	11
bars in picture, <i>see</i> Picture, sound bars in	
buzz in, <i>see</i> Buzz	
discriminator transformer, <i>see</i> A-m rejection	
distortion, <i>see</i> Ratio detector	
sensitivity, improving, <i>Hallicrafters</i> , 1002 through 1007, 1015 through 1019	55-56
tracking, <i>see</i> Fringe area	
picture and sound	
trap, addition of, <i>Emerson</i> , 120153-B	17
tuning, <i>see</i> Audio i-f selectivity	
Stability, horizontal, <i>Firestone</i> , 13-G-49, -50, -53, -54, -55, -59, -79	23
<i>Gamble-Skogmo</i> , 05TV2-43-8950A, -9010A	31
<i>Hallicrafters</i> , T-60, T-64, T-67, T-68, 509	54
<i>see also</i> Sync	

vertical, <i>Firestone</i> , 13-G-49, -50, -53, -54, -55, -59, -79	23
<i>General Electric</i> , 16C110, -111, -115, 16T1, -2	39
<i>see also</i> Sync,	
Station modulation, variation, reducing effects of, <i>Emerson</i> , 120138-B	13
Strong signal areas, <i>see</i> : Audio clicks; I-f amplifier; Sync; Traps	
Sweep, <i>see</i> Horizontal sweep	
Sweep generator failure, <i>see</i> Tube	
Sweep ringing, reducing, <i>Firestone</i> , 13-G-46, -47, -48	22
Sweep width, <i>see</i> Horizontal sweep width	
Sync, buzz, <i>see</i> Buzz	
circuit improvement, <i>General Electric</i> , 17C110, -111	41
fringe area, <i>see</i> Fringe area	
horizontal, <i>Emerson</i> , 120118-B	2
<i>Freed</i> , 1610, 1620 series, 1916	25
1620C, 1900	28-29
1916	29
<i>General Electric</i> , 800 series, 805, 806, 807, 817, 821	46
<i>Hoffman</i> , 159, 160	77
<i>see also</i> Sync, picture	
improving under adverse noise, <i>Emerson</i> , 120153-B, 120154-B	16
<i>Fada</i> , S-1055, S6T65, S7C20, S7C30, S7T65, S20C10, S20T20	20
internal radiation effects on, <i>Emerson</i> , 120124	4
stability <i>Firestone</i> , 13-G-44 through -48	21
<i>Hoffman</i> , 153, 156, 157, 164	71
<i>Industrial</i> , IT-21R	104-105
<i>International</i> , F-16	108-109
vertical, <i>Emerson</i> , 120127-B, 120128-B	5
<i>General Electric</i> , 14C102, -103, 14T2, -3, 16C103, -104, -113, -116, 16T3, -4, -5, -6, 17C101, -102	36
<i>Hoffman</i> , 140, 142, 146	66-68
170 through 176, 180, 183 through 187	83
183, 187, 187B, 187C	92
Mark IV chassis	94
<i>see also</i> Vertical-hold	
Tearing, horizontal, <i>Emerson</i> , 120153-B	17

	Page
Test pattern, wiggle, vertical, <i>Freed</i> , 1620B	28
Transformer, audio i.f., <i>General Electric</i> , 10C101, -102, 10T1, -4, -5, -6, 12C107, -108, -109, 12K1, 12T3, -4, -7	33
high-voltage, replacement, <i>Industrial</i> , IT-1R	100-101
horizontal output, <i>General Electric</i> , 801, 802, 803, 805, 806, 807, 809, 810, 811, 814, 820, 830, 835, 840	46-47
<i>Industrial</i> , IT-11R, -13R	102
i-f, mounting modifications, <i>Hoffman</i> , 170 through 176, 180	84
power, protection, <i>Emerson</i> , 120142-B, 140143-B, -H	15-16
sound discriminator, <i>Firestone</i> , 13-G-51, -52	24
Trap, adjacent channel, <i>Hoffman</i> , 159, 160	79
187, 187B	93-94
adjustment, high channel, <i>General Electric</i> , 14C series, 14T series, 16C series, 16K series, 16T series, 17C series, 17T series	35-36
transmission line, <i>General Electric</i> , all models	53-54
<i>see also</i> , Sound trap,	
Trapazoiding effect, <i>see</i> Yoke, failure	
Tube, failures, reducing 1X2, <i>Gamble-Skogmo</i> , 05TV2-43-9010B, 15TV2-43-9012A, -9013A	31
<i>General Electric</i> , 14C102, -103, 14T2, -3, 16C110, -111, -113, -115, -116, 16T1, -2, -3, -4	37-38
<i>Hoffman</i> , 159, 160	79-80
horizontal output, current, <i>General Electric</i> , 14C102, -103, 14T2, -3, 16C103, -104, -113, -114, 16T3, -4, -5, -6	37
noise level, decreasing, <i>Firestone</i> , 13-G-44 through 48	21-22
plate dissipation, reducing, <i>General Electric</i> , 17C110, -111	41
<i>see also</i> Picture tube,	
Tuner, f-m interference, <i>General Electric</i> , 17C110, -111	41-42
noisy or intermittent, <i>Freed</i> , 1620B	28
Tweet, <i>see</i> I-f tweet; Interference	

V

	Page
Vertical-hold control, centering, <i>Emerson</i> , 120127-B, 120128-B	5
120129-B, -D, 120140-B, -G, -H, 120144-B	8
<i>Firestone</i> , 13-G-51, -52	24
<i>Freed</i> , 1610, 1620 series, 1916	25
<i>General Electric</i> , 10T1, -4, -5, -6	34
increasing range, <i>Halicrafters</i> , 1002 through 1007, 1015 through 1019	55
Vertical linearity, <i>see</i> Linearity, <i>Hoffman</i> , 143, 147	69
Vertical size control, range, <i>General Electric</i> , 901, 910	52
excessive, <i>Emerson</i> , 120142-B, 120143-B, -H	15
120129-B, -D, 120144-B, -C, -H	9
<i>Hoffman</i> , 159, 160	78
Vertical stability, <i>see</i> Stability, vertical,	
Vertical sweep, collapse, <i>Halicrafters</i> , T-64, 509	55
Vertical sync, <i>see</i> Sync	
Video detector, crystal diode replacement, <i>General Electric</i> , 17C113, -115, -117, -120, 17T7	43-44
Video response, improving, <i>Industrial</i> , IT-35R	106
Volume control, <i>see</i> Audio clicks, <i>Hoffman</i> , all chassis	99

W

Weak signal, <i>see</i> Fringe area	
Width, <i>see</i> Picture width	
<i>Emerson</i> , 120127-B	7
reduction, <i>see</i> Yoke, failure	
Wiggle, <i>see</i> Picture wiggle	

Y

Yoke, failure, <i>Gamble-Skogmo</i> , 05TV1-43-9014A....	31
installation, improving, <i>General Electric</i> , 17C110, -111	42-43
plug, increased insulation, <i>General Electric</i> , 19C101	45
ringing, <i>General Electric</i> , 16C110, -111, -115, 16T1, -2	40
<i>see also</i> , Neck shadow	

These **RIDER** books make **TV servicing EASY!**

TV TROUBLESHOOTING AND REPAIR GUIDE BOOK, VOL. 1

by Robert G. Middleton

Know how to recognize TV receiver troubles and cure them. This book shows you how through the use of pictures taken directly from TV receiver picture tubes and scopes. Valuable troubleshooting charts are also given. Not a theory book — but a practical troubleshooting and repair guide guaranteed to save hours of time-consuming labor. 204 pages, 8½ x 11", illus. *Only \$3.90*

RECEIVING TUBE SUBSTITUTION GUIDE BOOK

by H. A. Middleton

Answers all tube problems by listing 2,500 radio-television tube substitutions in numerical sequence with accompanying wiring instructions, original and substitute tube socket illustrations. It helps you turn out jobs that would otherwise remain on the shelf because of lack of proper tubes. 224 pages, 8½ x 11". *Only \$3.00.*

FIRST SUPPLEMENT, RECEIVING TUBE SUBSTITUTION GUIDE BOOK

by H. A. Middleton

750 completely new and different radio-TV tube substitutions not listed in the first edition. Special section on substituting tubes in television receivers. 48 pages, 8½ x 11". *Only 99¢.*

To be Published Soon

TV MANUFACTURERS' RECEIVER TROUBLE CURES, VOL. 3

The third volume in this series of practical books that gives exact directions for correcting TV receiver performance "bugs." Each remedy is developed by the receiver's own manufacturer. Covers many prominent brands not included in Volumes 1 and 2. *One service job will more than pay the cost of the book.* Over 100 pages, 5¼ x 8¼", illustrated. *Only \$1.80.*

TV SWEEP ALIGNMENT TECHNIQUES

by Art Liebscher

Never before has there been such a book on this important subject. Exclusive information and material not generally available to service technicians is included. The new *Supermark* method is introduced. The author is a famous test equipment specialist. Over 100 pages, 5¼ x 8¼", illus. *Only \$2.10*

JOHN F. RIDER PUBLISHER, INC., 480 CANAL ST., N. Y. 13, N. Y.

ADV Plans, LLC

Copyright Notice:

The entire contents of this CD/DVD are copyright 2014 by ADV Plans, LLC. All Rights Reserved.

Reproduction or distribution of this disk, either free or for a fee is strictly prohibited. We actively monitor and remove listings on eBay thru Vero.

You are free to copy or use individual images in your own projects, magazines, brochures or other school projects.

Only the sellers listed here are authorized distributors of this collection:
www.theclassicarchives.com/authorizedsuppliers

Please view our other products at
www.theclassicarchives.com,
or our ebay stores:

[TheClassicArchives](#)
[ADVPlans](#)
[SuperShedPlans](#)

